



# Delta Media Server

## DeltaServer and DeltaGUI 2.7

User Guide



## DeltaServer and DeltaGUI 2.7 : User Guide

### Trademark Information

The 7thsense logo, and various hardware and software product names are trademarks of 7thSense Design Ltd. Product or company names that may be mentioned in 7thSense publications are tradenames or trademarks of their respective owners, and such trademarks may also be registered in their respective countries. Windows is a registered trademark of Microsoft Corporation in the United States and other countries.

### Copyright Information

All Rights Reserved. This document is copyrighted © by 7thSense Design Ltd and shall not be reproduced or copied without express written authorisation from 7thSense Design Ltd.

The information in this document is subject to change without notice. 7thSense Design Ltd assumes no responsibility for errors, and/or omissions contained in this information.

Printed: March 2023

This edition is for software version 2.7.8  
Document ref.: M384-4

E: [info@7thsense.one](mailto:info@7thsense.one)  
W: 7thsense.one

7thSense Design Ltd  
2 The Courtyard, Shoreham Road  
Upper Beeding  
Steyning  
West Sussex  
BN44 3TN  
UK

T: +44 (0) 1903 812299

7thSense Design LLC  
4207 Vineland Rd  
Suite M1  
Orlando, FL 32811  
USA

T: +1 407 505 5200

<b>Delta User Guide</b>	<b>9</b>
Overview: Delta System Architecture	12
Multi Rack Architecture	13
Delta Versions	14
Installing and Uninstalling Delta	17
Terms and Definitions in Delta	19
<b>Part 1: DeltaServer Software</b>	<b>25</b>
DeltaServer Application	27
Status	27
Timeline Controls	28
Main Menu	28
Playback Window	33
Delta Supported Media and File Locations	39
Movies	40
Images	44
Audio	45
Effects	45
Edge Blending	45
Geometry Correction / Warp	46
Serial Events	46
Colour Correction	47
Splines	48
Art-Net	48
Containers	49
Shader Effects	49
Sequences	50
<b>Part 2: DeltaGUI Software</b>	<b>51</b>
Server Connections	53
Multi-Rack Control	57
Server List Dialog	57
Copy Timeline	57
User Interface	61
Main Menu	61
Workspace Menu	68
Server Selection	69
Timeline Selection	69
Status Bar	70

Layers Menus	71
Server Messages	76
Timeline Controls	77
Timing Area	78
Resources Area	79
Layers Area	81
Using Timelines	84
Toolbars	89
TCP Connections	91
Setting DeltaGUI Preferences	93
System Configuration	94
Startup and File Load Configuration	95
Default Paths Configuration	97
Disk Drive Configuration	97
Timing Configuration	99
Communication Configuration	102
Server Information	105
DeltaGUI User Interface	106
Preview Window / Record Preview setup	112
Misc Settings	113
Interactivity	114
Resource Defaults	116
Configuration Defaults	117
Extra Resource Paths	118
Audio Type	120
Audio Mapping	121
Art-Net and DMX Config	123
User Information / Stats	125
Display Configuration Features	127
Output Setup	128
Test Patterns	134
3D: Passive Stereo Mode	135
3D: Active Stereo Mode	137
3D Stereo Show Wizard	140
Display Configuration: Warp	142
Display Configuration: Blending	150
Display Configuration: Colour Balancing and Convergence	153
Display Configuration: Splines	155

Display Configuration Files (XDL files)	159
Display Configuration: Flat Plane Mode	161
Flat Plane Channel Arrangements	165
Flat Plane Output Channels	167
Flat Plane Preview Window Setup	167
Flat Plane Mode Defaults	169
Process: Flat Plane Align, Warp and Blend	170
Process: Setting Up Channels	172
Process: Warping to the Physical Surface	175
Process: Blending Flat Plane Channels	179
Process: Display Configuration Files	180
Using AutoAlign with Pre-warped Media	181
Display Configuration: Composition Mode	183
Composition Mode in DeltaGUI	188
Composition Mode and IntelligentSource	191
Display Configuration: Dome Mode	193
Dome Mode Views	195
Defining and Sizing Channels	200
Media Resources and Layers	204
Autoalignment Process: Preparation	206
Configuring Delta to use Autoalignment Data	208
Scalable Display Manager	209
Using MPCDI Data	217
Display Configuration: Mesh Mode	221
Projection and Textured Modes Explained	221
Mesh Mode Setup	225
Mesh Setup Basic Sequence	226
Setting an Eyepoint in Delta	227
DeltaGUI Mesh Mode Controls	228
3D Projector Calibration	235
Warping a Mesh	245
Blending in Mesh Mode	248
Troubleshooting Projection Mode	248
Working in Textured Mode	252
Multiple Meshes and Media	253
Active 3D Mesh Mode	255
Editing a Mesh	259
Movement Nodes	267

Mesh Optical Tracking	269
Switches	272
Populating the Timeline	274
Interact with Resources on the Timeline	276
Drag and Drop onto the Timeline	278
Group Selection of Media (Rubber Banding)	279
Media Placeholders	281
Replacing / Cloning Resources	282
Cutting, Splitting, Aligning, Looping Media	282
Markers	285
Seamless Looping a Timeline	290
Timing Controls Distribution	293
Disable, Lock or Delete Media	295
Outline Media	296
Presets	297
Using Media Resources	298
Resource Finder	298
Timeline Summary	299
Ingesting (importing) Resources	300
Configuring Resource Properties: the Resource Editor	302
Resource Editor: General	303
Resource Editor: Timeline	304
Resource Editor: Movie Files	309
Resource Editor: Audio Files	312
Resource Editor: Video Capture	314
Resource Editor: Spout capture	316
Resource Editor: Web Resource	319
Resource Editor: NDI Capture	322
Resource Editor: Stream Capture	325
IntelligentSource™	326
Video Capture Groups	328
Resource Editor: Controls Placeholder	332
Resource Editor: GoTo Control	332
Resource Editor: Text	334
Resource Editor: Keying (Chroma and Luma)	338
Resource Editor: Colour Controls	340
Resource Editor: Art-Net and DMX resources	340
Building a Show by Combining Resources	343

Screen Location (in Flat Plane or Mesh mode)	344
Resource Layout	345
Animation	349
Transform Animation	350
Geometry/Warp	353
Using Sequences	354
Serial Events	373
Colour LUTs	375
Splines	377
Art-Net and DMX	379
Playlist / AV Assembly	387
Timeline Effects	396
Shader Effects	397
Creating Slideshows	405
External Controls	409
Viewing and Previewing Shows	414
Using Delta Preview	415
Recording	419
Record a Show or Carve Media	419
Real-Time Recording	424
Art-Net Recording	426
Audio Equalisation	429
<b>Part 3: DeltaOffline</b>	<b>431</b>
Installing DeltaOffline	433
Running DeltaOffline	435
<b>Appendices</b>	<b>437</b>
Appendix A: External Control	439
External Control Commands	439
Return Codes	441
Troubleshooting External Control	444
Appendix B: Licensing the Server	445
Appendix C: SDI Output option	447
Appendix D: SMPTE/Transport Control Setup	449
Configure Delta for listening to an external 422 device	449
RS422 Transport Controls	451
Appendix E: Shortcut Keys	453
Appendix F: Command Line Switches	455
Appendix G: Troubleshooting	456

DeltaGUI will not connect to the server	456
Delta will not play smoothly	458
System Diagnostic Logs	459
Appendix H: Windows 10 Unified Write Filter	464
Appendix I: Express Mode, Creating Shows Programmatically	467
Configuring Delta for Express Mode	467
The JSON Structure	468
Ingesting into Delta	472
<b>Document Information</b>	<b>475</b>
Index	477



# Delta User Guide

## Delta User Guide

---

**Delta Media Servers:** the hardware that provide optimised superfast delivery of uncompressed video and audio across multiple synchronised devices to any number of output channels.

### [Part 1: DeltaServer Software](#) <sup>26</sup>

**DeltaServer:** the playback server software with comprehensive integration to external show control devices and a limited user interface. DeltaServer serves its shows into the Playback Window, which is usually shown full screen during playback.

### [Part 2: DeltaGUI Software](#) <sup>52</sup>

**DeltaGUI:** the graphical user interface with full editing capabilities. DeltaGUI allows full control over the display environment parameters, for multichannel, flat, curved, dome or mapped projection surfaces.

### [Part 3: DeltaOffline](#) <sup>432</sup>

**DeltaOffline:** this is a dongle licence-limited edition of the full DeltaServer and DeltaGUI software, designed for offline use by show creators on a PC rather than a Delta Media Server. Anything created in DeltaOffline can be played back without limitations on a full Delta licence with Delta Media Servers.

## Getting Help: Learning Delta

**This guide** covers the functionality of Delta Media Servers, using the DeltaGUI display setup, and creating shows from mixed media, multiple effects, and controls. The version described and illustrated here is Delta 2.7, but most of the principles are just the same as Delta 2.4 to 2.6.

### From DeltaGUI Help menu:

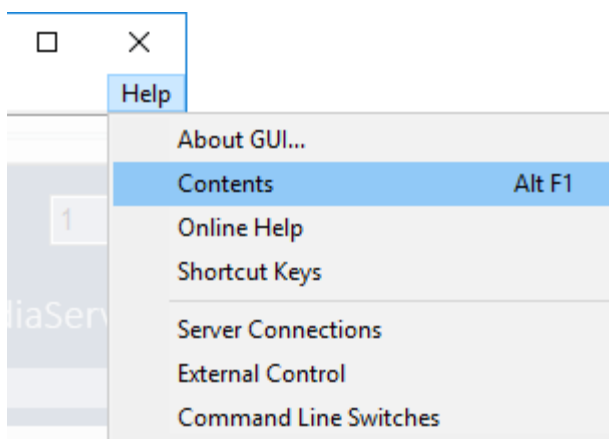

## **Contents**

opens the eBook guide installed with your software.

## **Online Help**

takes you to the latest online guides to all 7thSense Design products.

## Overview: Delta System Architecture

---

New starter? For workflow in Delta media systems, see:

➤ [Delta Workflow for New Users](#)

This includes installing and setting up a control PC with DeltaGUI.

Media shows and displays that are designed, shaped and sized for specific environments rely on systems integration to translate and control flat media and audio to real space.

**Delta Media Servers** are the hardware that provide optimised superfast delivery of uncompressed video and audio across multiple synchronised devices to any number of output channels.

**DeltaServer** is the playback server software with comprehensive integration to external show control devices and a limited user interface. DeltaServer serves its shows into the Playback Window, which is usually shown full screen during playback.

**DeltaGUI** is the graphical user interface with full editing capabilities. DeltaGUI allows full control over the display environment parameters, for multichannel, flat, curved, dome or mapped projection surfaces.

**DeltaGUI** is a comprehensive user interface to all instances of DeltaServer found on the network. DeltaGUI communicates through Ethernet, finding the server(s) automatically, and presenting the resources available for interactive editing. It contains all the tools to position, coordinate, and play multiple, layered timelines containing media resources, so users can create complex shows and save them to disk for later playback. DeltaGUI is not essential for playback, only for show creation.

**DeltaAudio** is a tray application and sub-component of DeltaServer, which runs automatically when DeltaServer launches, to provide a common interface to audio devices. This application is essential for audio playback.

**DeltaMonitor** is a tray application which provides communication to the front panel readout, EDID spoofing and some backup functionality. This application is essential for front panel updates.

**Delta Web Service** provides a web-based user interface to control multiple Delta servers. Control, Playback Preview, user-created control pages, and scheduling are built-in.

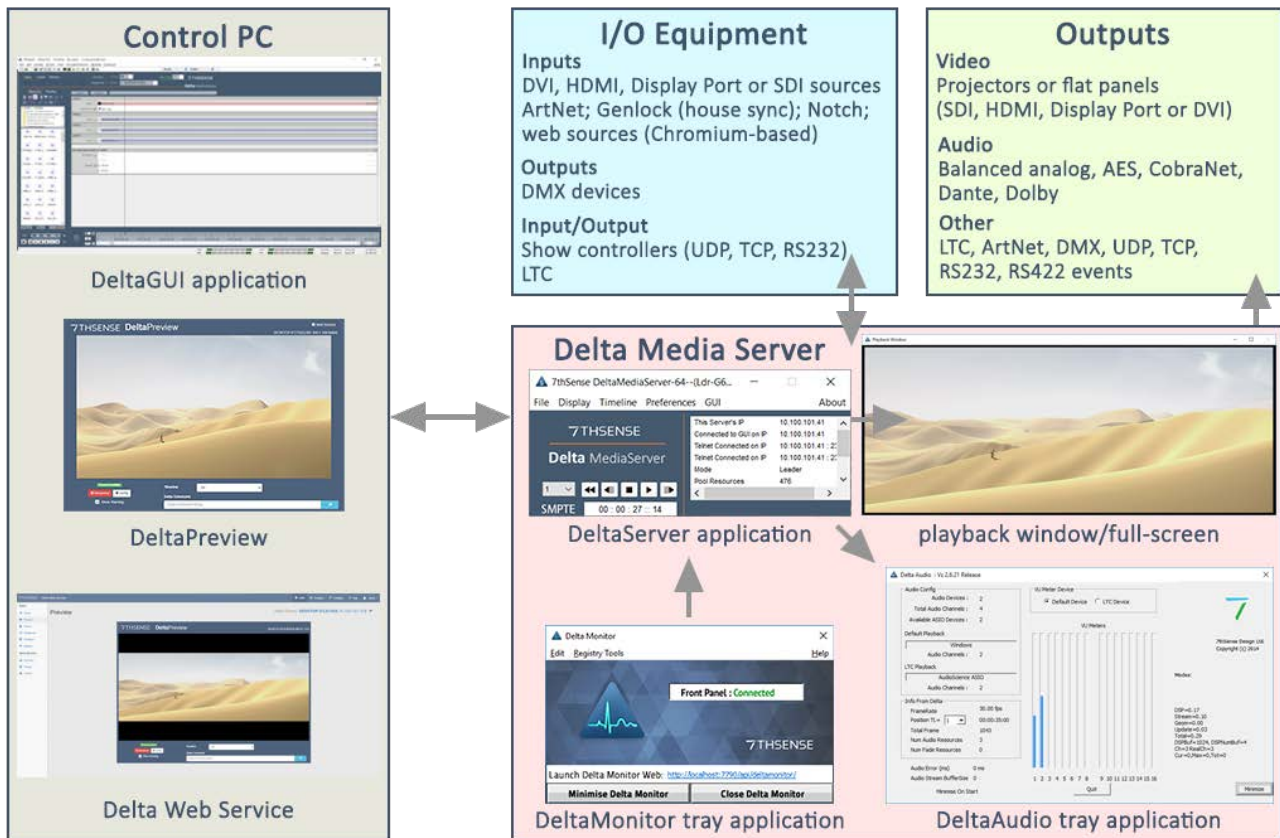

- Delta uses various ports and protocols, including servers scanning for an available GUI, so the Delta network should not be connected to an IT network or the internet, for security reasons as well as interruption of timing between racks.
- External Control is available to each Server through RS232 or Ethernet.

**This manual** covers the functionality of Delta Media Servers, using the DeltaGUI display setup, and creating shows from mixed media, multiple effects, and controls.

## Multi Rack Architecture

**Please note:** From 2020 7thSense deprecated the terms master and slave for the dependencies between devices. We now refer throughout to 'Leader' and 'Follower' in our products.

To maintain functionality, both terminologies continue to work internally, but our documentation no longer uses the former terms. Users of pre-2020 products will need to observe the equivalence and continue to use the previous legacy terms.

Delta is multi-rack capable, with the ability for DeltaGUI to be run from anywhere on the local network, on one of the servers or, more normally, a separate machine. The servers can be grouped together, with one as Leader rack, the others as Followers. The Leader rack then controls all timing, so that all machines in the same group are locked in time (playhead control in Follower servers is locked to the

Leader server, including any Stop and GoTo sequence commands). Only one instance of DeltaGUI can control a specific server group, at a time.

DeltaGUI and servers communicate via Ethernet on a Gigabit local network.

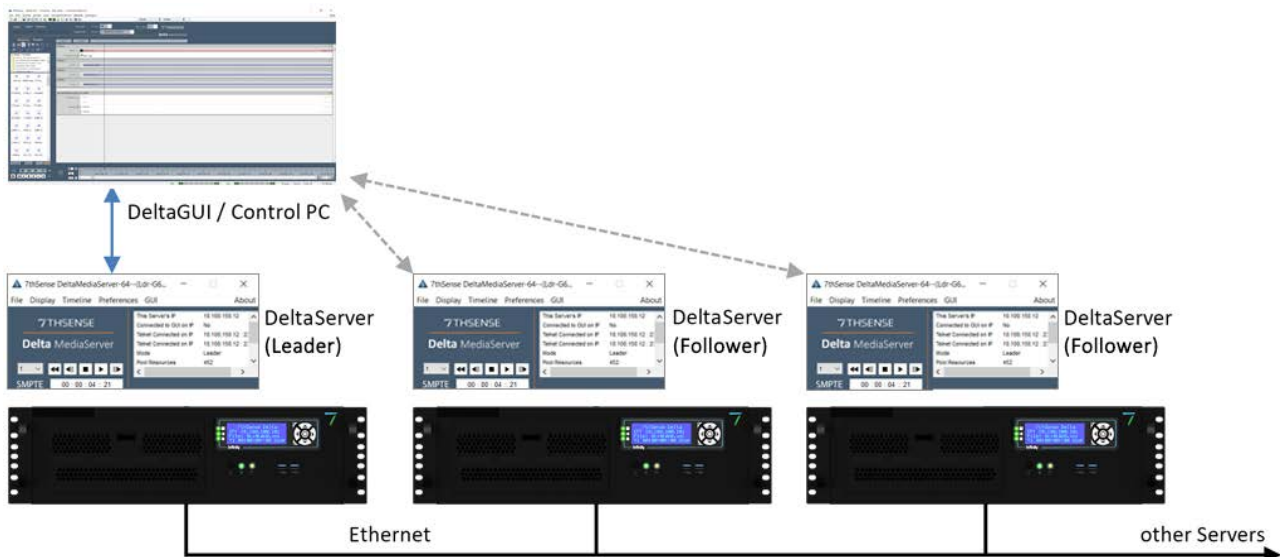

Choosing a particular server to view its resources, timeline or preferences is simply a matter of choosing the timing Group it lives in and then selecting the individual server by the server name. This name is the PC's machine name, which replaces the 'My Computer' desktop icon name. The text for the Computer Name is the name reported to DeltaGUI. By default, the name is the serial number, e.g. 'Delta3765'.

When interacting with multiple servers, you are presented with some multi-rack choices at certain times. For example, when choosing File New, you are asked whether you wish to perform this on the selected server, on all servers in this group, or on all servers.

When altering the Preferences, those shown are for the selected server.

## Delta Versions

7thSense Delta software is under constant improvement and enhancement to meet the needs of our users. This does not imply the need to upgrade any stable installation, unless you need new enhancements. However, it is important that the installed version and build number of DeltaGUI used, matches that of all the servers to which it is connected.

## Which version of Delta do I have?

### DeltaServer Version

Go to the DeltaServer **software dialog** menu: *About > About Server* for the server software version. Here (and in DeltaGUI > *Help > About*) you will find a precise build 'fingerprint', which you may be asked for when seeking 7thSense diagnostic support.

Alternatively, scroll left or right through the **server front panel** menu until you see 'Delta Version:' displayed.

**For a remote server**, the optional Stack web interface 'Overview' page also lists the version of every networked server, under 'Detailed Status':

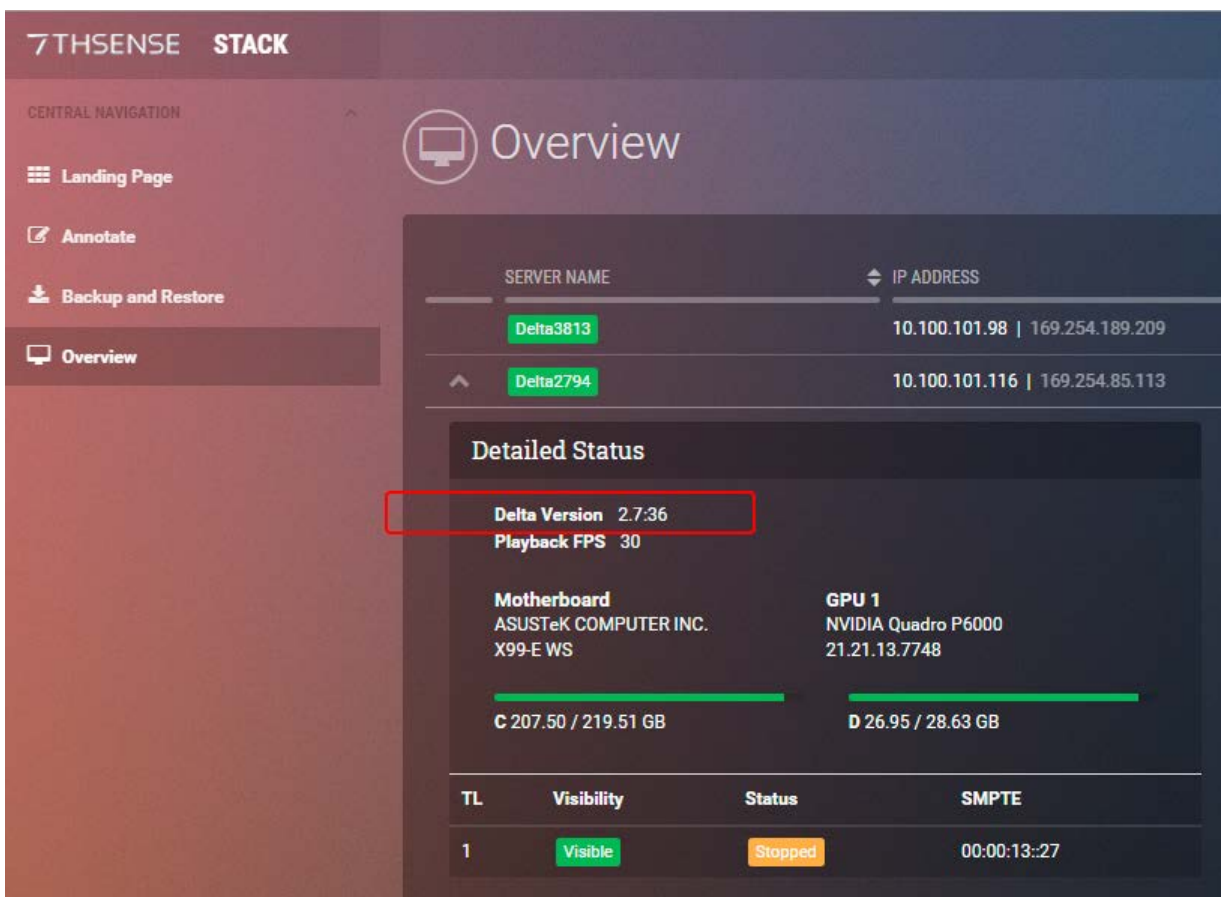

The screenshot shows the 7THSENSE STACK Overview page. The left sidebar contains navigation options: Landing Page, Annotate, Backup and Restore, and Overview. The main content area displays a table of servers with columns for SERVER NAME and IP ADDRESS. Below the table is a 'Detailed Status' section for a selected server, which includes fields for Delta Version (2.7:36), Playback FPS (30), Motherboard (ASUSTeK COMPUTER INC. X99-E WS), and GPU 1 (NVIDIA Quadro P6000 21.21.13.7748). A red box highlights the 'Delta Version' field. At the bottom, there is a table with columns for TL, Visibility, Status, and SMPTE.

SERVER NAME	IP ADDRESS
Delta3813	10.100.101.98   169.254.189.209
Delta2794	10.100.101.116   169.254.85.113

  

Detailed Status	
Delta Version	2.7:36
Playback FPS	30
Motherboard	ASUSTeK COMPUTER INC. X99-E WS
GPU 1	NVIDIA Quadro P6000 21.21.13.7748
C	207.50 / 219.51 GB
D	26.95 / 28.63 GB

TL	Visibility	Status	SMPTE
1	Visible	Stopped	00:00:13::27

Alternatively, you can send a **Telnet command** 'statusex' to its IP address (e.g. over the free PuTTY Telnet client), which will return VERSION=

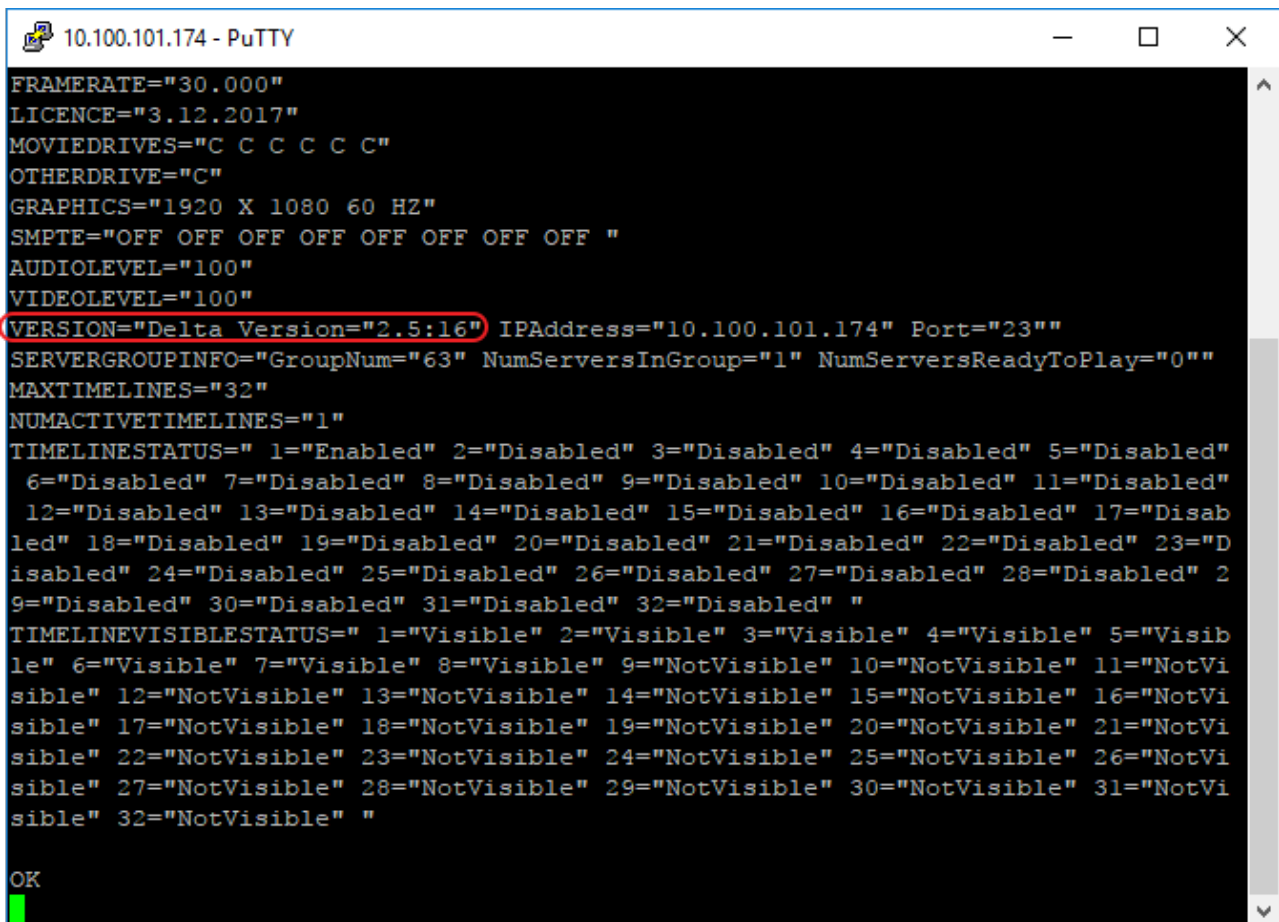

```
10.100.101.174 - PuTTY
FRAMERATE="30.000"
LICENCE="3.12.2017"
MOVIEDRIVES="C C C C C C"
OTHERDRIVE="C"
GRAPHICS="1920 X 1080 60 HZ"
SMPTE="OFF OFF OFF OFF OFF OFF OFF "
AUDIOLEVEL="100"
VIDEOLEVEL="100"
VERSION="Delta Version="2.5:16" IPAddress="10.100.101.174" Port="23"
SERVERGROUPINFO="GroupNum="63" NumServersInGroup="1" NumServersReadyToPlay="0"
MAXTIMELINES="32"
NUMACTIVETIMELINES="1"
TIMELINESTATUS=" 1="Enabled" 2="Disabled" 3="Disabled" 4="Disabled" 5="Disabled"
 6="Disabled" 7="Disabled" 8="Disabled" 9="Disabled" 10="Disabled" 11="Disabled"
 12="Disabled" 13="Disabled" 14="Disabled" 15="Disabled" 16="Disabled" 17="Disab
led" 18="Disabled" 19="Disabled" 20="Disabled" 21="Disabled" 22="Disabled" 23="D
isabled" 24="Disabled" 25="Disabled" 26="Disabled" 27="Disabled" 28="Disabled" 2
9="Disabled" 30="Disabled" 31="Disabled" 32="Disabled" "
TIMELINEVISIBLESTATUS=" 1="Visible" 2="Visible" 3="Visible" 4="Visible" 5="Visib
le" 6="Visible" 7="Visible" 8="Visible" 9="NotVisible" 10="NotVisible" 11="NotVi
sible" 12="NotVisible" 13="NotVisible" 14="NotVisible" 15="NotVisible" 16="NotVi
sible" 17="NotVisible" 18="NotVisible" 19="NotVisible" 20="NotVisible" 21="NotVi
sible" 22="NotVisible" 23="NotVisible" 24="NotVisible" 25="NotVisible" 26="NotVi
sible" 27="NotVisible" 28="NotVisible" 29="NotVisible" 30="NotVisible" 31="NotVi
sible" 32="NotVisible" "
OK
```

## DeltaGUI Version

Go to the DeltaGUI menu: *Help > About GUI*.

## Help, Support and Upgrading

Please always quote every element in the build description line.

If you require an installation package for a specific build of DeltaServer, please feel free to contact support@7thsense.one.



## Installing and Uninstalling Delta

---

### What is installed and where

In **C:\Program Files\7thSense\Delta**:

- DeltaAudio.exe
- DeltaGUI.exe
- Deltaserver.exe
- DeltaUninstall.exe

During installation, C:\Effects is created and populated.

In **C:\Program Files\7thSense\Delta\Guides**:

- the *Delta User Guide* and *Managing Delta Servers* in pdf and eBook formats (.exe)

In **C:\Program Files\7thSense\Delta\HelpFiles**:

- ExternalControlHelp.html – the web page of all external control and sequence commands

In **C:\Program Files\7thSense\Delta\Licensing**:

- Licence.txt (7thSense licence terms)

In **C:\Program Files\7thSense\Delta\Sequences**:

- Sequences.xml (core system sequences)

In **C:\Program Files\7thSense\Delta\System**:

- configuration files for Delta applications

In **C:\Program Files\7thSense\Delta\Utilities**:

- 7thMovieViewer64.exe
- 7thUDP2TCP.exe
- 7thUDPAppLauncher.exe
- AudioMapper.exe
- BackPack.exe
- DeltaFinder.exe
- DeltaMonitor.exe
- plus other files used by Delta and optional applications.

## Uninstalling with DeltaUninstall.exe

- Removes all files from C:\Program Files\7thSense\Delta\ and creates a \backup folder in the same location, and removes folder C:\Effects.

## Backup folder contents

**\Logs** (all files from C:\Program Files\7thSense\Delta\Logs, all files from C:\Program Files\7thSense\Delta\Utilities\Logs, DeltaMonitorLog.txt from C:\Program Files\7thSense\Delta\), plus these logs:

- bpLog
- DeltaAudioDebugLog
- DeltaMonitorLog
- DeltaServerDebugLog

**\Sequences** (copied from C:\Program Files\7thSense\Delta\Sequences)

**\System** (all files from programfiles\7thSense\Delta\System)

and from C:\Program Files\7thSense\Delta:

- **installhistory.log** which contains the install date and version of Delta
- **version** – the version of Delta that has been deleted.

**When uninstaller is run, any previous backup folder is completely deleted and then recreated.**

All C:\ user asset folders for images, movies, audio, shows, etc. are not touched by the uninstall process.

## Terms and Definitions in Delta

Term	Context	Explanation
29.97	media	NTSC standard, the TV broadcast video framerate, originating from early colour TV transmission problems between chrominance and audio carrier signal phasing at 30 fps. Resolved through use of <a href="#">drop frame</a> <sup>(19)</sup> timecoding.
3D active	display	Active 3D separates left and right eye images by displaying them as alternate frames, with synchronised battery-operated shutter glasses to allow eyes also only to see alternately.
3D passive	display	In passive 3D, left and right eye images are separated by cross-polarisation of alternate pixel rows by the projectors, and glasses with polarising lenses in opposing axes. Effectively the eyes see alternate rows.
Art-Net	show creation	A UDP communications protocol for DMX512-A lighting control and for remote device management (RDM).
azimuth	projection	See <a href="#">heading</a> <sup>(20)</sup> .
blend	display	Overlapping projectors are used to create seamless continuous display. Edge blending adjusts the amount of overlap and consequent increased intensity of the overlapped display area. A single channel, mesh or textured image can also be blended to soften its edges. In Delta, blends can also be shaped and fully characterised.
canvas	display	The total area or display surface to be covered by projection media by a DeltaServer show.
carving	media	A means of reducing overall server load by cutting media frames down to just the area required per channel. Typically employed for large dome displays.
channel	display	The feed route, in or out, of media, or part of total media of a multi-channel system (audio channel, L / R / Rear / etc.; projection channel covering part of the canvas, or display panel area).
channel view	display	The section of a canvas 'seen' by a display or projection channel.
chroma key	show creation	Sets which colour will become transparent to layers below.
composition mode	display	The arrangement of compacted media frame elements on a canvas.
display	display	The total surface receiving a visual channel or arrangement of channels.
distortion: point	display	Distortion of a surface by the displacement of a node or nodes to affect an area of the surface.
distortion: surface	display	Smooth overall distortion of an image or channel around midlines or corners.
distortion: timeline	display	Bowing, skewing and stretching an image or channel.
dome mode	display	Projection of media onto a spherical or elliptical surface.
drop frame	media	In order to match video at 29.97 fps with real time clocks at 30 fps, this time code drops two frames every minute, on the minute, except every tenth minute. Drop frame timecode is written with a semi-colon

Term	Context	Explanation
		HH:MM:SS;FF
EDID	display	Extended Display Identification Data. A metadata format describing properties and capabilities of a display device for communicating to a video source (graphics card), thus maximising compatibility without the need for manual configuration.
EDID emulation	display	Also called 'spoofing', the graphics card can read a proxy source rather than the actual display's EDID. Delta Media Servers use software EDID emulation to maintain the required grouping arrangement on working displays should one (or more) display fail. If the display EDIDs are not emulated, and connection between server and a display is broken, then the display arrangement reverts to single display mode, causing media distortion across the working displays, or black output across multiple displays.
effect	show creation	Manipulation of an image or channel to change its appearance; any form from fading to Notch effects.
elevation	projection	See <a href="#">pitch</a> <sup>(22)</sup> .
enumerate	general	When Delta programs generate lists of servers, media &c.
eyepoint	display	The point from which a display is ideally viewed; the viewpoint from which media has been designed.
follower	system	A server assigned to follow the playback activity of a leader server.
foot-lamberts (ftL)	projection	A measure of the amount of light reflected per square foot by a screen. SMPTE recommends 16 ftL as the level for a dark theatre. This would increase to maybe 60 ftL in situations of high ambient light.
frame rate	display	The rate at which a frame-based video sequence is meant to be played back, expressing frames per second (fps). For an audio track, the video playback rate to which it is synchronised in production. SMPTE <a href="#">LTC timecode</a> <sup>(22)</sup> tracks have standard frame rates.  In DeltaServer, media assets run on a timeline with its own defined framerate. For smooth playback, the Delta timeline frame rate should match or be a multiple of the display refresh rate (e.g. the timeline/content could be 25 fps, while the output refresh is 50 Hz). See also <a href="#">refresh rate</a> <sup>(22)</sup> .
frustum	projection	The pyramidal section representing the rectangular field of view of a projector or camera.
genlock	time & timing	The synchronisation of devices by linking them to a common timing signal.
group	system	A master-slave(s) relationship of two or more servers to synchronise their timing.
heading	projection	Angular displacement 'west' of 'north' (0-180° -ve) or 'east' of 'north' (0-180° +ve) where 'north' is straight ahead of the projector / observer. In movement, equivalent to yaw; in astronomy, azimuth.
house sync	time & timing	Method by which an signal generator produces the time reference (clock signal) for all genlocked servers in group, together with their channel outputs and devices. The signal may be a square-wave pulse or word clock for audio synchronisation.
interactive view	projection	In dome and mesh mode, moves the model around to enable the viewpoint to be changed in DeltaGUI and the playback window.

Term	Context	Explanation
layer	show creation	Also sublayer: render priority of simultaneous media.
leader	system	The server assigned to determine the timeline activity of a group.
location	display	Co-ordinates of media on a canvas, relative to the top-left corner or centre.
LTC timecode	time & timing	LTC Timecode, or longitudinal timecode, is a SMPTE standard (see SMPTE 12M specification) for encoding a timecode on an analog audio waveform. It is called longitudinal, because it was originally recorded lengthwise alongside other audio/video tracks on audio tape or film. In the digital world, it is more often handled as a separate audio track element that would be played in sync with other audio/video tracks, or used as a positional reference signal sent out from one device to another via an audio output, and an interpreting input at one or more receivers. These receivers can then 'chase' the source. LTC timecode has a disadvantage in that it cannot be read in a static state, because the timecode is rolled out over time (longitudinally), so the audio signal must be 'rolling' for a receiver to interpret it, and receivers require some short amount of 'pre-roll' time before they lock to the signal. The standardised timebases for LTC time are 23.98, 24, 25, 30 drop-frame, and 30 non-drop.
LTC chasing	time & timing	Synchronising playback to a reference LTC audio signal.
luma key	show creation	Sets which monochrome luminance value will become transparent to layers below.
lumen (lm)	projection	SI or ANSI unit of total amount of emitted visible light. Used as a measure of projector brightness. Higher brightness generally implies higher available contrast.
Lux (lx)	projection	The unit of luminance (1 lx = 1 lm/m <sup>2</sup> ) but see <a href="#">screen gain</a> <sup>(22)</sup> .
master	system	(deprecated term) The server assigned to determine the timeline activity of a group.
mesh	display	A polygon mesh is a 3D graphic surface constructed from faces joined by straight common edges. The end of an edge is a vertex, so a mesh can also be described as the set of vertices that define a polyhedral 3D surface.
mesh mode	display	The Delta display mode for mapping media onto a 3D surface based on a computer graphics object model of it.
MPCDI	display	Multiple Projection Common Data Interchange. A <a href="#">VESA</a> <sup>(23)</sup> standard data format for projection calibration systems to communicate with devices in a multi-display configuration to produce seamless displays. (Version 1, 2013; Version 2, 2015)
NDI®	comms	Network Device Interface developed by NewTek. A royalty-free IP standard for allowing multiple video streams on a shared connection. NDI supports high quality, low latency, frame-accurate video over standard Ethernet networks.
node	display	Any selectable intersection point on a geometric grid or mesh.
non-drop frame (NDF)	media	30 fps timecode video source played back at 29.97 fps. Note that being played more slowly this drifts from real time.
NotchLC	media	A Luma & Chroma (YUV) codec that achieves compression rates between 5:1 and 8:1 with minimal perceived quality loss. Suitable for very large canvases, from Delta 2.8.

Term	Context	Explanation
OSC	show control	A network messaging protocol originally designed for musical performances or show control. Introduced with Delta 2.8, provides a dynamic, configurable and low-latency interface for Delta External Control commands.
pitch	projection	Angular displacement above (0-180° +ve) or below (0-180° -ve) the horizon from the observer / projector. Also referred to as altitude or elevation.
preview	show review	Web-based view of the Delta playback window.
real time	show creation	Real time clocks (RTC) 'tell the time' rather than relative time displacement. DeltaRealTime is an application that enables gaming-style assets in real time to be integrated into timeline playback media.
refresh rate	display	Refresh rate is the number of times an output image is drawn, per second, whether in a digital projector, an LED display panel or a monitor display. Expressed as frequency, e.g. 60 Hz. See also <a href="#">frame rate</a> <sup>(20)</sup> .
reserve timeline	show creation	Delta can fade from the current playing timeline to a Reserve Timeline to enable fading back to a different position in the current timeline.
roll	projection	Angular displacement around the north (normal forward) axis, anticlockwise (0-180° -ve), clockwise (0-180° +ve).
screen gain	projection	Ratio of projected light to screen-reflected light, usually in the same axis. As the viewing angle increases away from this axis, gain will decrease (the screen appears progressively less bright). A gain of 0.8 means 80% of the projected light is reflected back. A screen with a gain higher than 1 implies that the reflected light is focused to a narrower angle than the incident light (which also means a narrower viewing angle). The highest gain screens can cause hot spots and reflect colours unequally. Lower gain screens will reduce light scatter in a dome theatre, for example 0.55. For 'screen brightness':  lumens ÷ screen area × screen gain = ftL (see also <a href="#">foot-lamberts</a> <sup>(20)</sup> .)
sequence	show control	User-editable macros which can be called at any time from DeltaGUI or via external control. They are useful for assembling a list of commonly-used playback controls.
slave	system	(deprecated term) A server assigned to follow the playback activity of a leader (previously master) server.
SMPTE		Society of Motion Picture & Television Engineers: professional membership and standards-setting association ( <a href="http://www.smpte.org">www.smpte.org</a> )
spline	show creation	A linear path described by Bezier curves for a resource to move along.
tearing	time & timing	Display image discontinuity caused by display synchronisation problems.
timecode (SMPTE)	time & timing	An 80-bit data format in HH:MM:SS:FF (the range of frames FF being the number of frames per second).
timecode (generic)	time & timing	A coded signal which carries timecode positional information for coordination of devices. The most common formats of timecode signal are <a href="#">LTC</a> <sup>(21)</sup> and <a href="#">VITC</a> <sup>(23)</sup> .
timeline	show creation	A space in DeltaGUI measured in <a href="#">SMPTE timecode</a> <sup>(22)</sup> along which layers of media, effects and controls can be arranged to create a show or part of a show.

Term	Context	Explanation
timing mode	time & timing	In Delta: display a Delta timeline in <a href="#">SMPTE</a> <sup>(22)</sup> , frames or seconds.
transition	show creation	Any time-spanned effect moving from one visual state to another, e.g. fade, transparency, morph
vertex	media	A point of intersection in a 3D graphical model where edges or polygonal faces meet.
vertex group	media	A group of linked vertices in a graphical model; can be one element in an .obj file.
VESA		Video Electronics Standards Association
viewport	display	The visible portion of a total image or canvas.
VITC Timecode	time & timing	VITC Timecode, or vertical interleave timecode, is a <a href="#">SMPTE</a> <sup>(22)</sup> standard for encoding a timecode signal into the vertical blanking interval of a video signal. VITC has a very similar payload definition to LTC, but has the advantage of being able to be read back even when the video is playing back very slow or stopped. Whilst often used in production, VITC is very uncommonly used for Pro AV device positional coordination today, because it requires embedding in a video signal versus a more easily processable audio waveform.
warp	display	Alter the geometry of a display channel or image, mainly to match flat media to a non-flat display surface.
WebRTC	show review	Web Real-Time Communication streams Delta playback over IP for viewing in a web browser.
word clock	time & timing	A digital audio signal designed for keeping digital audio devices in sync with a constant, precisely-timed bit-rate of 44.1 or 48 kHz.
zenith	projection	The point directly overhead of the projector / observer (pitch = 90°).

[^ top of page](#) <sup>(19)</sup>





# Part 1: DeltaServer Software

## Part 1: DeltaServer Software

---

Delta Media Servers hold all the media resources, each delivering up to 16 video channels and up to 32 audio channels. One server may do all the work, or they can be grouped as Leader and Followers to distribute and optimise performance. Show creation and display alignment uses the DeltaGUI application, running on a separate PC or laptop, communicating over Ethernet to the DeltaServer software. All user-created shows, media and settings are stored on the Delta Media Server so that the DeltaGUI is not required during normal daily running of the show. A subset of show and server controls is available over the web interface built into the server, including a live streamed preview of the show.

## DeltaServer Application

The DeltaServer software comprises the server user interface and the playback window. In normal operation, the Delta PC runs DeltaServer on boot and starts the Playback Window in full screen mode, then plays the default show chosen by the user.

To access the DeltaServer user interface on the server, press the **F** key if looking at the Playback Window to toggle full screen mode off (press **F** again to restore full screen).

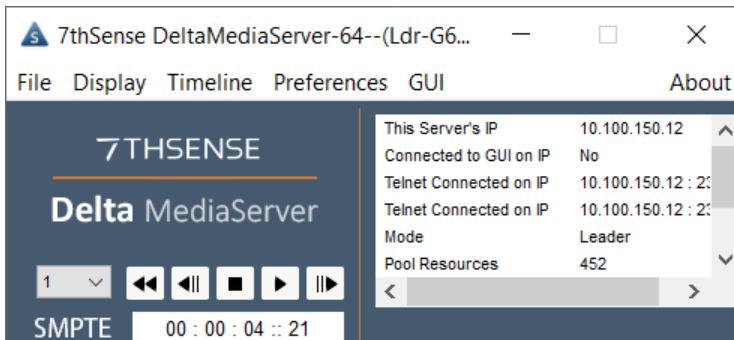

## Status

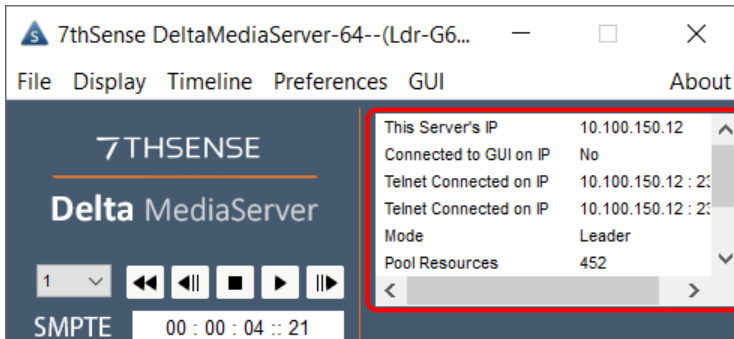

### This server's IP

Shows the current IP Address, set in the Windows Local Area Network dialog (Internet Protocol settings)

### Connected to GUI on IP

shows the DeltaGUI IP address when connected

### Telnet Connected on IP

shows a list of current Telnet connections

### Mode

Leader or Follower

**Pool Resources**

shows the total count of resources found on the media disk(s)

**Timeline Resources**

shows the total count of resources on all timelines for this show

**Telnet IP**

shows the Telnet address when connected

## Timeline Controls

---

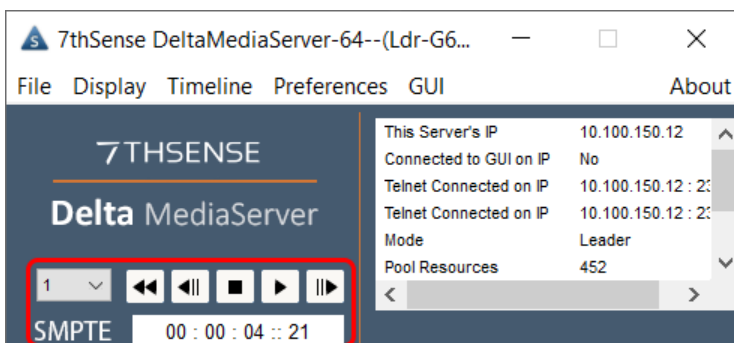

The SMPTE time code is shown on the left, then playback controls; Rewind, Step Back, Stop, Play, Advance. Note these only appear on a Leader server.

Hold Shift whilst clicking the play button and play will reverse. The playbutton will stay in reverse mode until Shift+Play are combined again.

## Main Menu

---

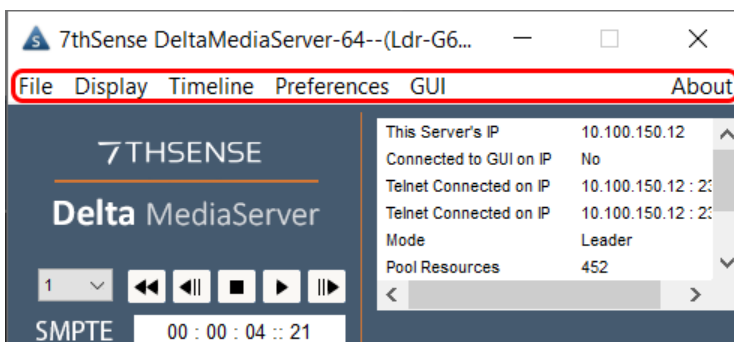
**File**

From this menu, you can Load or Save a Delta file, clear the timeline (*File > New*), exit the application (*File > Exit*).

## Display

Toggle the Playback Window between full screen and windowed, using the View menu.

## Timeline

Jump to a specific frame using the *Timeline > Jump to Frame* menu.

## Preferences > System

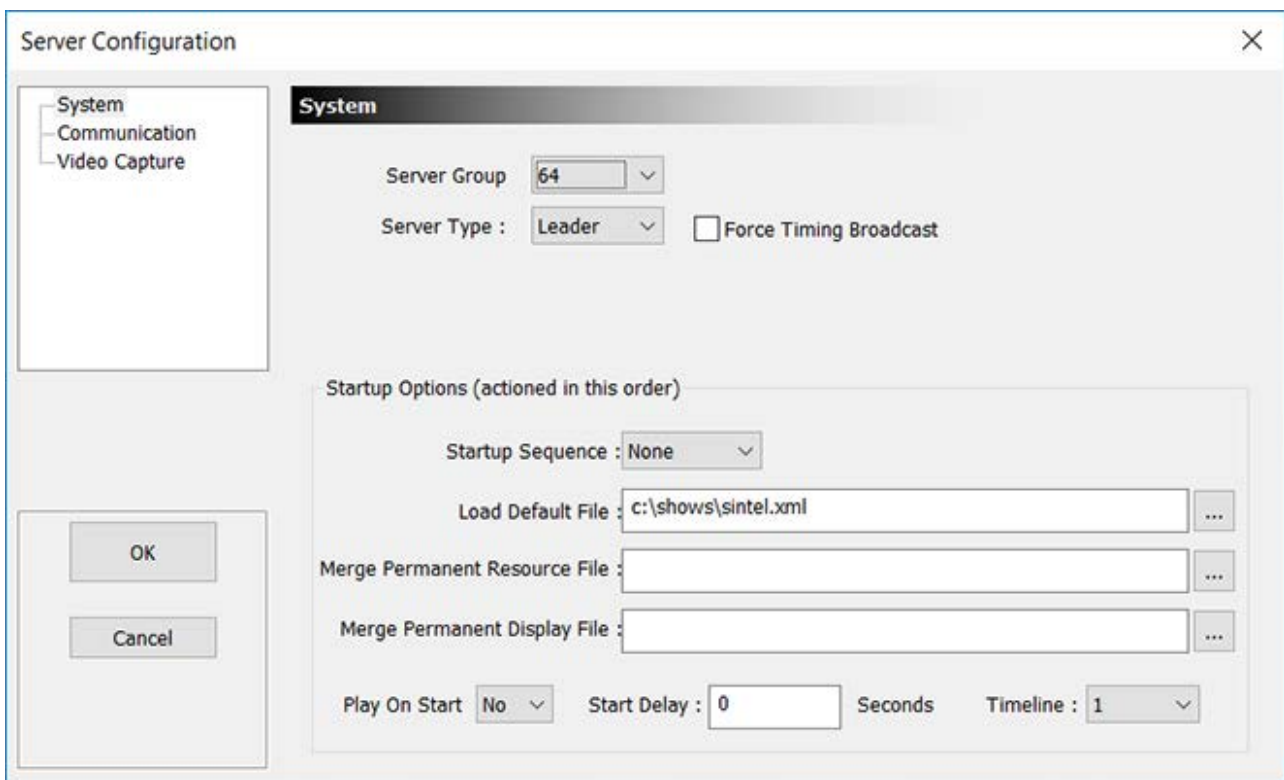

This simple dialog allows you to set basic server parameters such as:

### Server Group

which group this server belongs to (1-64)

### Server Type

Leader or Follower

### Force Timing Broadcast

By default, timing packets are not broadcast if no Follower servers are detected in this group (in order to lower network traffic). Enable this option to always force timing packets to be broadcast in case other equipment depends on that timing.

**Startup Options (actioned in this order)****Startup Sequence**

This sequence will be run on boot.

**Load Default File**

a full path to the default Delta show

**Merge Permanent Resource File**

a full path to the Delta show that will be merged after loading the main show (for masks etc.)

**Merge Permanent Display File**

Set an XDL file to be loaded after any file load (see display configuration files -xdl files).

**Play On Start**

If Yes, the Default file will be played when Delta starts, after the main show is loaded, before it starts playing.

**Start Delay:** the seconds to wait before loading the default show

**Timeline**

which timeline to play on start

**Note: Start Delay**

Since Delta can play a show immediately after the PC boots, having a delay before Delta loads and plays the default show allows the various Windows boot procedures to finish using any network, CPU or disk resources that could interfere with Delta's playback, for example to receive a valid IP address if using DHCP from a network device.

It is recommended to set Follower Delta servers to a delay of at around 20 seconds, and a Leader Delta server to 30 seconds to ensure the Follower servers are ready to play as a group.

## Preferences > Communication

The screenshot shows the 'Server Configuration' dialog box with the 'Communication' tab selected. The dialog has a sidebar with 'System', 'Communication', and 'Video Capture' options. The main area contains the following settings:

- Server: DESKTOP-DTJOJSA at 10.100.101.174
- Network: 10.100.101.174 : Intel(R) 82579V Gigabit Network Connection
- Command Port: 7001 (Default: 7001)
- Search Port: 7002 (Default: 7002)
- Timing Port: 7003 (Default: 7003)
- Telnet Port (TCP): 23 (Default: 23)
- Telnet Port (UDP): 7780 (Default: 7780)
- Enable GUI Comms Timeout: 0 Seconds
- Enable Telnet Comms Timeout: 0 Seconds

A note on the right side states: 'Note that changes on this page only take place when you restart the server'. The dialog includes 'OK' and 'Cancel' buttons at the bottom left.

- Set the ports for DeltaGUI / Server comms. Leave as default unless there are specific network restrictions, so that a default installation of DeltaGUI will find the server. If non-default ports are used, configure any DeltaGUI applications to also use these ports.
- Choose which Ethernet adapter to use and what ports.
- Set optional DeltaGUI and Telnet timeout in seconds – use this if there is a possibility of the network being removed so that the DeltaGUI can reconnect.

## Preferences > Video Capture

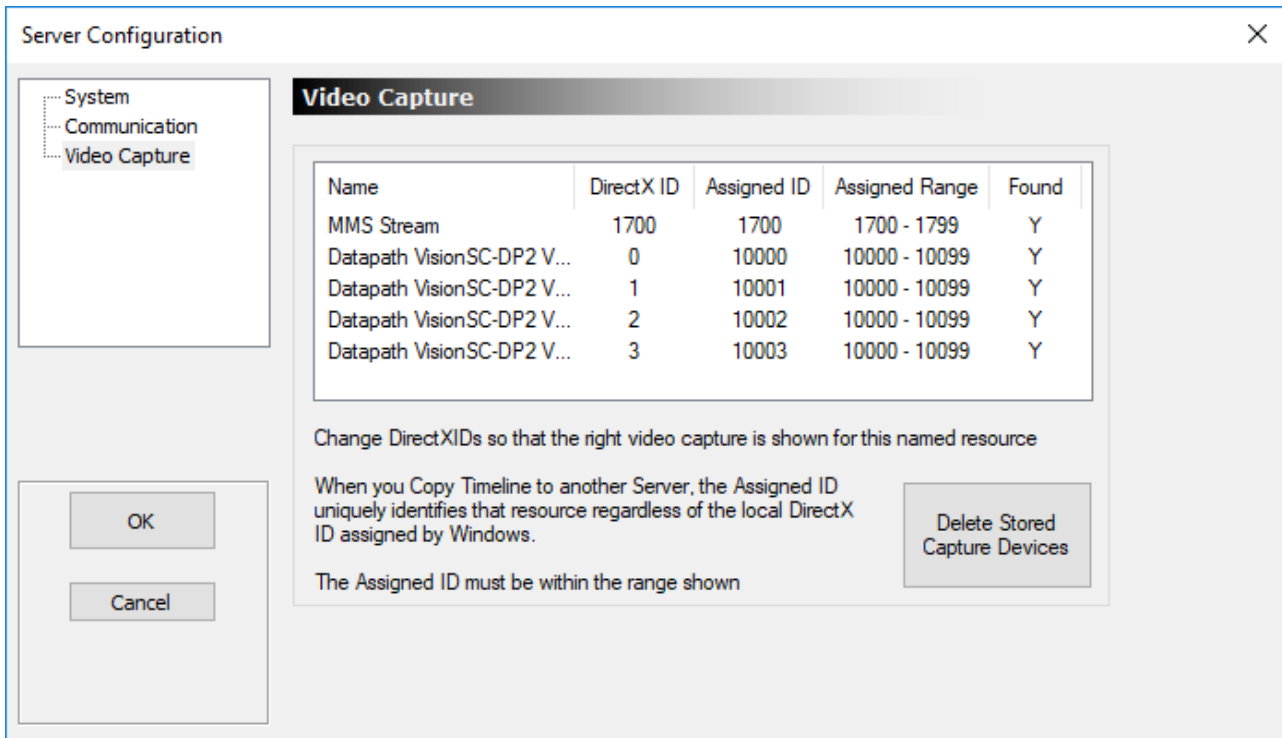

This page lists any capture devices found and their assigned IDs which map physical input connectors to the resource on the timeline.

Normally, this list is populated automatically and needs no interaction, but if, for example, you would like to swap the IDs around on a multiple input card, you can edit the Assigned ID for each card here – this will be remembered in the registry next time the server application starts.

**Note:** do not allow two devices to have the same Assigned ID.

Delete Stored Capture Devices – press this button to remove all capture devices and enumerate them again. Note this loses any previously edited Assigned IDs and is usually only used if a capture device has been removed physically from the server, but the driver has not been removed properly – this process attempts to find only real hardware.

## GUI

Close DeltaGUI (wherever it is open) from this server.



## About

### About Server

DeltaServer software and licensing details.

### Shortcut Keys

See [Appendix E: Shortcut Keys](#) <sup>453</sup>

### Command Line Switches

See [Appendix F: Command Line Switches](#) <sup>455</sup>

### Update Licence

See [Appendix B: Licensing the Server](#) <sup>445</sup>

### Save System Log

See [System Diagnostic Logs](#) <sup>459</sup>

### Show External Control Traffic

See [Troubleshooting External Control](#) <sup>444</sup>

## Playback Window

---

The playback window launches with DeltaServer. It can be toggled full-screen with the DeltaServer menu option: Display, or just by keying F. This window is not sized to the canvas.

### Timecode / Movie Timecode Display

Drag either or both Timecode resources from the Resource (Text) pool onto the timeline, and enable or disable as required. The text size, colour, opacity and position are set in the resource properties (double-click, or right click the text resource on the timeline for the Resource Editor).

### Information and Performance Display

Information can be overlaid on the show, as seen here (the same is available to be viewed in Web Preview). **Top left:** timeline information, **bottom left:** playback settings, **bottom right:** audio VU meter bars, and in the **centre:** the playback performance graph (with legend, top right).

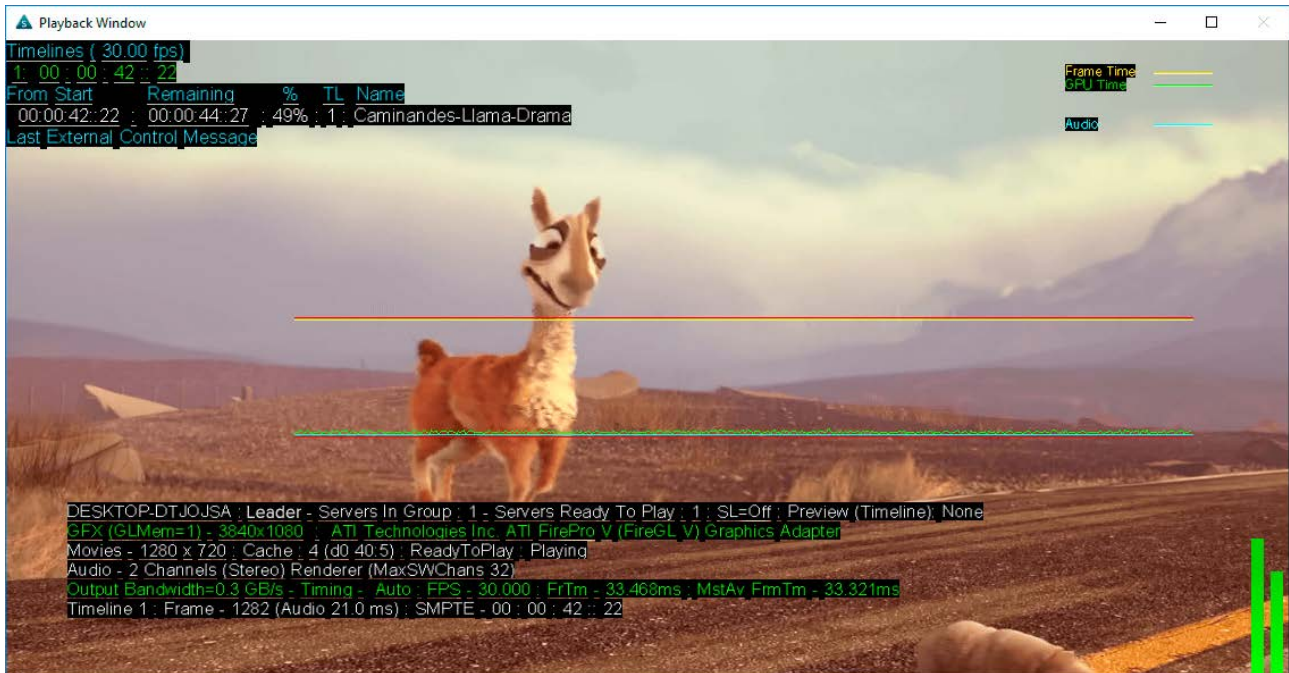

If enabled in *Preferences > User Stats*, the features available can be switched on and off with quick keys:

**G** : view the **graph**

**I** : view the **timeline information** (shown top, above)

**A** : view the **audio VU meter**

**S** : view the **playback stats** (shown as the lower block, above)

The following view adjustments are persistent whilst DeltaServer is running, and have been used in the illustration above:

**Shift+arrows** : Position the playback statistics on screen

**Ctrl+arrows** : Size the width and height of the playback statistics block (and type size)

**Ctrl+Shift+arrows** : Position the graph block

**Ctrl+Shift+Q/W** : Make graph block narrower/wider

**Ctrl+Shift+Y/H** : Make graph block taller/shorter

## Interpreting the information

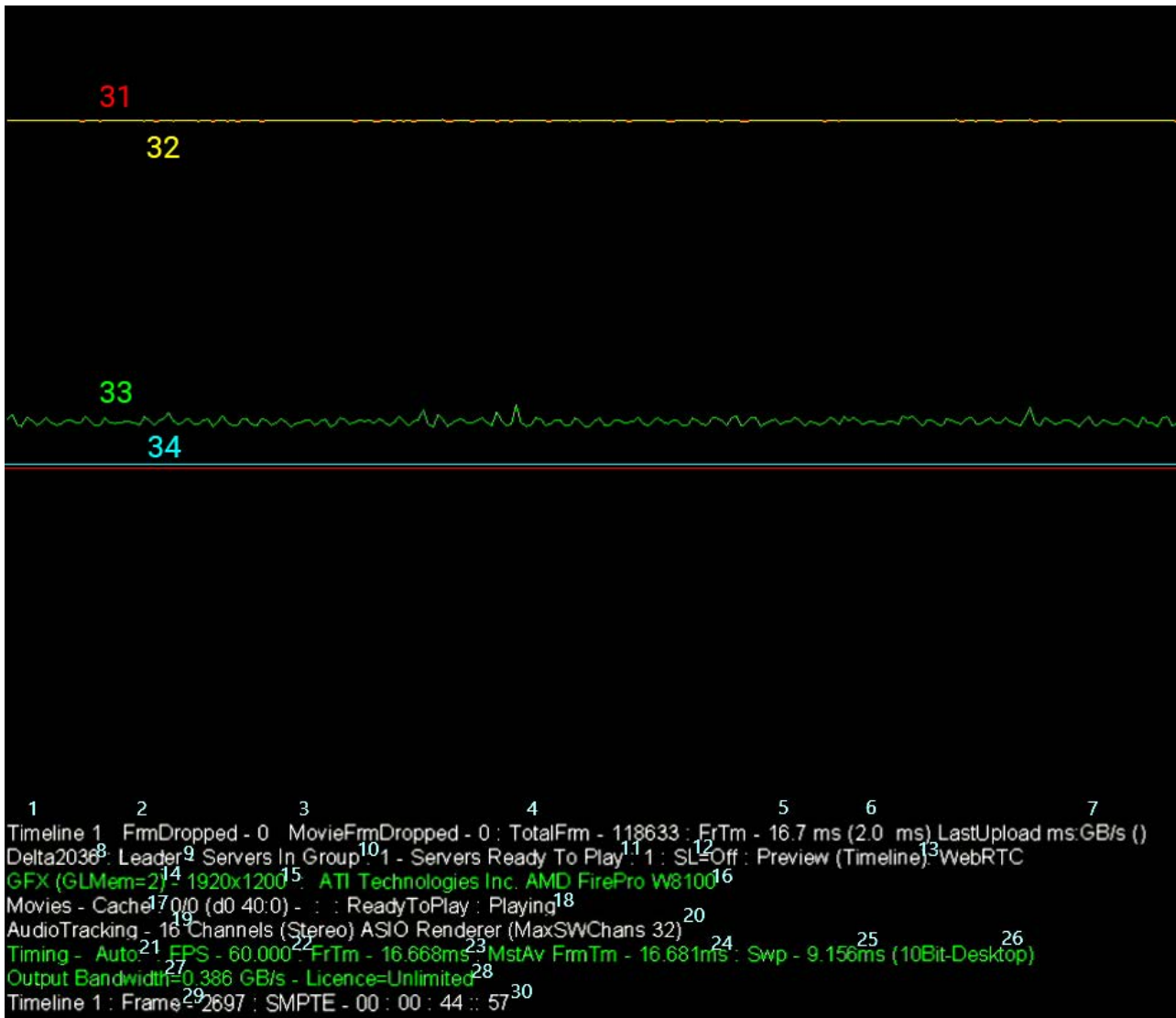

1. **Timeline 1** – Indicates the Timeline selected in DeltaGUI.
2. **FrmDropped** – Indicates the number of dropped graphics frames since last reset. Dropped frames can be caused by many things, including open VNC windows, non-fullscreen playback, additional applications running, timing issues, or graphics overloading.
3. **MovieFrmDropped** – Indicates the number of dropped Movie frames since last reset. Movie frames drop when the disk bandwidth cannot keep up with the read request bandwidth in playback. This may happen with too many movies on the timeline, too large of files for a specified system, or indicate drive failures.
4. **TotalFrm** – Indicates the number of frames (always increasing) since the show load.
5. **FrTm** – Indicates the nominal time in ms per frame.
6. **FrTm()** – Indicates the time in ms that the current frame goes through render loop. (A developer debug tool only.)

7. **LastUpload ms:GB/s ()** – Indicates the upload time of the last asset.  
(A developer debug tool only.)
8. **Delta2036** – Delta Sever / PC Name.
9. **Leader** – Indicates if this server is a Leader or Follower.
10. **Servers in Group** – Indicates the number of Delta Media servers in a given server group.
11. **Servers Ready to Play** – Indicates the number of Delta Media servers in this server's group that are cued.
12. **SL=off** – Indicates whether Seamless Loop is enabled or disabled.
13. **Preview (Timeline): WebRTC** – Indicates that Preview is enabled with the device name: WebRTC.
14. **GFX (GLMem=2)** – Indicates the registry setting: MoviesUseLocalGLMem = 2.
15. **1920 × 1200** – Indicates the graphics resolution of the desktop (when in desktop playback mode).
16. **ATI Technologies Inc: AMD FirePro W8100** – Identifies the GPU in use by the Delta Media server.

[SDI systems insert a line containing SDI performance indicators, status of Direct DMA (direct memory access), and SDI frame format.]

17. **Movies – Cache 0/0 (d0/40:0)** – Indicates the number of movies and resolution of those movies for playback.
18. **ReadyToPlay : Playing** – Indicates Delta Media server's play status.
19. **AudioTracking** – 16 Channels (Stereo) – Indicates the number of audio channels for which Delta is configured.
20. **ASIO Renderer (MAXSWChans 32)** – Indicates the maximum number of parallel Audio voices, set in the GUI preferences. The setting dictates the total number of audio tracks allowed to be loaded into RAM for playback. Exceeding the maximum parallel voices (for instance by having 4 qty 8-channel audio files and 2 single-channel audio files overlapping on the timeline) will result in not all audio channels being audible.
21. **Timing – Auto** – Indicates the timing mode as set in the DeltaGUI Preferences > Timing tab. Auto will choose the best timing method for smooth playback.
22. **FPS – 60.000** – Indicates the framerate as set in the DeltaGUI Preferences > Timing tab.
23. **FrTm – 16.668ms** – 1000ms / FPS
24. **MstAv FrmTm – 16.681ms** – indicates the actual framerate (master average) at any given time. This value will fluctuate slightly on normal playback.
25. **Swp – 9.156ms** – Indicates the difference in frame time and upload time.
26. **(10Bit-Desktop)** – Indicates that the desktop settings, Delta registry settings, and cabling are all set for 10-bit mode. This message will not appear in 8-bit mode or if any of these values do not allow for 10-bit desktop mode to be active.
27. **Output Bandwidth=0.386 GB/s** – Indicates the bandwidth used under the current graphics setup. (Desktop resolution \* framerate \* RGB when in desktop mode).

28. **Licence=Unlimited** – Indicates the licenced bandwidth allotment for this Delta Media server. Exceeding this value will overlay a 'Bandwidth Exceeded' message on the output raster.
29. **Timeline 1 : Frame – 2697** – Indicates the current frame number of the specified timeline.
30. **SMPTE – 00 : 00 : 44 :: 57** – Indicates the SMPTE time of the specified timeline.
31. **RED LINE** – A reference line to the timing value specified in 5/23, over time.
32. **YELLOW LINE** – A reference line to the timing value specified in 24, over time.
33. **GREEN LINE** – A reference line to the timing value specified in 6, over time.
34. **BLUE LINE** – A reference line to the audio stray in ms, over time.

SDI systems insert a line containing timing data, status of Direct DMA (direct memory access), and format

## What the Graph Lines Mean

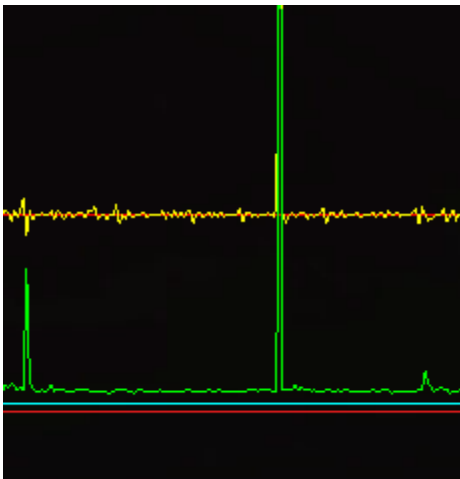

The two red lines denote the limits of playback: the bottom red line is represents a zero baseline, and the top shows how many milliseconds it takes to draw a single frame. The top red line is not always clearly visible as should be under the yellow line. The line spacing at 30 FPS playback therefore represents 33.3 ms, whilst at 60 FPS playback it represents 16.7 ms and at 120 FPS playback, 8.3 ms.

The yellow line shows the time taken for the graphics card to actually draw the frame: if this spikes, it means that the graphics card is reading the movie frames but is unable to write them in time and so the (video) frame is dropped.

The green line refers to the performance/load of the whole server: the CPU, RAM and GPU.

- When spiking between the red lines, it demonstrates an appropriate level of use that the server components can manage.
- If the green line spikes up *above* the top red line once, it means that the performance/load of the server was increased for a split second: this may cause a video frame drop due to the performance/load being too much for the graphics card to draw a frame in time.
- If it is *constantly* spiking up above the top red/yellow lines then your server is not coping with the demand on it, so you may need to reconsider its load.
- If the green line drops or spikes *down* this may be because the performance/load of the server is decreased and movie frame(s) cannot be read. This shows as a movie frame drop, as the frame cannot be rendered/drawn.

The blue line monitors the audio and is only in view if you have audio devices attached and audio resources on the timeline.









See also:







- [Viewing and Previewing Shows](#) <sup>414</sup>
- [User Information / Stats](#) <sup>125</sup>

## Delta Supported Media and File Locations

DeltaServer can use many different types of media to create a show, including many effects and transitions. The supported types and their functions are listed below. Their group locations follow their type names on the C:\ drive (movies are on the E:\ drive because of their size).

Drive locations are set in *Preferences* > [Disk Drive Configuration](#) <sup>(97)</sup>.

File Type	Function
 <a href="#">Movies</a> <sup>(40)</sup>	A sequence of images (e.g. stars_0001.tga, stars_0002.tga) played back at the specified framerate. TGA, 7TH/STH or DPX format files are preferred for performance
 <a href="#">Images</a> <sup>(44)</sup>	Single bitmap images in a variety of formats, up to 16384 × 16384 (graphics card dependent) pixels, including full 8-bit alpha plane in TGA, TIF and PNG images
 <a href="#">Audio</a> <sup>(45)</sup>	Audio files in a variety of formats
 <a href="#">Effects</a> <sup>(49)</sup>	Includes: <b>Fade:</b> Fade the image to black or up from black over specified time. When placed on an audio layer, also fades audio volume. <b>Transparency:</b> Fade the image transparency to the lower layers over time. <b>Dynamic Transparency:</b> You can set the opacity of these from external control by layer or resource name using the LAYERFADE command.
 <a href="#">Geometry</a> <sup>(46)</sup>	Static distortion correction to match projectors to screens (flat, curved or full dome). Morphed distortion to provide fly-in or transition effects. As background layer affects a specified output channel; on a layer, applies effects to only that layer.
 <a href="#">Video Capture</a> <sup>(314)</sup>	Using an optional capture card or USB Web camera, multiple live video sources can be placed on the timeline in exactly the same way as images. Spout input and web pages also appear as capture resources.
 <a href="#">Timing Controls</a> <sup>(293)</sup>	<b>Loop:</b> Restart playing at the start of the timeline. <b>Stop:</b> Stop playing at this point on the timeline. <b>Goto:</b> Jump to a specific frame (or Marker – from Delta 2.7). <b>Comment:</b> Add user notes to the layer. <b>Marker:</b> Named marker, allowing interactive or external control to go to that point. <b>Placeholder:</b> A placeholder reserves a space on the timeline to be allocated to media. <b>GUI Beep:</b> An audible beep on the DeltaGUI PC only. <b>Load Show:</b> Load a different show at this point on the timeline. <b>Sequence:</b> Call a sequence at a point on the timeline. <b>Section:</b> Show a part of the timeline in a user-set colour to highlight it.
 <a href="#">Text</a> <sup>(334)</sup>	The text resource is a simple way of placing custom titling onto a show. The standard text resource can be placed multiple times on the timeline, and the font, size, colour, animation and location specified independently for each. The <b>Timecode</b> text resource shows the timecode only of that timeline. The <b>Movie Timecode</b> text resource (when placed on the same layer as a movie) shows the current filename of the frame-based movie, or the filename and path of a codec movie.
 <a href="#">Serial Events</a> <sup>(46)</sup>	External devices can be serially controlled on a frame accurate basis by placing serial events on the timeline, such as Start Projector or Select Source.

File Type	Function
 <a href="#">Blending</a> <sup>45</sup>	Edge blending to allow overlapped projected images to be blended into one seamless, continuous display surface.
 <a href="#">Colour</a> <sup>47</sup>	Static colour correction to match adjacent projectors to each other.
 <a href="#">Splines</a> <sup>48</sup>	The Spline resource is a user-drawn path over which visual resources on that layer will follow. You can draw the shape of the spline in the Spline editing page.
 <a href="#">Art-Net</a> <sup>48</sup>	Art-Net input and output controls allow interaction with external lighting, smoke or motion systems.
 <a href="#">Container</a> <sup>49</sup>	Containers include a Playlist for simple looping play of media and AV Assembly to allow grouping of media into one set.
 <a href="#">Shader Effects</a> <sup>49</sup>	Types of shaders include Effects, Colours and Transitions, and <a href="#">Notch Effects</a> <sup>402</sup> (with licence) can be added.

Meshes, Show files and Autoalignment all have their own base folders on the same drive (typically C:\).

➤ See also this guide: [Managing Media for Delta Media Servers](#)

## Movies

 These are sequential image frames stored on a fast, hard disk. Supported playback file types include; 7TH (STH), TGA, YUV, A7S, DPX, CIN, SGI. From Delta 2.7 build 7, DPX 2.0HDR is supported.

Codec filetypes (MXF, MOV, MP4, LXF, ASF, WMV, DV, MPEG-PS, MPEG-TS, GXF, FLV, AVI, MKV, WebM, HapQ, 7thHapQS) are supported.

**Note:** With codec movie formats, the audio is in-built and speaker mapping is encoded in the file itself, so Delta audio control available is therefore only volume control (no channel mapping as is possible with separate audio files – see audio files below).

Since all codec playback in Delta is CPU-based, this typically allows only 1-2 movies at HD 60p or equivalent resolutions. For anything more, codec movies should be converted to image sequences using [Distributed File Manager](#).

Supported file types for recording (also known as carving or slicing) are JPG, JPEG2000, BMP, TIF and PNG, in addition to all movie formats listed above.

Individual movies are stored in separate folders under the **MOVIES** folder like this:



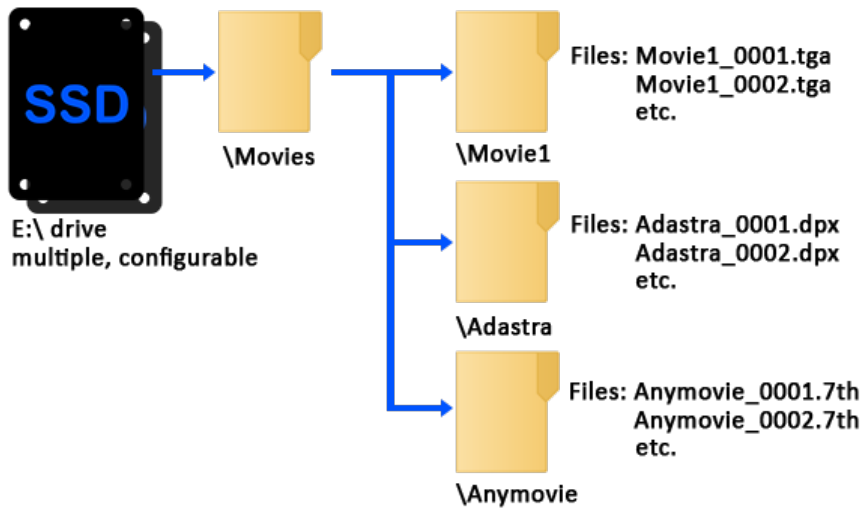

Note that the movie name presented in the DeltaGUI is the name of the First file found, minus the frame count (e.g. Movie1\_0001, Movie1\_0002.tga, Movie1\_0003 will be shown as 'Movie1\_' in the resources area (note the underscore).

## Movie thumbnails

By default, DeltaServer creates a thumbnail of the first frame of every movie whenever the Resource Pool is refreshed, and stores these in C:\7thSense\web\data\thumbnails. Thumbnails are used as resource pool icons and on the timeline to help identify assets.

From Delta 2.7 build 7, movie files beginning other than frame numbered ~00 will show a thumbnail of the first frame found, and display the number of the first frame, in the file Information shown on timeline resource hover, and dialogs where a Start Frame is set.

*Example:* Movie starts with frame 'name\_0140.tga'. Thumbnail of frame 140 is shown and in dialogs, this additional information:

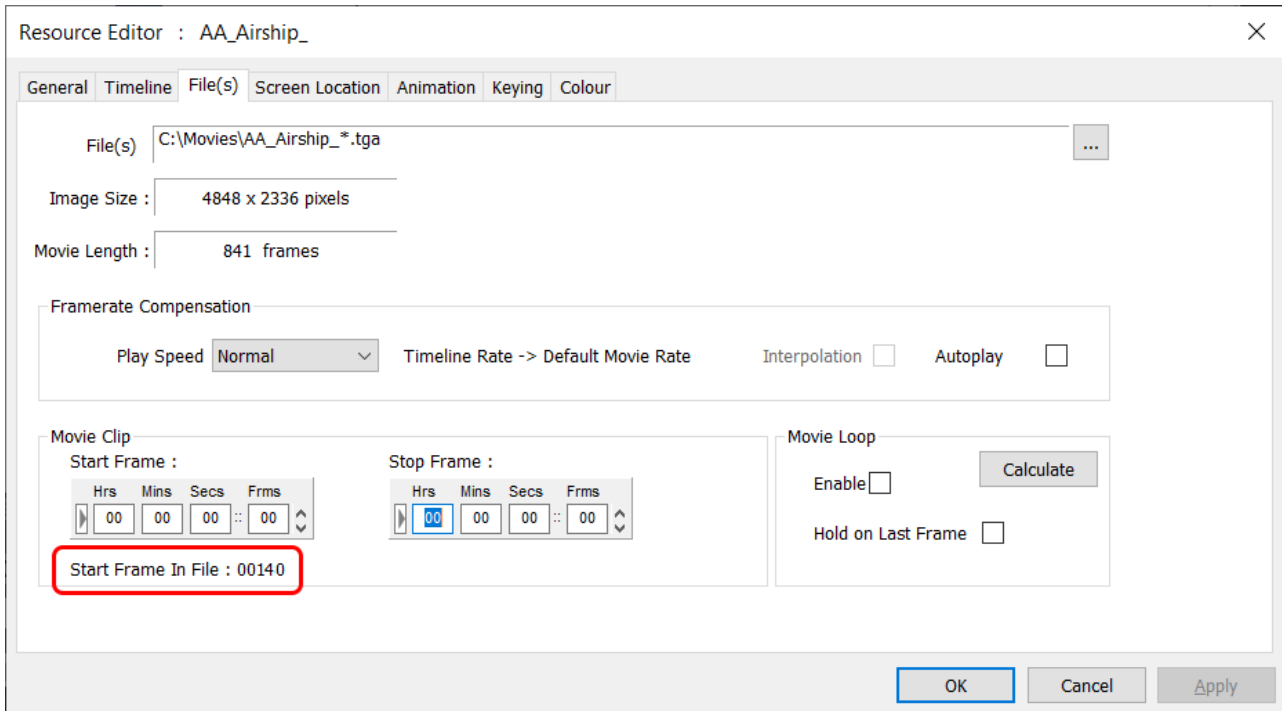

**Note:** 'Start Frame 00' becomes relative, so to stop at stop frame of 50 would mean frame filename ending 'name\_0190.tga'.

## Notes on Movie File Sequences

- The movie filenames require a fixed number of digits for the framecount, preceded by an underscore, so:

Movie\_0998, Movie\_0999, Movie\_1000 is acceptable

Movie\_998, Movie\_999, Movie\_1000 is not suitable.

- For best playback performance of uncompressed media, use TGA, DPX sequences or convert image sequences to one of the 7TH file format using the supplied DFM utility.**

- Best performance is achieved when the Movies are served from one drive or RAID set, and all other content is served from a separate drive.

Configure this in *Preferences > Disk Drives* in the DeltaGUI.

- TGA, SGI, CINEon, DPX or YUV single file per frame format require Solid State drives (SSD) to play these movies in realtime.
- TGA single file per frame movies can also have an alpha plane – this will require fast disks. Uncompressed or RLE compressed TGA files only
- DPX: .dpx formats have been more broadly supported:
  - 8-bit (4:4:4)
  - 10-bit (YUV and 4:4:4)
  - 12-bit (4:4:4)

- full support of little- and big-endian
- filled and packed types are both supported
- 8-bit RGBA: supported from Delta 2.7
- 10-bit RGBA: supported from Delta 2.7
- V2.0HDR is supported from Delta 2.7 build 7.

## Encrypting Movies

Movies can be encrypted using 7thSense Distributed File Manager (DFM) with a valid date range and venue code which is locked to a single or multiple USB keys to protect content from being used elsewhere.

➤ See: [Managing Media for Delta Servers](#)

## Movie Formats

**Note:** All outputs from a single server must be configured to the same video format and refresh rate. See also [Timing Configuration](#)<sup>99</sup>.

Format	Image Quality	Hardware Requirement
7th	Medium	6:1 compression, lowest hardware requirements
7th 420	Good	[4:2:0] This is 2:1 compression, and can be the best compromise between quality and performance High performance disks required
7th 420 Z	Good	[4:2:0] 2:1 compression with lossless compression. High performance CPU and disks required
7th 422	Excellent	[4:2:2] This is 1.5:1 compression, and improves on the 420 format for quality. High performance disks required
7th 422 Z	Excellent	[4:2:2] 1.5:1 compression with lossless compression. High performance CPU and disks required
7th 422 10 bit	Excellent	[4:2:2] Added colour depth. This is 1.5:1 compression, and improves on the 420 format for quality. High performance disks required
7th RGB Z	Perfect	Lossless compression. High performance CPU and disks required
7th 444	Perfect	[4:4:4] No compression. 8-, 10- or 12-bit High performance disks required
7th 444A	Perfect	[4:4:4:4] No compression

Format	Image Quality	Hardware Requirement
		High performance disks required Alpha Layer
7th HapQ (YCoCgS)	Good to Excellent	3:1 compression
YUV 422	Excellent	[4:2:2] Raw, single 422 frames in 2VUY [UYVY] 8-bit format. SSD disks required
DPX	Perfect	No compression, can be 8, 10 or 12-bit SSD disks required
CIN	Perfect	No compression, can be 8 or 10-bit SSD disks required
A7S	Perfect	No compression (can be losslessly compressed), can be 8 or 10-bit, RGB or 422 colour space. SSD disks required
TGA	Perfect	Uncompressed or RLE compression, 24-bit (can have 8-bit alpha plane) or 16-bit (optional 1-bit alpha plane). Single file per frame TGA files are supported (will require SSD disks).
SGI	Perfect	No compression, 8-bit SSD disks required

**Note** that TGA, A7S, CIN, DPX and SGI sequences can be used as movies with a system using SSD and NVMe disks.

BMP, TIF, JPG2000 and JPG are not optimised for real-time playback, but can be used as a source movie for recording out to another format.

## Images

 Images can be JPG, JPEG2000, BMP, DPX, DPX 2.0HDR, OpenEXR SDR and HDR, PSD, TIF, TGA, PNG, GIF or A7S format. These are stored in the IMAGES folder, and can be grouped into subfolders as required.

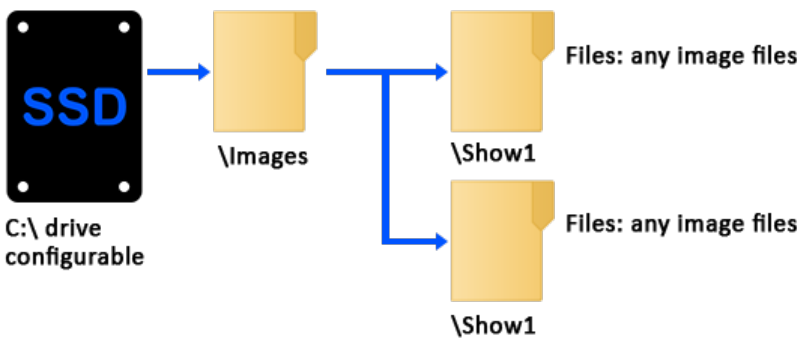

- Images can be up to 16384 × 16384 pixels in size depending on graphics card capabilities.

- Images larger than this will be scaled down to 16384 × 16384 pixels.

The alpha channel is available in TGA, TIF (LZW and normal) and PNG file types.

## Audio

---



Audio files are single sound files of WAV, MP3, MP2, AIFF type. These are stored in the AUDIO folder, and can be grouped into subfolders as required.

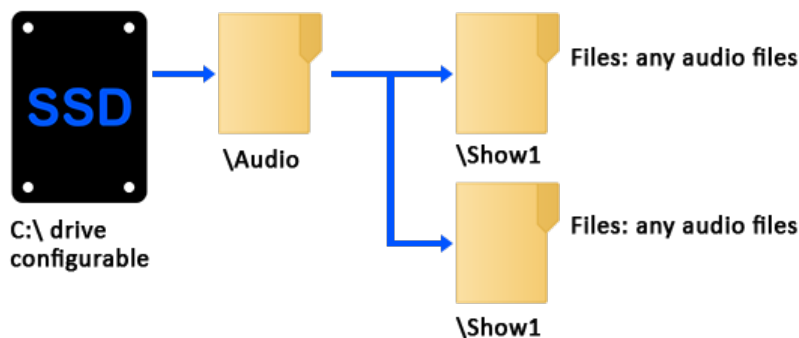

Surround sound audio can be created using multi-channel WAV (up to 32 channels) or individual mono WAVs (preferred), which can be directed to the appropriate output within Delta.

- [Resource Editor: Audio Files](#) <sup>312</sup>

## Effects

---



Default effects include dynamic effects accessible to External Controls, and timeline effects (transparency, fade, alpha) and a transform animator (movement effects). Other custom effects can be added.

- [Timeline Effects](#) <sup>396</sup>
- see also: [Shader Effects](#) <sup>49</sup>

## Edge Blending

---



Preset blending files have the extension 7BL. These are created and stored using the DeltaGUI. These are stored in the BLENDING folder, and can be grouped into subfolders as required. Blends (if any) are also stored in each show file you save.

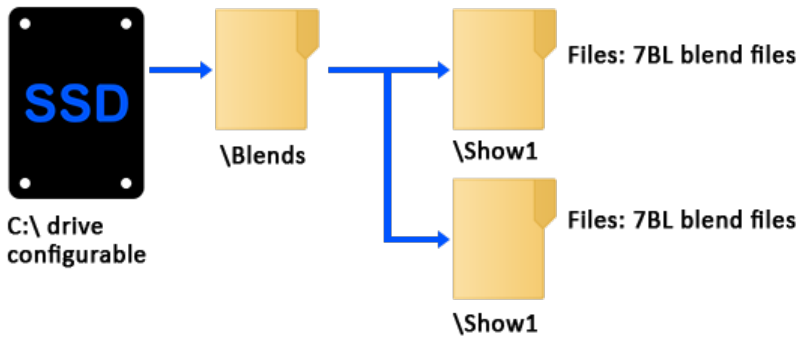

➤ [Display Configuration: Blending](#) <sup>150</sup>

## Geometry Correction / Warp

 Preset warp / geometry files have the extension 7GM. These are created and stored using the DeltaGUI. These are stored in the GEOMETRY folder, and can be grouped into subfolders as required. Geometry (if any) is also stored in each show file you save.

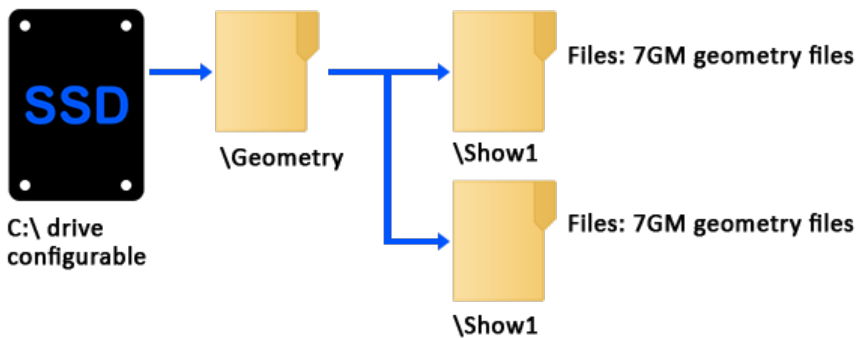

➤ [Geometry](#) <sup>353</sup>

## Serial Events

 Serial Event files have the extension 7SE. These are shown using the DeltaGUI. These are stored in the SERIALEVENTS folder, and can be grouped into subfolders as required, although these groups do not show up in the DeltaGUI. Serial Event controls (if any) are also stored in each show file you save.

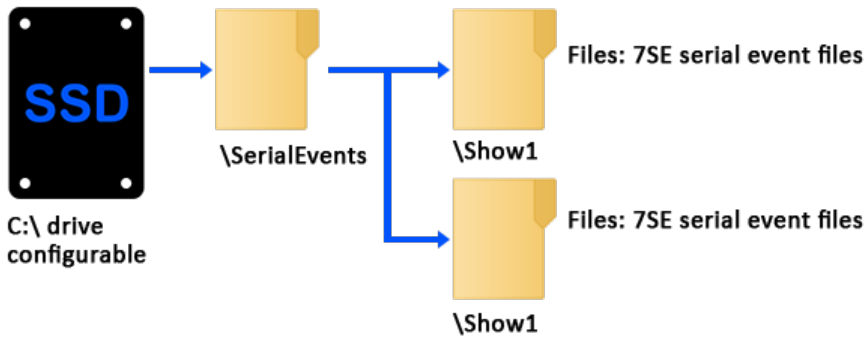

Com ports are configured in the Preferences dialog, see the relevant section below.

## Notes

External Control is a built-in serial event device. You can output any string on the external control com port or Telnet, e.g. to notify the controller that a specific point on the timeline has been reached.

If you create a file named 'External Control.7SE' in the SERIALEVENTS folder, the contents of this will be available when adding an external control event to the timeline. This allows standard external control commands to be available. The format of this file is the same as other serial event 7SE files.

Serial Events can be set to repeat for a number of counts and at a set frame interval.

## Telnet Serial Events

A Serial Event can be output to a specific IP Address and port.

➤ [Serial Events](#) <sup>373</sup>

## Colour Correction



Preset colour files have the extension 7CO. These are created and stored using the DeltaGUI.

These are stored in the COLOUR folder, and can be grouped into subfolders as required. Colour controls (if any) are also stored in each show file you save.

Colour lookup table (LUT) files are also held here, in .CUBE file format.

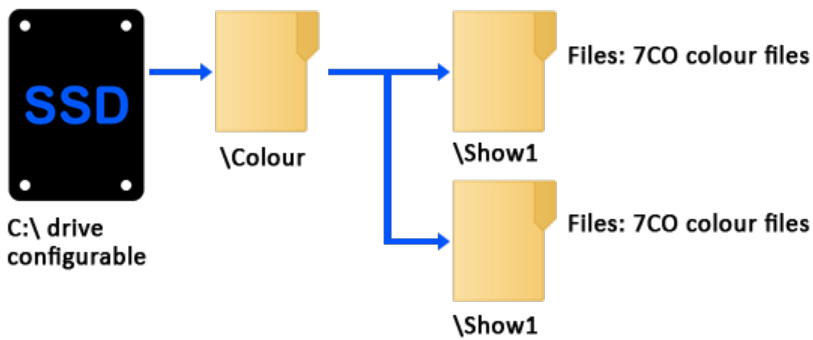

- [Display Configuration: Colour Balancing and Convergence](#) <sup>(153)</sup>
- [Colour LUTs](#) <sup>(375)</sup>

## Splines

---

 A motion path for visual resources to follow can be created in the Splines menu. This path can be saved to disk for use in other shows. Spline files have the extension 7BZ. These are shown using the DeltaGUI. These are stored in the SPLINES folder, and can be grouped into subfolders as required, although these groups do not show up in the DeltaGUI. Spline controls (if any) are also stored in each show file you save.

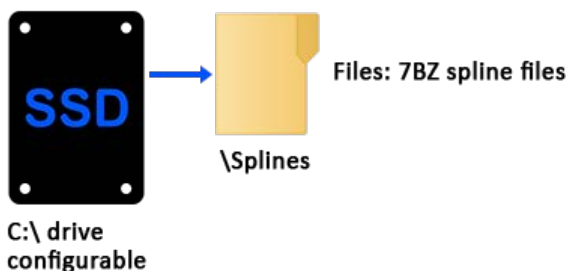

- [Splines](#) <sup>(377)</sup>

## Art-Net

---

 An input or output Art-Net control with preset channels and values can be created in the Art-Net and DMX Editor. This control can be saved to disk for use in other shows. Art-Net files have the extension 7AN. These are shown using the DeltaGUI. These are stored in the ARTNET folder, and can be grouped into subfolders as required, although these groups do not show up in the DeltaGUI. Art-Net controls (if any) are also stored in each show file you save.



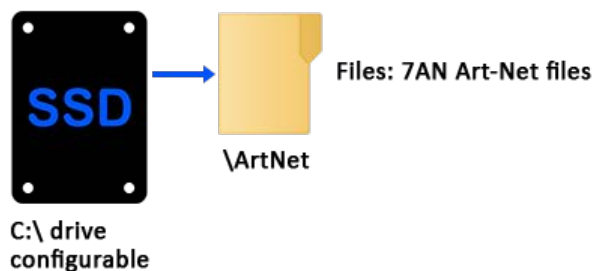

➤ [Art-Net and DMX](#) <sup>(379)</sup>

## Containers

 Playlists or AV Assemblies can be created interactively in the DeltaGUI and saved out as Presets to the Preset folder. Container controls (if any) are also stored in each show file you save.

➤ [Playlist / AV Assembly](#) <sup>(387)</sup>

## Shader Effects

 Shader Effects allow users to create and control the behaviour of the way all media assets are rendered, through Delta by writing OpenGL fragment and vertex shaders. Effects can be controlled either through the DeltaGUI or via external control over TCP, UDP or HTTP. Shader Effects resources are in C:\Effects.

File types depend on the effects used, but are typically .frag and .xml. These are stored in the Effects folder, and can be grouped into subfolders as required. One such folder could be \Notch for those specific effects.

Licensed Notch users with a Notch Playback key, can import DFXDLL files for playback with exposed parameters. Notch Effects must be saved to C:\Effects\Notch.

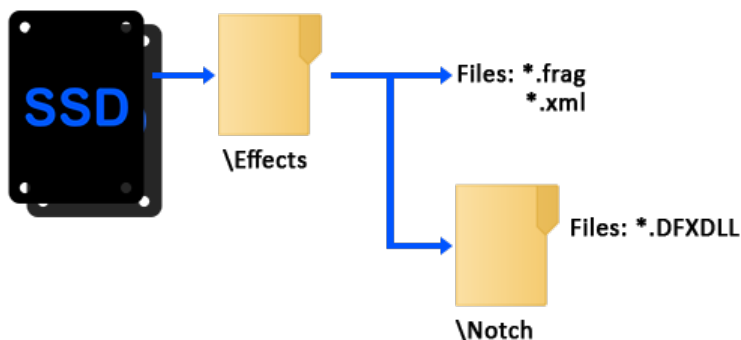

➤ [Shader Effects](#) <sup>(397)</sup>

➤ [Using Notch Effects](#) <sup>(402)</sup>

## Sequences

---

Sequences are user-editable macros which can be called at any time from DeltaGUI or via external control. They are useful for assembling a list of commonly-used playback controls. Timeline control sequences are stored in individual **XML** files in C:\Sequences. Subfolders can be used by prefacing the filename with a new folder name when creating the sequence.

**Note:** the full list of sequence code supported is accessed from the *Sequence Editor > Help* button.

➤ [Sequences](#) <sup>354</sup>

## Part 2: DeltaGUI Software

## Part 2: DeltaGUI Software

---



**Well worth it:** learn some of the many shortcut keys for DeltaServer, DeltaGUI and Playback Window:

➤ [Appendix E: Shortcut Keys](#) <sup>453</sup>

### For Server Control

DeltaGUI is above all the server coordinator, connecting to and communicating with all Delta servers on the network. It is not required to play a show, since DeltaServer itself can be controlled from many external control inputs, as well as a browser-based preview facility and a customisable web-based control interface for interacting dynamically with shows.

### For Display Configuration

The Delta Graphical User Interface is the editing heart of the system. Here is where you set up your display or projection theatre for all your projection, screens, sound and effects peripherals. Alignment, colour convergence, warps, blends and meshes are all applied here.

These adjustments and calibration parameters for flat and curved screens, domes and mappings, can then be applied to any media show for perfect, immediate delivery.

Alignment and blending for each mode: Flat plane, Dome and Mesh are described in more detail in separate guides. To optimise performance, movie media may also require 'carving', i.e. each frame cropped down to only the area required for a particular channel.

### As Show Editor

DeltaGUI is also the resource editor: layering, sizing and manipulating media to create complex shows on multiple timelines. It coordinates and synchronises all events, including live sources. Modified resources, such as applied geometry, blends, colours, captures, playlists and animations, can be saved and reused, and there is a macro language for creating repeat-use sequences.

## Server Connections

Individual Delta servers are assigned to a Group in the server Preferences menu:

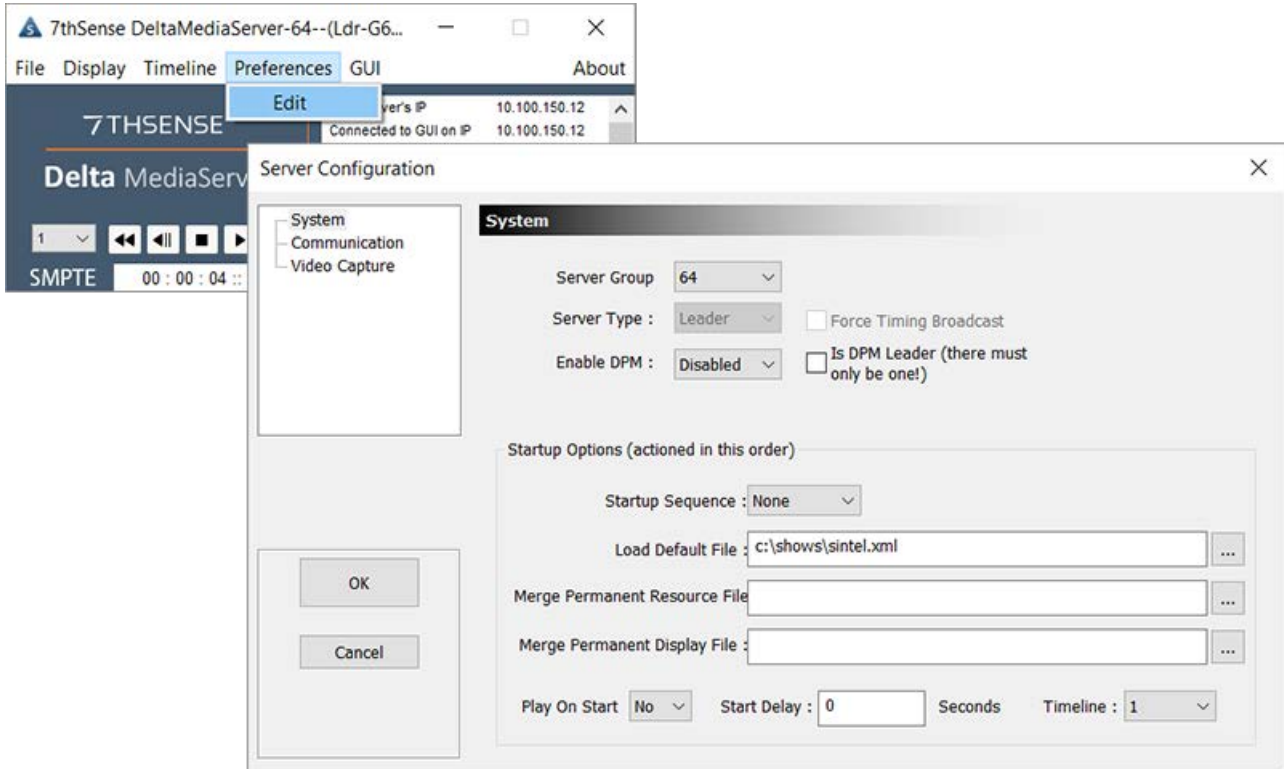

DeltaGUI tries to connect automatically to all servers in the network, but individual server groups can be blocked. This is done in the *Configure > Preferences > Communication* dialog to [Block Groups] so that DeltaGUI will refuse connections from certain groups.

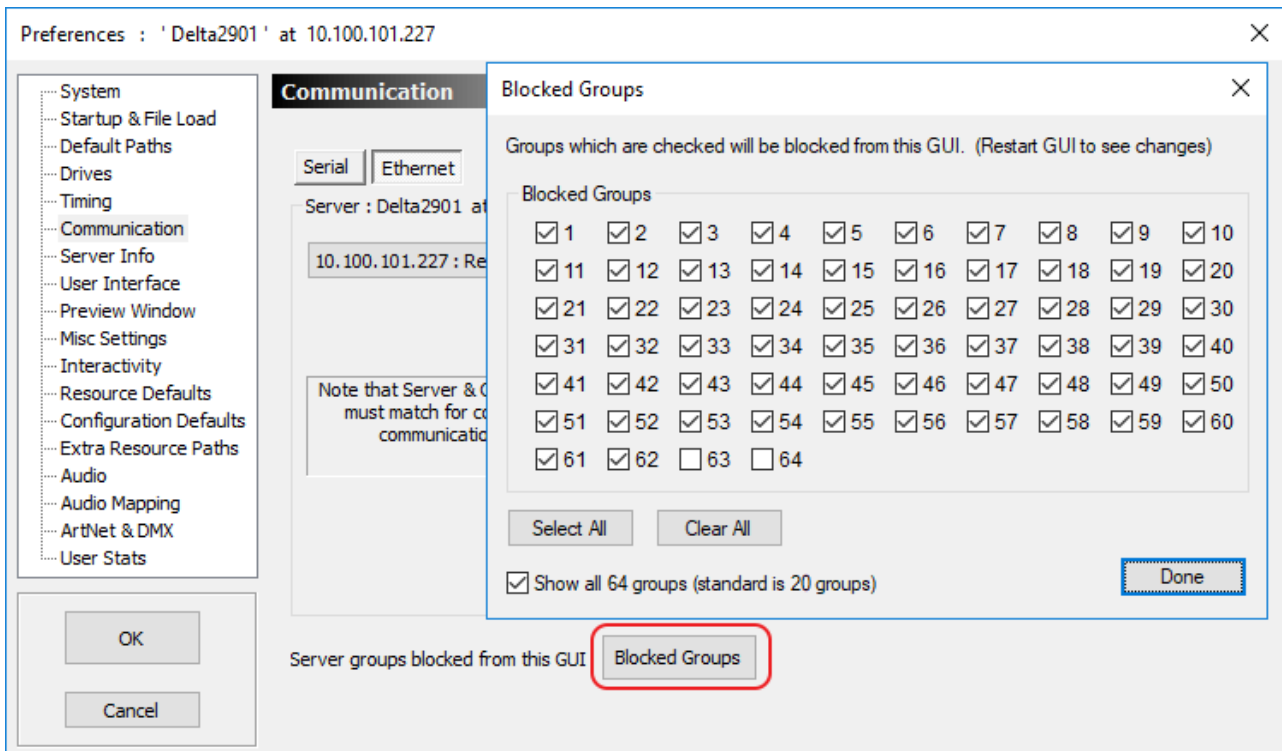

## Connect to a specific group on opening

From Delta 2.7, if, when you start DeltaGUI up, you know what group you want to address, hold Shift down as you open DeltaGUI. This will instead offer a selection dialog:

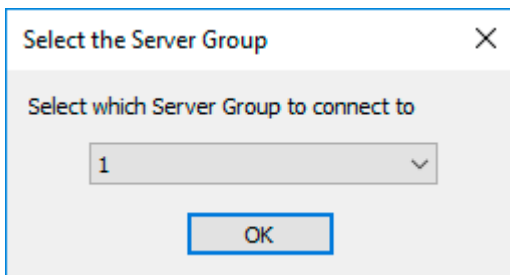

The drop-down list will show all 64 potential groups, and overrides any blocked server groups. Select the required group and DeltaGUI will open connected to that group. The *Preferences > Communication > Blocked Groups* option will be greyed out.

➤ (See also [Communication Configuration](#) <sup>(102)</sup>.)

## View connected servers

You can view what servers are attempting to connect to this instance of DeltaGUI, by choosing the *Help > Server Connections* option from the DeltaGUI menu.

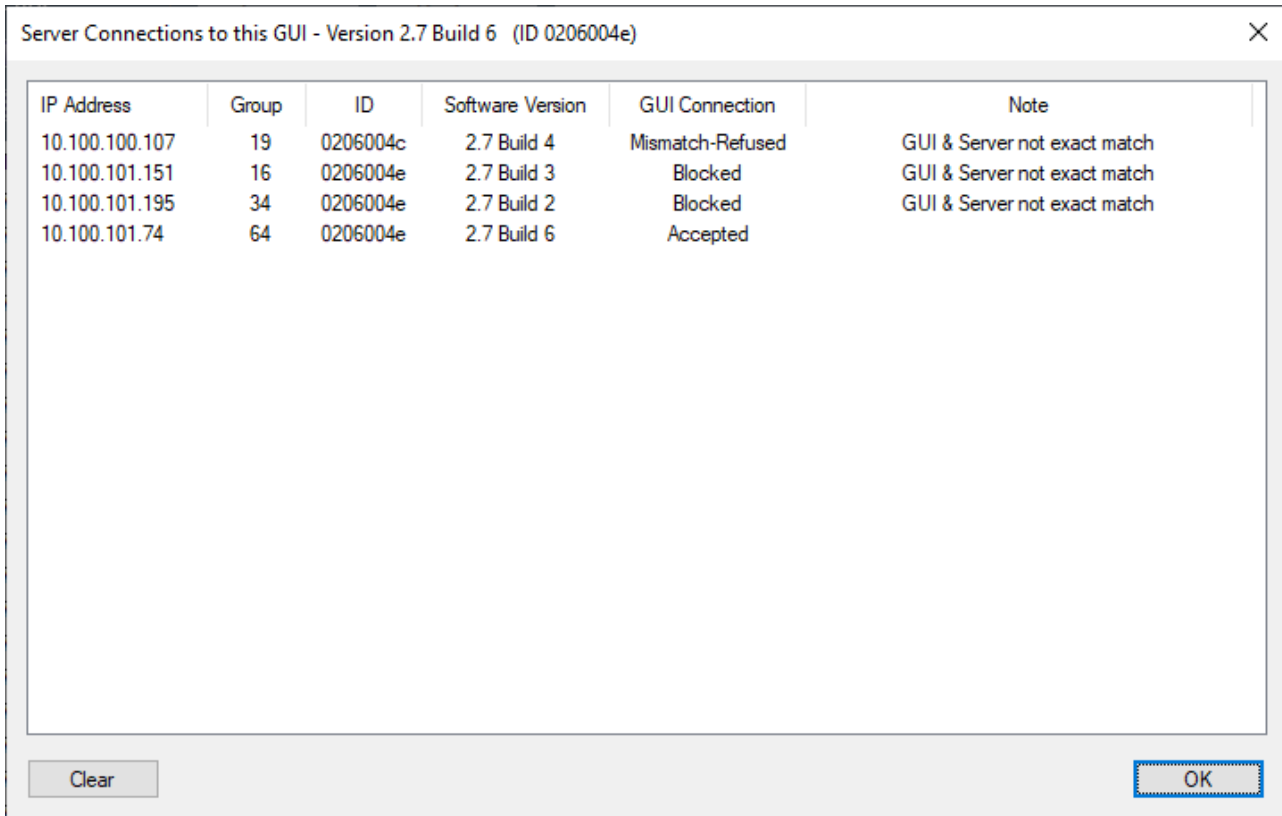

**This example dialog shows 5 servers:**

Three have **mismatched** server versions, but the server at 10.100.101.74 has been accepted as not blocked and is the correct version.

You can clear this list by pressing the Clear button – note that the list will now only show servers which attempt to connect from then on – previously connected servers will not show up.

Shown below is a graphical view of all blocked or active groups, with attached or blocked servers and the reason for blocking (blocked or mismatched versions):

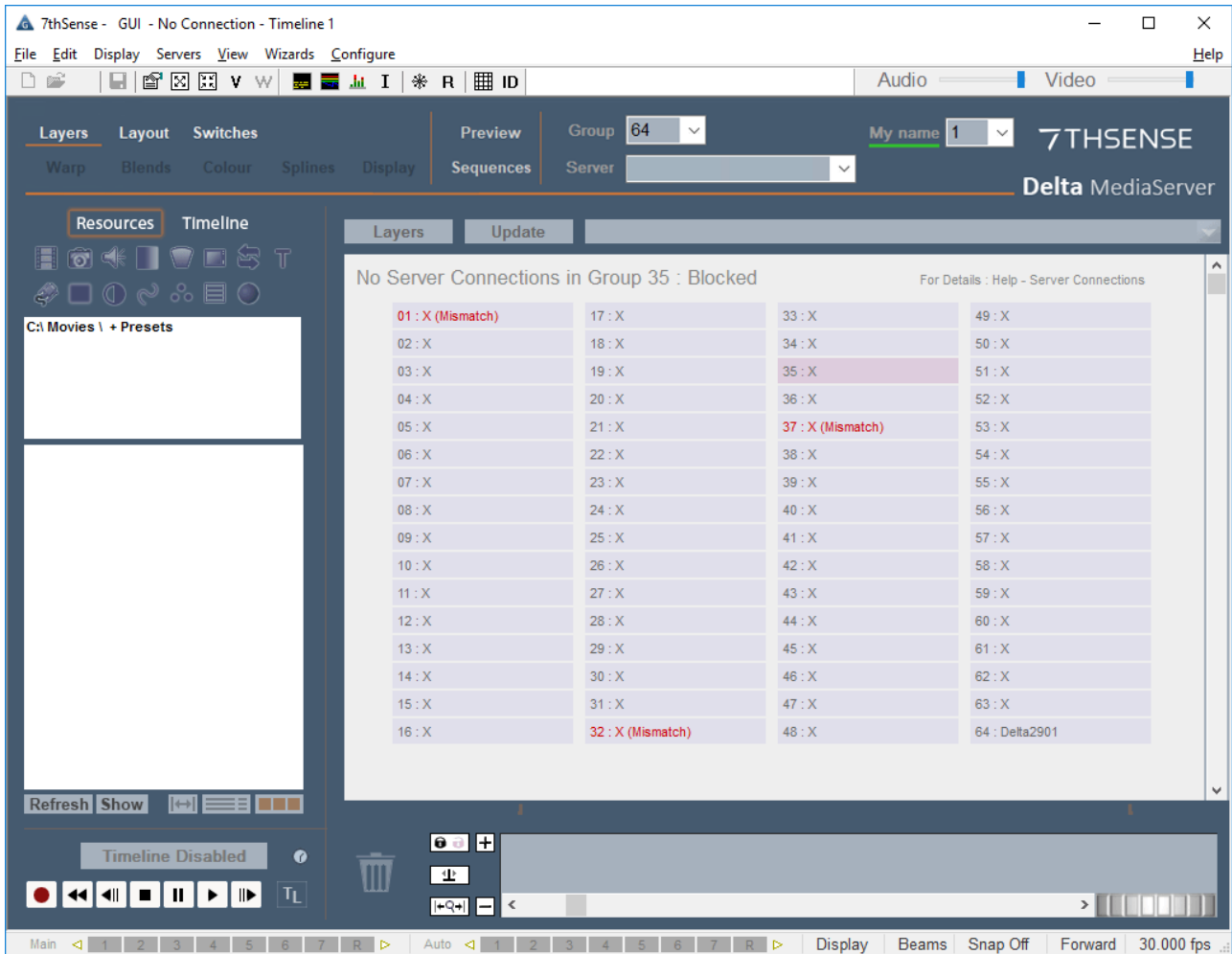

Clicking on any of the groups will select that group in DeltaGUI.

### If 'Group' flashes red

If you are using a group of servers, there should always be a Leader server with the others set to Follower.

If the Group flashes red (as below), there are other servers attached to the group which may not actually belong to it (i.e. not in a Leader/Follower configuration): individual and groups of servers should always be given their own group in the server software.

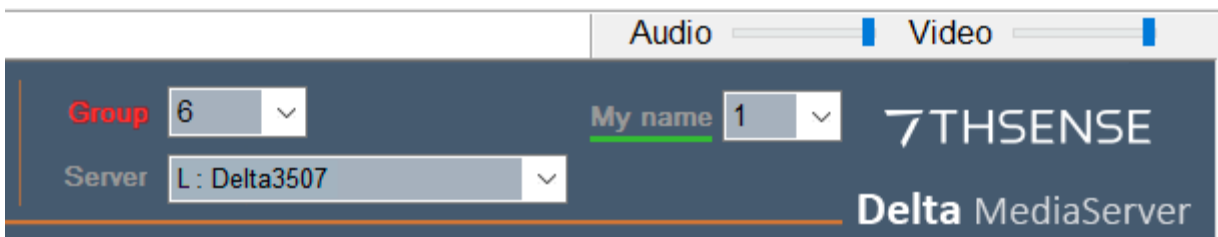



## Multi-Rack Control

The DeltaGUI is inherently multi-rack aware, and will find all Delta servers on the network if they are not currently attached to a DeltaGUI instance.

You can choose to place servers into a Group (1-64), and then set one server to Leader, the others to Followers. The Leader server will then broadcast timing information to the Followers over Ethernet.

You view a specific server by choosing its group, then the server by name. DeltaGUI therefore shows one server's timeline at a time.

## Server List Dialog

To view all servers, choose *Servers > View Server List* from the main menu. This dialog offers a summary of the current status of all servers and all timelines available.

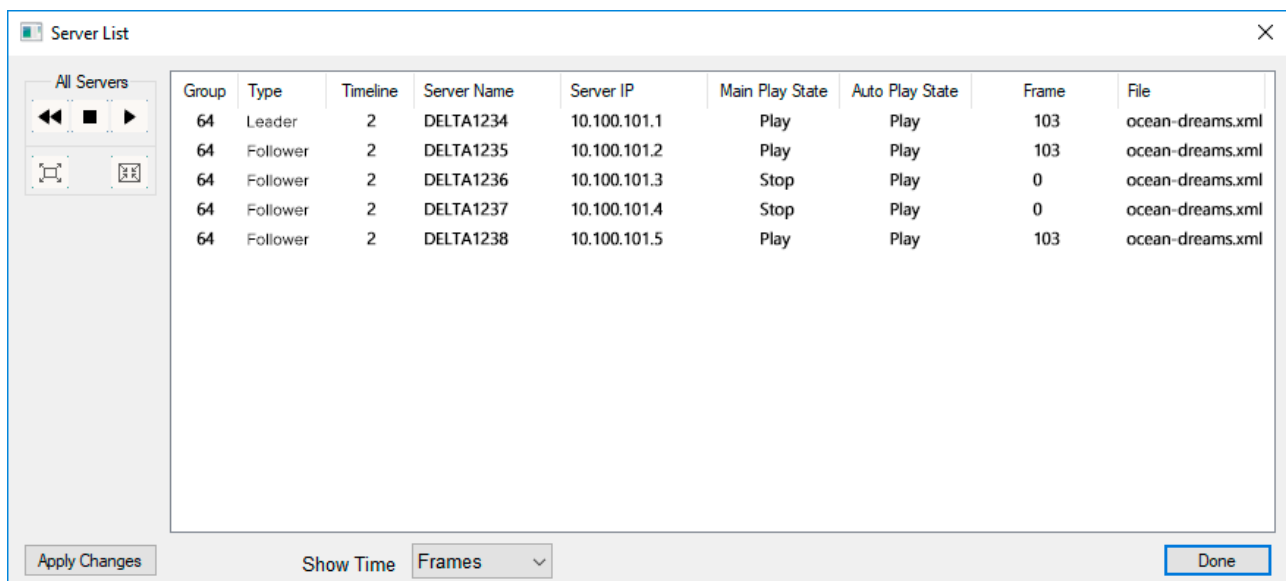

You can start, rewind or stop all servers and set them all to fullscreen or windowed.

## Copy Timeline

This action copies **all timelines** and/or **display configurations** from the show loaded on the selected server into the currently-loaded show file on all selected destination servers.

As a convenient shortcut, the menu item *Server > Copy Timeline* allows you to propagate the show or configuration from the currently selected server to either the current group or all servers.

**Note** that the exact resources from one server are sent to the others, so if resources are kept in different paths, or are missing, the show will not be constructed properly.

The current show is overwritten with the new show.

For all modes below, you can choose to copy the following:

#### **Timeline**

Copy the non-background timeline resources only.

#### **Display Mode and Canvas**

Copy the canvas dimensions, display mode (Flat / Stereo etc.).

#### **Channel Configuration**

Copy all channel configuration as well.

#### **Mesh**

For Mesh Mode, copy mesh configuration.

#### **Include Background**

For multi-server systems, display alignment geometry and blending may be placed on the background and Copy timeline would normally overwrite these with the current server's timeline. If you uncheck the 'Include Background' checkbox, it will copy all layers except the background, preserving server-specific background resources.

**Single**

Copy from the chosen server to a single server selected in the drop-down list.

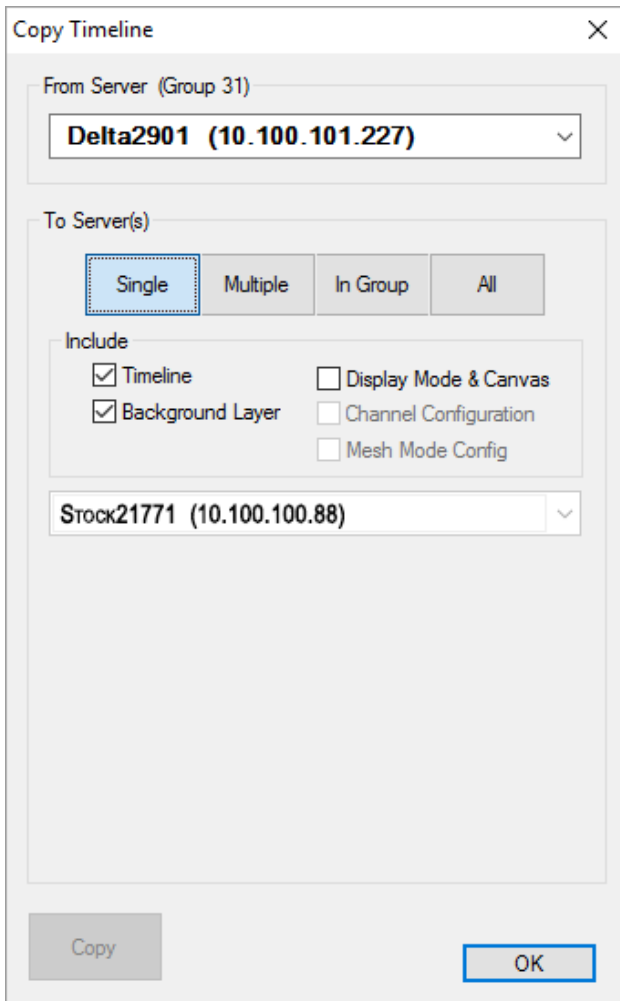

**Multiple**

Copy from the chosen server to a single server selected in the drop-down list.

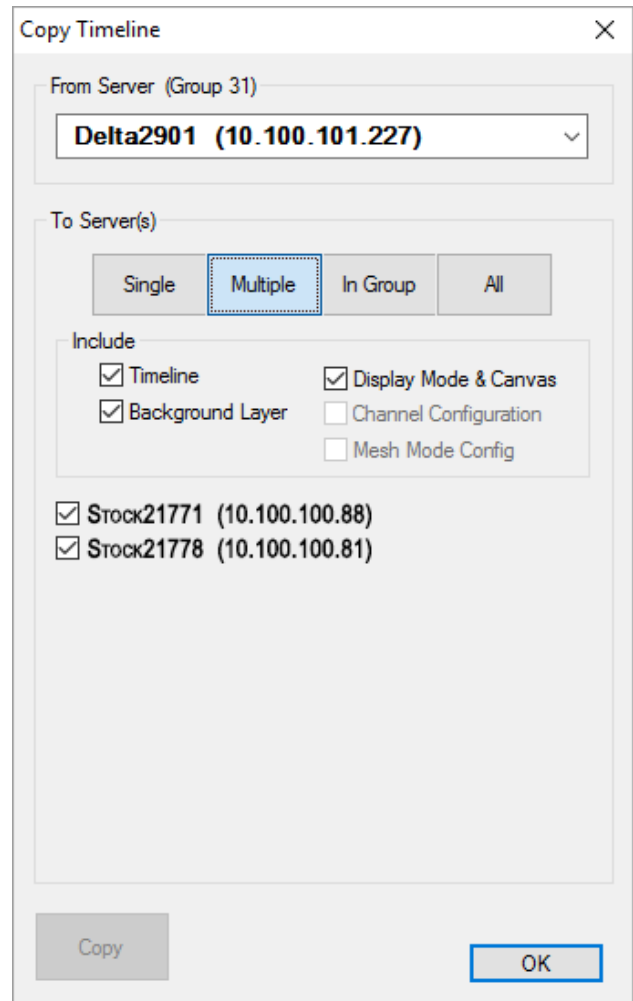

**Group**

Copy from the chosen server to all servers in the selected group.

The 'Copy Timeline' dialog box is titled 'Copy Timeline' with a close button (X) in the top right corner. It features a 'From Server (Group 31)' section with a dropdown menu showing 'Delta2901 (10.100.101.227)'. Below this is a 'To Server(s)' section with four buttons: 'Single', 'Multiple', 'In Group', and 'All'. The 'In Group' button is highlighted with a blue border. Underneath is an 'Include' section with six checkboxes: 'Timeline' (checked), 'Background Layer' (checked), 'Display Mode & Canvas' (unchecked), 'Channel Configuration' (unchecked), and 'Mesh Mode Config' (unchecked). At the bottom left, there is a 'Group' dropdown menu showing '33'. At the bottom right, there are 'Copy' and 'OK' buttons.

**All**

Copy from the chosen server to all servers in all groups.

The 'Copy Timeline' dialog box is titled 'Copy Timeline' with a close button (X) in the top right corner. It features a 'From Server (Group 31)' section with a dropdown menu showing 'Delta2901 (10.100.101.227)'. Below this is a 'To Server(s)' section with four buttons: 'Single', 'Multiple', 'In Group', and 'All'. The 'All' button is highlighted with a blue border. Underneath is an 'Include' section with six checkboxes: 'Timeline' (checked), 'Background Layer' (checked), 'Display Mode & Canvas' (unchecked), 'Channel Configuration' (unchecked), and 'Mesh Mode Config' (unchecked). At the bottom right, there are 'Copy' and 'OK' buttons.

## User Interface

When you interact with DeltaGUI, you are in fact changing the media live on the server and you can see the changes immediately in the Playback Window, also when you save a Delta show, it defaults to saving to the server PC, not the DeltaGUI PC.

In the example below, **Layers** editing is selected from the Workspace menu. [Click the labels to find out more.]

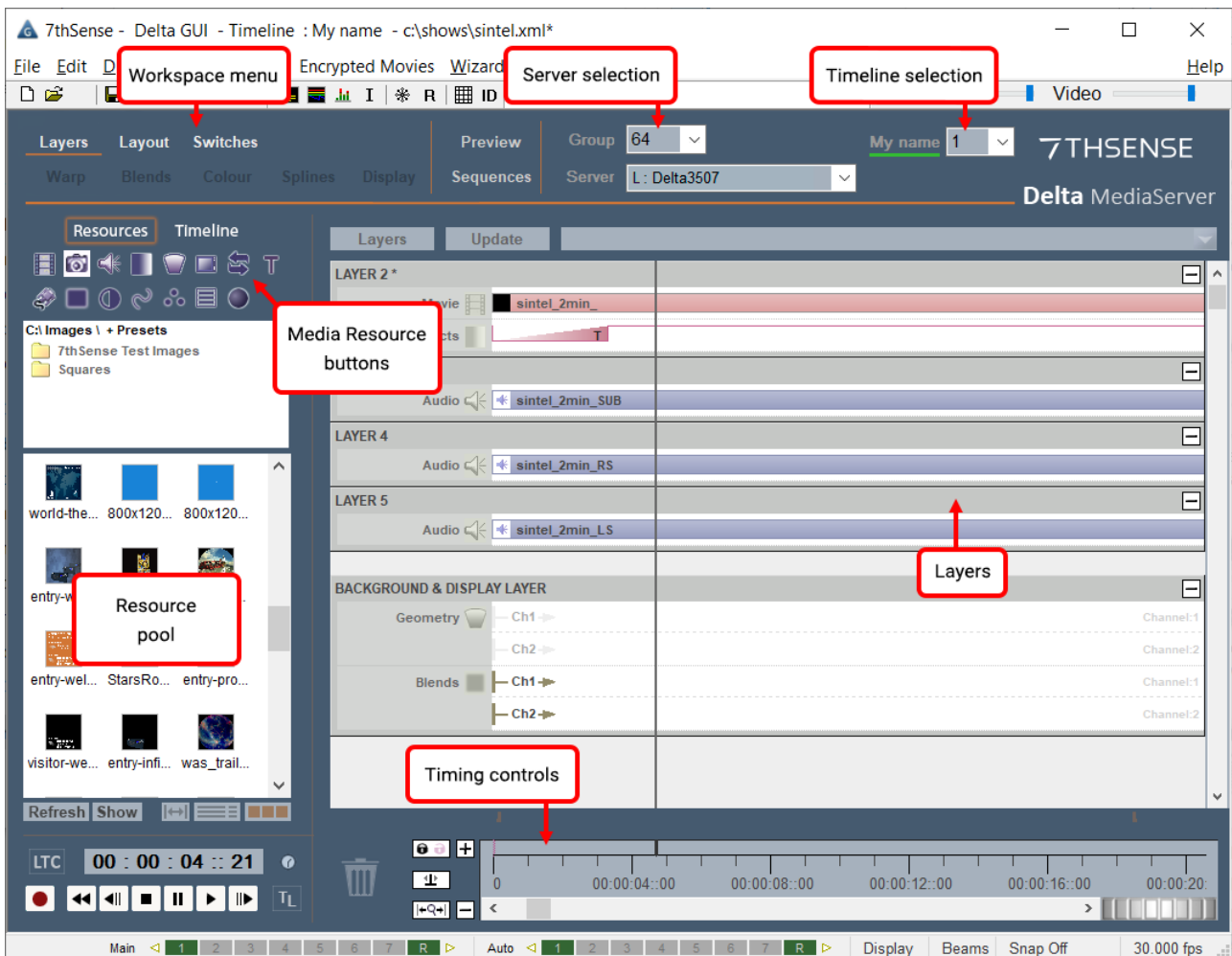

## Main Menu

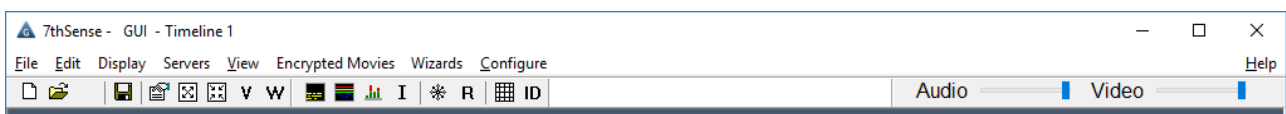

## File

### New (Ctrl+N)

show the File New dialog, which offers clearing the timeline resources from the selected server, all servers in the current group, or all servers attached to the DeltaGUI. You can also optionally reset display configuration to flatplane and clear background resources, and optionally stop persistent sequences from running.

### Open (Ctrl+O)

open a show file that is stored on the server. Note that non-persistent sequences will be stopped.

When saving shows, they must not be running.

### Save (Ctrl+S)

save the current show file to the selected server.

**There is no dialog box for this: if the show xml file is previously unsaved, it will be saved as Default.xml and overwrite any show previously saved to this name.**

(Default.xml is not the same 'default' as the default startup show file: see Save As below.)

If previously named, it will be saved with the same name with which it was opened.

### Save As

prompt for a filename, then save a show file to the selected server. The dialog box allows a show to be allocated as your default startup file (see also [Startup and File Load Configuration](#)<sup>(95)</sup>).

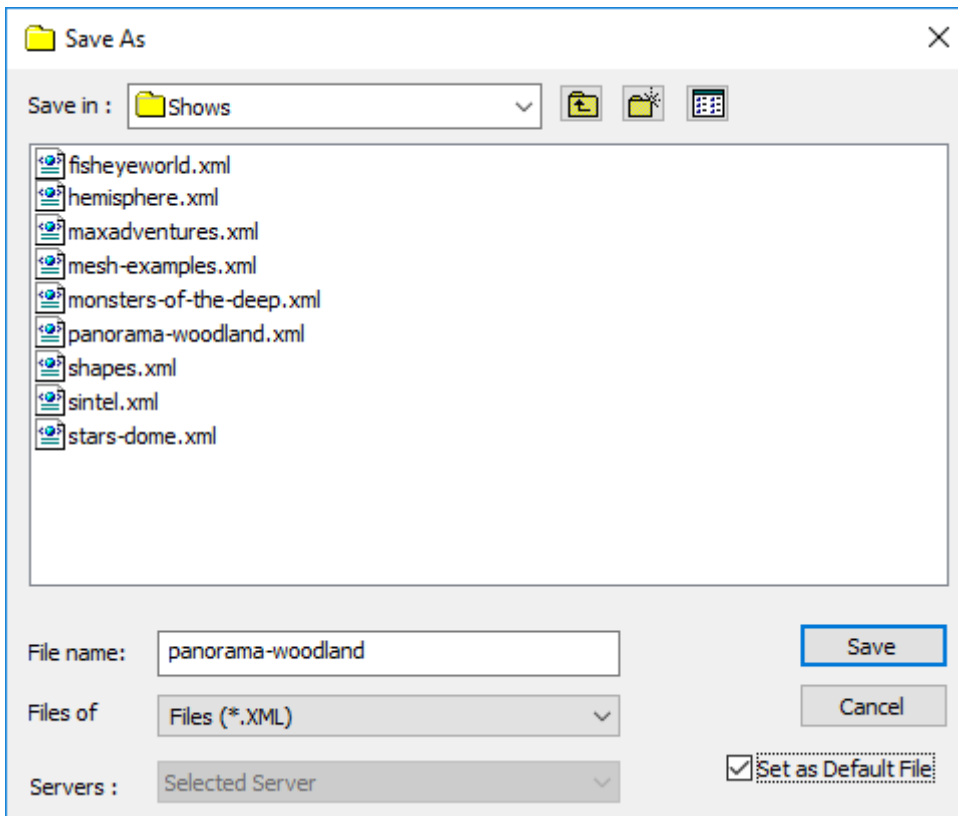

### Merge

open a show file that is stored on the server, and merge it with the current timeline contents.

### Open Locally

open a show file that is stored on the DeltaGUI PC. Note that a subsequent File Save will save on the server.

### Save As Locally

prompt for a filename on the DeltaGUI PC, and save the current show file to the DeltaGUI PC.

### Save All As Locally

prompt for a filename, then save shows from all servers in the current group into separate folders under the chosen folder.

For example, with 2 servers in the group, choosing C:\backups\myfile4.xml as a save file will create file/folders like this:

C:\backups\MYSERVERNAME1\_192.168.1.99\myfile4.xml

C:\backups\MYSERVERNAME2\_192.168.1.111\myfile4.xml

In this way, even with the same filename, any differences on each server are maintained in their own folders.

### Open All

shows the File Open dialog, where you can choose whether to load a show with this name on

the selected group or all servers attached to the server. Note that if the file does not exist, no changes will be made to that server.

**Merge All**

same as the Open All dialog, but resources will be merged with the existing timeline contents on the group or all servers.

**Save All**

shows the Save All dialog, where you can choose to save on the selected group or all attached servers. You can also optionally stop persistent sequences from running.

**Save All As**

same as the Save All dialog, where you can choose to save with the same name to the selected group or all attached servers.

**Note** that on all of: File Open, Save As, Open All and Save All As, you can also choose to set the named show file as the Default File so that this file will load when the server is next booted.

**About Merging**

When one file is open, another can be opened to merge with it. Resources are merged according to their Timeline and Layer. Timelines that are inactive in the first file will remain inactive, though populated by resources from a merged file. Use Ctrl+T to figure timeline activity.

**Edit**

Items on this menu are universal shortcut keys for use when editing within the timeline area (Copy, Paste, Undo etc.). Selection is by rubber-banding / marquee of items, and Copy selection to the clipboard.

**Paste At... (Ctrl+B)**

This control has a dialog, which in 'Basic' mode allows pasting in relation to Mouse (enter a time position), or Current (timeline cursor position).

Expand the dialog with the 'Advanced' button to select a time position in relation to a timeline Marker. This also allows for repeated pasting at set intervals:



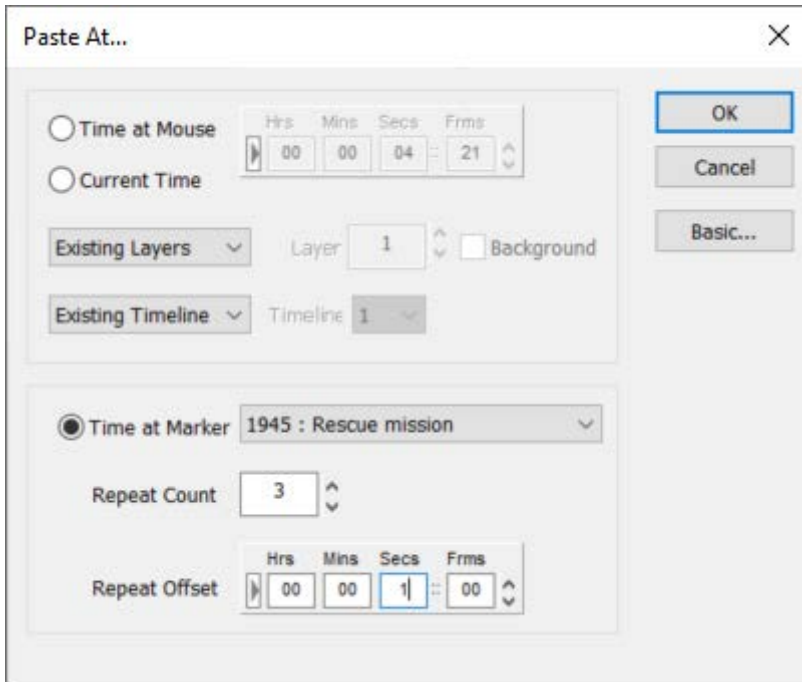

In this example, three repeats at 1-second intervals (shown above) introduce a chime sound starting from the timeline marker selected:

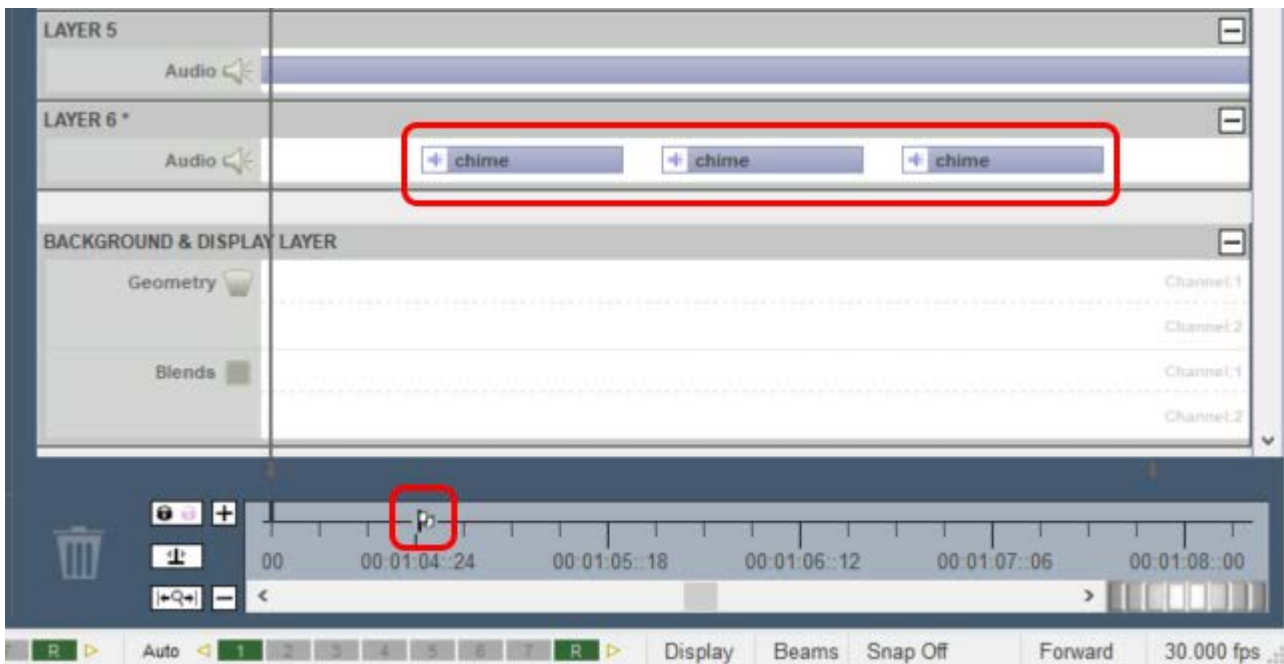

## Display

### Windowed / Fullscreen

displays the Server Playback window in restored size or full screen (the same as pressing F directly in the playback window).

**Reserve Mode (Ctrl+R)**

fade from active timeline to the reserve timeline, or back to the selected timeline. Set the fade time in *Preferences > Misc Settings*.

**Apply Show Mode**

in one operation, configure the server to be ready for an audience. Selecting this option applies the following immediately:

Playback goes **full screen**

Graph, Playback Statistics and Grid are turned **off**

Test patterns are turned **off**

Geometry, Edge Blending and all Beams are turned **on**

Channel mode is **selected** if in Dome (Frustum) mode

**Servers**

View the **list** of connected servers (see [Server List Dialog](#) <sup>57</sup>)

Display **switches** (go to the Switches workspace) (see [Switches](#) <sup>272</sup>)

Copy **Timeline** to other servers (see [Copy Timeline](#) <sup>57</sup>)

**Save Group as TGA** opens a dialog to copy the playback window as a .tga image

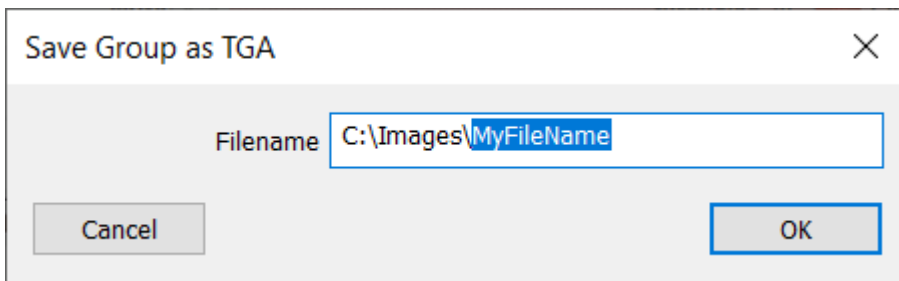

**View (Delta) Web Service** opens Delta Web Service in the default browser on the DeltaGUI PC.

(see [Managing Delta Media Servers: Delta Web Service](#))

**View**

Control what you need to see in DeltaGUI, but usefully, global views of resources available and in use:

- [Toolbars](#) <sup>89</sup> and [Status Bar](#) <sup>70</sup>
- [Configure Timelines](#) <sup>86</sup> (Ctrl+T shortcut for this dialog)
- Folders in the [Resources Area](#) <sup>79</sup>

- Show the [Timeline Summary](#) <sup>(299)</sup>
- List all timeline [Markers](#) <sup>(290)</sup>
- Open the [Audio Equaliser](#) <sup>(429)</sup>
- Open the [Sequence Editor](#) <sup>(358)</sup> (also Ctrl+Shift+S)
- Show the interactive [Sequence Panel](#) <sup>(371)</sup>
- Open the [Resource Finder](#) <sup>(298)</sup> (Ctrl+F)
- Open the [Art-Net and DMX editor](#) <sup>(340)</sup>
- List timeline names: see [Using Timelines](#) <sup>(84)</sup>
- Populate the [Resources Area](#) <sup>(79)</sup> with resources available on disk, or just on the timeline, and by type

## Encrypted Movies

For handling content-protected (encrypted) movies, see the separate [Delta Content Protection System](#) Guide. Here you can list or ingest encrypted movies.

## Wizards

Wizards to help create:

- [3D Stereo Shows](#) <sup>(140)</sup>
- [Slideshows](#) <sup>(405)</sup>
- import (ingest) resources up to 200 Mb per file (see [Ingesting \(importing\) Resources](#) <sup>(300)</sup>).

Your User Licence code as provided by your supplier can also be ingested here (see [Appendix B: Licensing the Server](#) <sup>(445)</sup>).

## Configure

**Preferences** configuration

see [Setting DeltaGUI Preferences](#) <sup>(93)</sup>.

**TCP connections**

see [TCP Connections](#) <sup>(91)</sup>

## Help

**About GUI**

shows the full software version, and licence details and options.

**Contents**

links to the user guide PDF.

**Online Help**

opens <http://portal.7thsense.one/online-help/> in a web browser, containing all 7thSense user guides.

**Shortcut Keys**

shows a summary of shortcut keys in DeltaGUI.

**Server Connections**

shows a summary of all connection attempts by servers to this GUI.

**External Control**

launches a web browser, showing the external control / sequence help file located on the server, or if found locally on the DeltaGUI PC, from there.

**Command Line Switches**

shows a summary of the available switches you can use when running the server application to alter its behaviour, such as forcing the server to start fullscreen or as a Leader server:

**Affects this run only**

- minimized : show the server dialog and playback window minimized
- minimizedialog : minimize the server dialog only in startup
- fullscreen : make the playback window fullscreen
- delay n : Delay the server startup for n seconds
- nopool : Do not look for resources on disk at startup

**Changes are also stored for next run**

- leader : Change the current mode to Leader
- follower : Change the current mode to Follower
- group n : Change the current group to n
- smpte\_on : Enable the SMPTE tracking
- smpte\_off : Disable the SMPTE tracking

## Workspace Menu

---

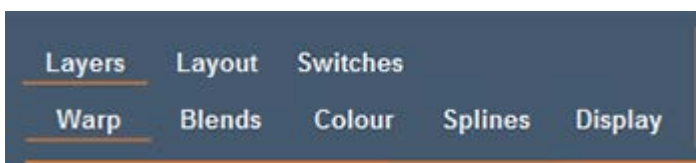

These menus open different workspaces.

The **upper** menu row presents three workspaces: select between [Layers](#)<sup>81</sup> (vertical), [Layout](#)<sup>345</sup> (canvas area) or [Switches](#)<sup>272</sup> (projection) view.

The **lower** menu row opens workspaces for display configuration – the alignment of background effects, as they affect projection to the whole canvas: [Warp](#)<sup>142</sup> (display geometry), [Blend](#)<sup>150</sup>, [Colour](#)<sup>153</sup>, and [Spline](#)<sup>377</sup> editors, and [Display](#)<sup>127</sup> (canvas) Configuration pages.

## Server Selection

Each server is identified uniquely by its Ethernet IP Address. The machine name is presented here under Servers, and either L: or F: to indicate whether this machine is configured as a Leader or Follower machine within the group.

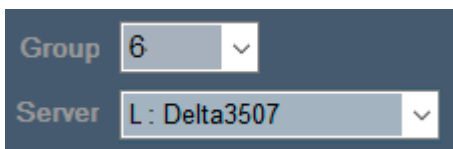

You can configure the selected server in [Configure > Preferences](#)<sup>94</sup>.

## Timeline Selection

Servers can have up to 32 independent timelines depending on model, you can select between these timelines using this dropdown. Colours indicate status:

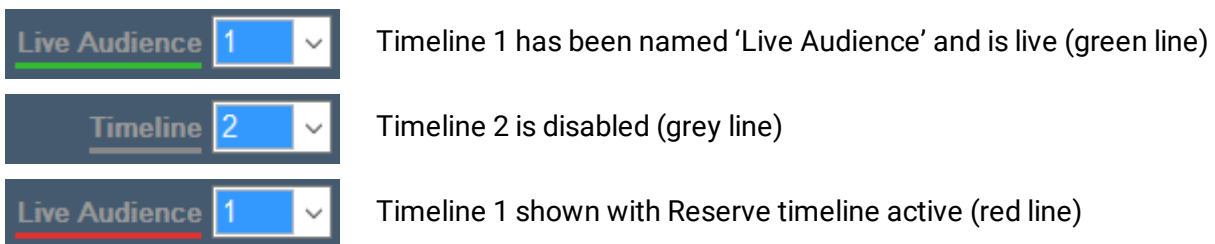

You can name timelines for the selected server using the *Menu > View > Timeline Names* dialog. These names are shown as above, but can also be used during external control, for example naming timeline 1 to be 'upper':

MEDIALAYER myresource 3 TL=upper

instead of

MEDIALAYER myresource 3 TL=1

## Status Bar

The main window status bar carries some useful controls for quick access. Main menu > View allows you to show or hide the status bar.

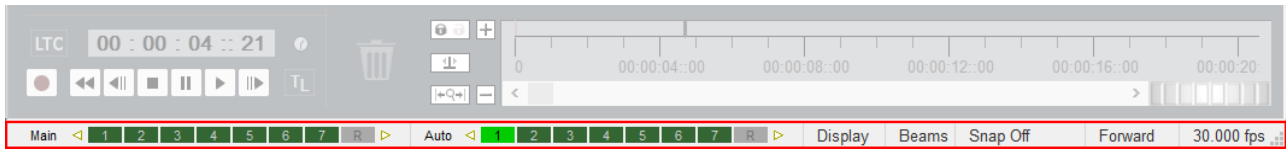

## Main and Auto

These scrollable bars show active timelines (dark green) and whether they are set to autoplay (bright green). Normally they are not interactive, but this can be switched in *Preferences > User Interface > Features*, 'Active Timeline Indicators', so that you can toggle active and autoplay settings:

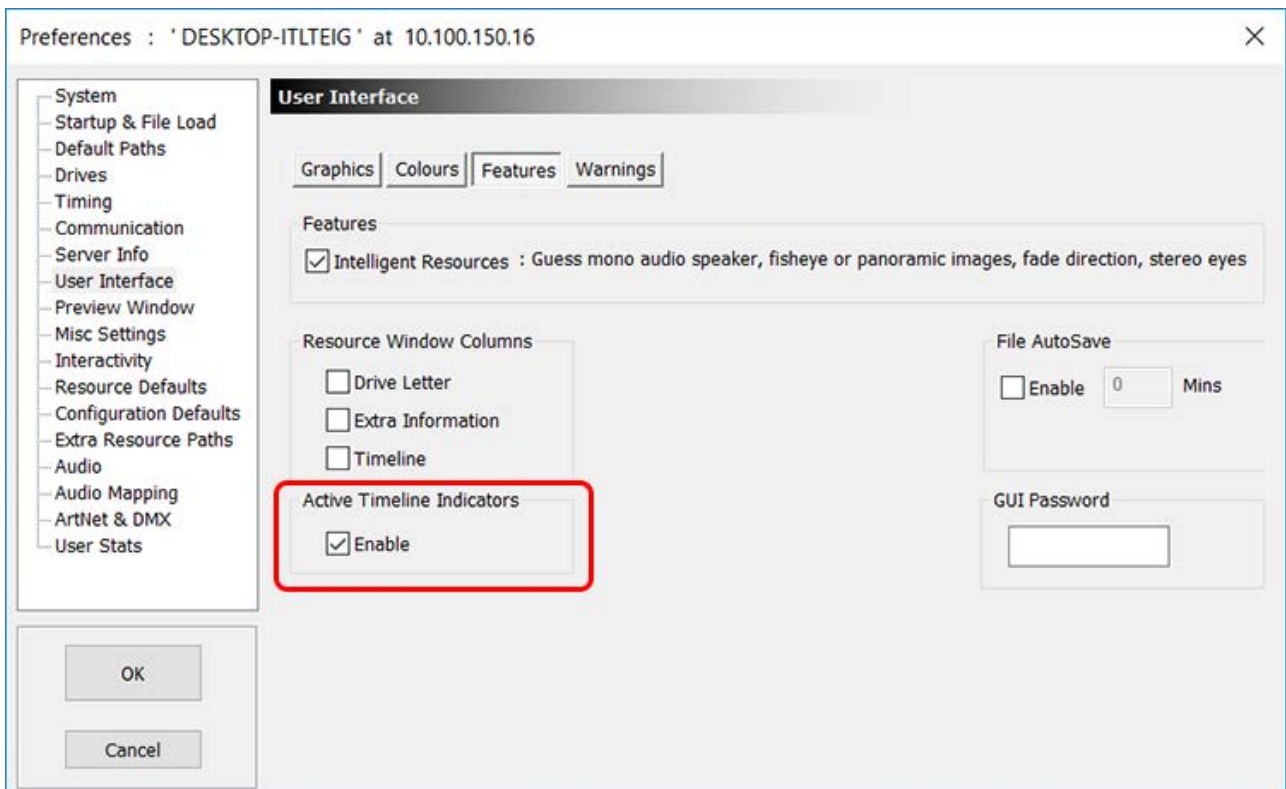

## Display

This quick access menu allows for display of the alignment grid, a test pattern, to switch geometry and blends on and off, or to revert to full audience-ready show mode in one click:

Display	
Apply Show Mode	
✓	Geometry
✓	Blends
✓	Blend Softness
	Test Patterns ▶
	Grid ▶

## Beams

Switching RGB beams on and off by all in a Group or by channel can be useful in display setup and channel identification:

Beams	
Group Beams ▶	✓ R
Channel 1 ▶	✓ G
Channel 2 ▶	✓ B
Channel 3 ▶	ALL OFF
Channel 4 ▶	ALL ON
Channel 5 ▶	

## Snap Off

This provides quick access to the same settings as in *Preferences > User Interface > Features*, 'Graphics' for how resources snap to the timeline layer grid.

## Forward

Switch the play mode (direction) from Forward to Reverse even during play (from version 2.6.74). Note that the Spacebar is a stop/play control in the Preview Window, and Shift+Spacebar will reverse play.

## fps

Quick access to the timeline play rate as found in *Preferences > Timing*.

## Layers Menus

---

There are two additional menus available in Layers view, 'Layers' and 'Update'.

## Layers

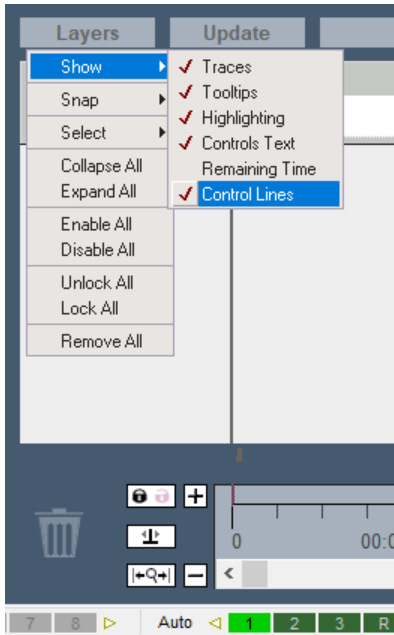

### Layers menu: Show

These menu options are mainly to help provide detail only when necessary, and declutter the Layout panel if not. These settings are retained when DeltaGUI is closed.

### Traces

Show Traces shows or hides the horizontal lines that extend from the transparency or fade up / down resources. These are useful if you have complex sets of up/down fades and don't want the added complexity of the lines:

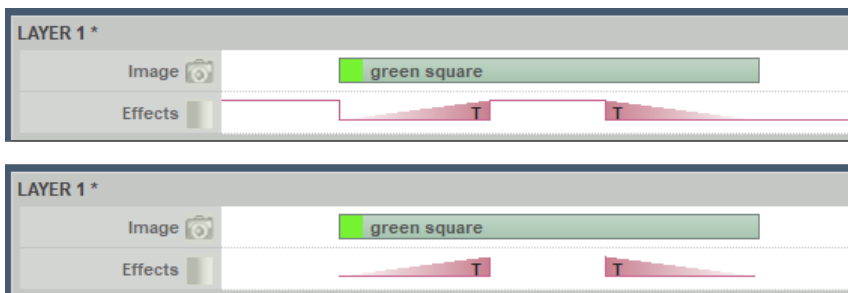

### Tooltips

This enables or disables tooltips for timeline resources (mouseover to reveal properties):



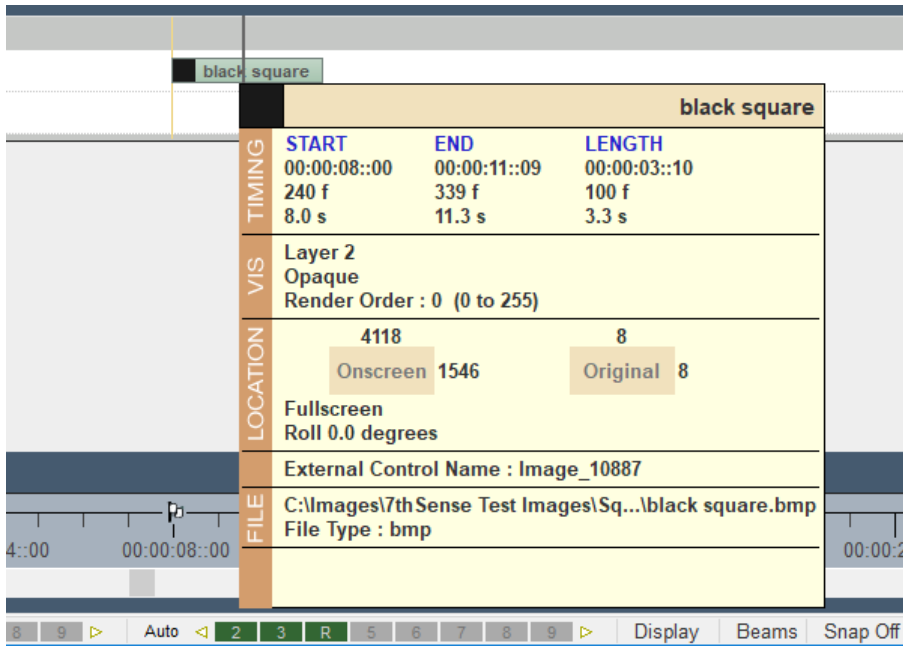

**Highlighting**

This enables or disables timeline resource highlights (i.e. displaying yellow with resource start and end times when clicked for dragging):

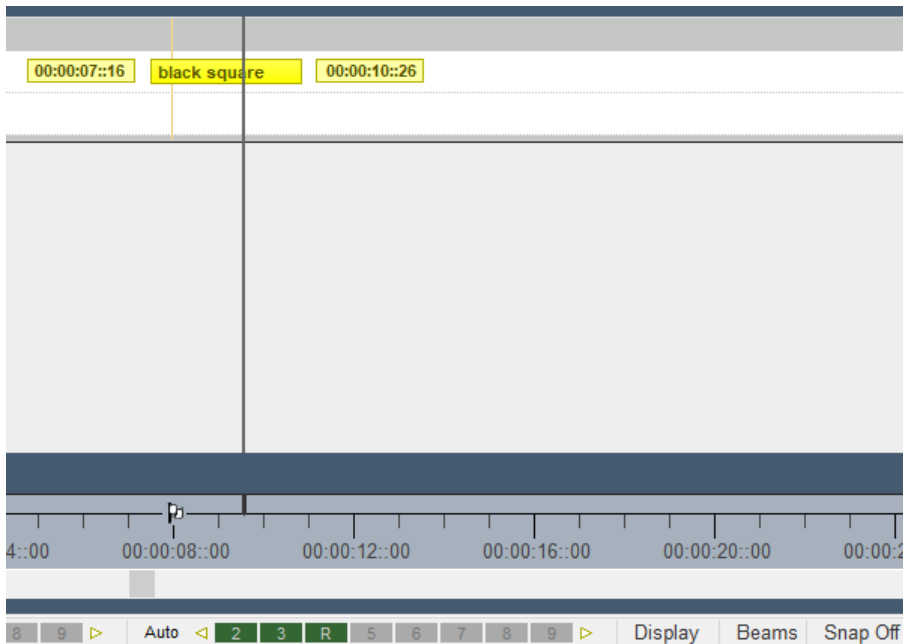

**Controls Text**

Controls can be assigned (*Resource Editor > Marker > Timeline*) to keys (e.g. F2). This normally shows in red, but can be turned off here:

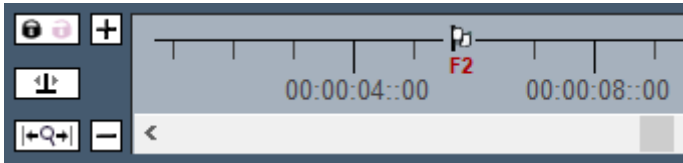

### Remaining Time

When on, this shows the time position of the playhead within a resource:

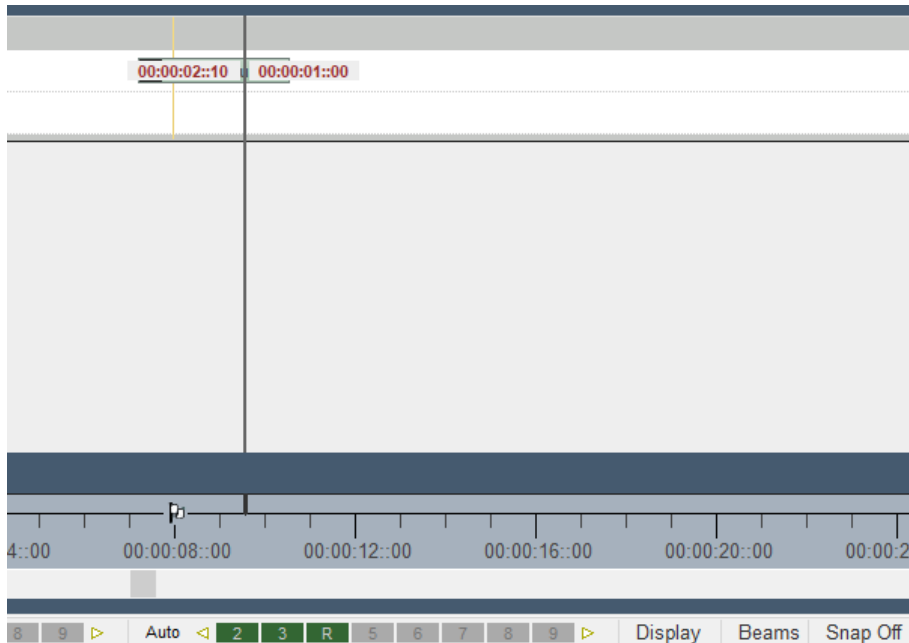

### Control Lines

In the above illustrations you will see the yellow Control Line, showing where a marker is, in the layer. This can also be a help when adding a new resource: hold shift when dragging a new resource and it will snap to the control line of the marker when close, even if the normal snap controls are off.

### Layer Menu: Snap

Off / Grid Only / Grid & Resources are also set in *Preferences > User Interface > Graphics 'Snap'*, or from the DeltaGUI status bar, where grid size and units can also be set:

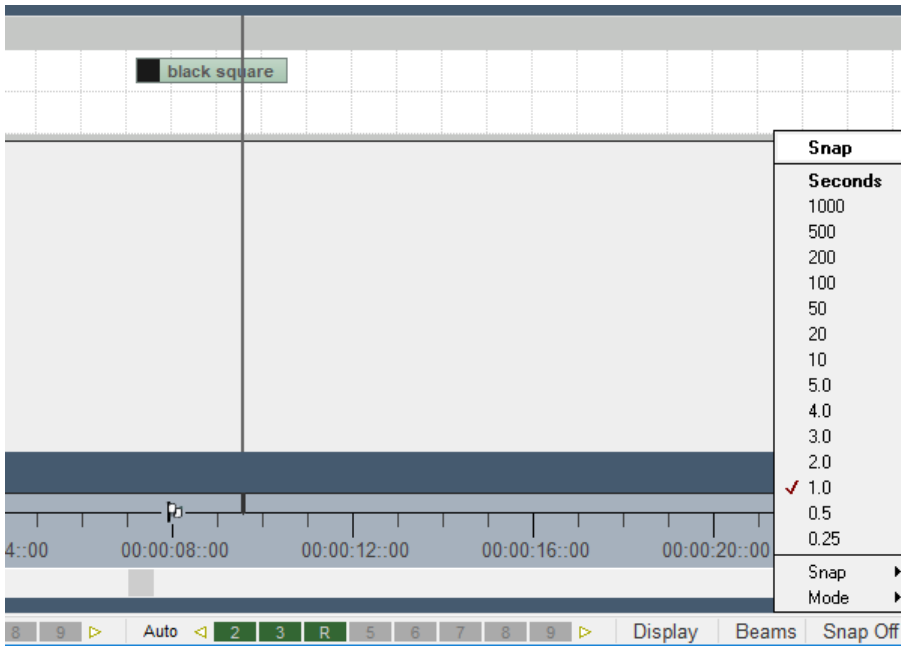

**Select**

This will select all resources showing to the left or right of the playhead position.

**Collapse / Enable / Lock / Remove**

This treats all layers together on this timeline.

**Update menu**

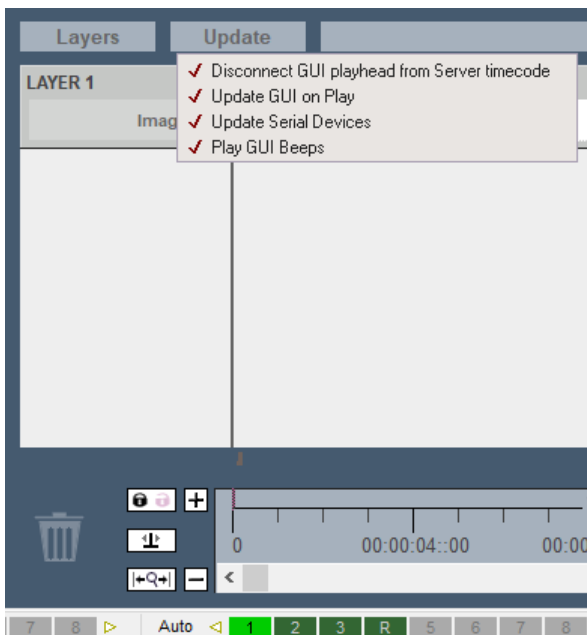

The DeltaGUI timeline refreshes constantly (*Preferences > User Interface > Graphics 'GUI Update Frequency'*). Here you can lighten the load on the DeltaGUI PC (e.g. for a lower-spec laptop).

### Disconnect GUI playhead from Server timecode

This is the same as the padlock button in the timing area – when disconnected (magenta), you can go off and edit somewhere else on the timeline instead of being near the server's playhead position, so that playback is not interrupted. The timecode cursor also turns magenta (see also [Timing Area](#) <sup>(78)</sup>).

### Update GUI on play

Where there are many resources on a timeline, the flow can become juddery when playing. You can choose not to see the DeltaGUI timeline moving along when playing. This setting still allows normal tracking along the timeline when editing a show.

### Update Serial Devices

Don't output serial device resource commands (i.e. temporarily disable them to allow show programming without triggering external equipment in a live scenario).

### Play GUI beeps

Beeps are audible markers that can be placed as timeline markers. Switch the (local server) sound on or off here .

## Server Messages

---

Next to the Layers and Update menus is an area that both displays timeline error messages (in red) and a log of all messages sent by this instance of DeltaGUI as client to any DeltaServer. Find the small arrow on the right to open the log:



All messages are listed, with their source:

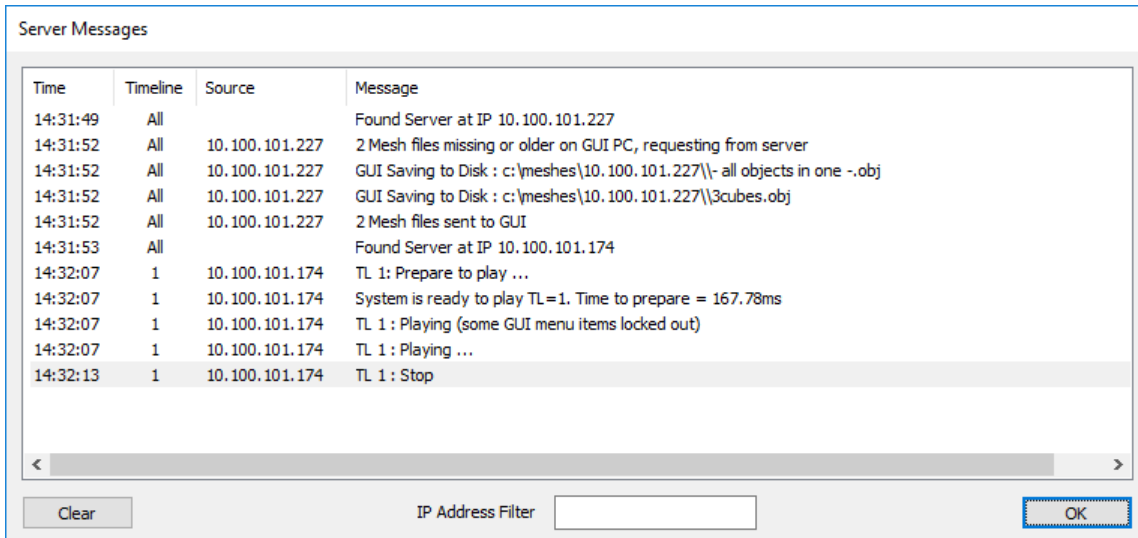

To track just one server connection, add the required IP Address to the filter, and only messages to this server will be logged. The log can be useful for identifying connection issues with any server.

Press Clear to delete all entries in the log. This page is also cleared when DeltaGUI is closed.

## Timeline Controls

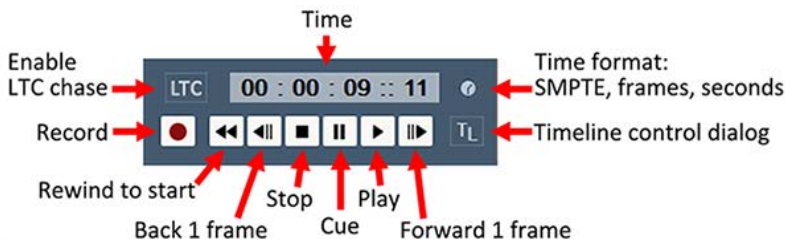

## Reverse Playback

This feature was added to DeltaGUI **from Delta 2.6.74**. It is not available in earlier versions and builds.

Hold Shift whilst clicking the play button and play will reverse. The play button will stay in reverse mode until Shift+Play are combined again. Alternatively, use the Reverse/Forward menu in the right side of the status bar:

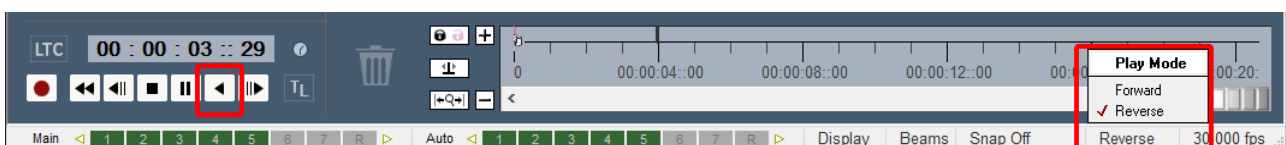

The same holds true for the DeltaServer dialog playback controls.

In the DeltaServer Playback window, the spacebar is the normal play/stop keyboard control. Playback can be toggled in the Playback Window, between forwards and reverse using Shift+Spacebar.

In reverse playback, the following are disabled:

- audio
- looping
- Art-Net
- recording

## Timing Area

This allows the user to interact with the current frame, moving back and forth along the timeline, and zooming in or out to show different parts of the timeline.

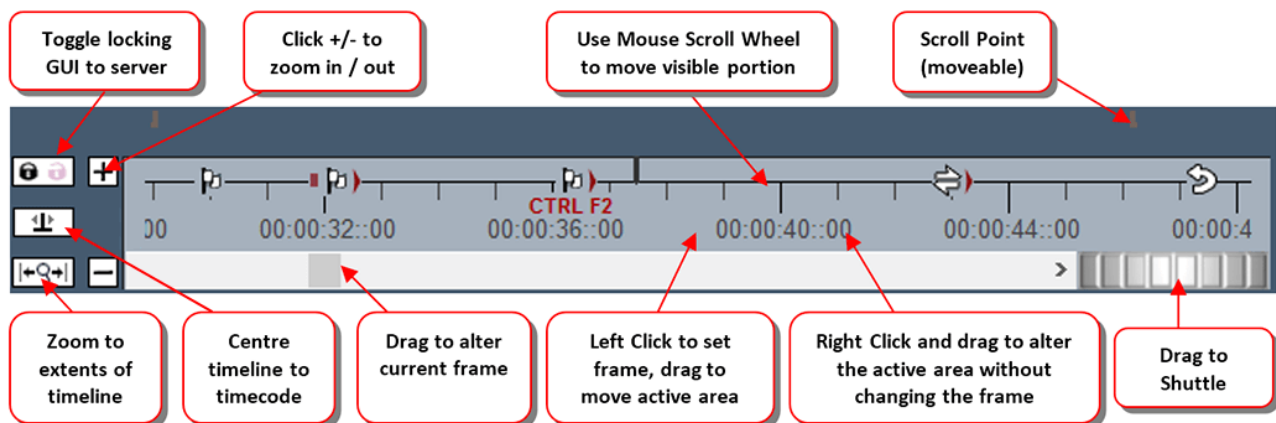

Timing resources are shown here, such as Loop, Stop, Markers etc. You can edit by dragging them, right click to disable, delete etc., or double click to edit the properties.

The two **Scroll Points** can be dragged from the left / right edge into the middle so that the timeline advances there, showing what's coming on the timeline more easily.

The **Shuttle** controller can move forwards and backwards through the timeline at different speeds, drag more to the left or right to speed up, release to stop again

The DeltaGUI Lock / unlock toggle switch is used to toggle between locking DeltaGUI to the server's timecode (default behaviour when DeltaGUI runs) or unlocking DeltaGUI from the server's timecode so that you can edit the timeline somewhere other than the current server timecode.

**GUI locked to server** (padlock icon is black / locked): GUI timecode cursor is black and tracks the server's timecode. Adding new resources or editing, changing configuration and file loading or saving are all disabled while the server is playing, so that playback is not interrupted.

**GUI unlocked from server** (padlock icon is magenta / unlocked): GUI timecode cursor is magenta and is independent of the server's timecode. All editing, configuration or file operations are available while the server is playing, but note that playback can be interrupted (stall or stutter in playback) if, for example, file saving or other operations are used.

**Zoom Extents** (Shift+Z) zooms the timeline out to show all resources.

## Resources Area

Delta servers hold resources, which can be media (images, movies, colours), transformations and manipulations, device controls and effects, captures of external media, containers of other media, or 'macro' sequences for control within a show.

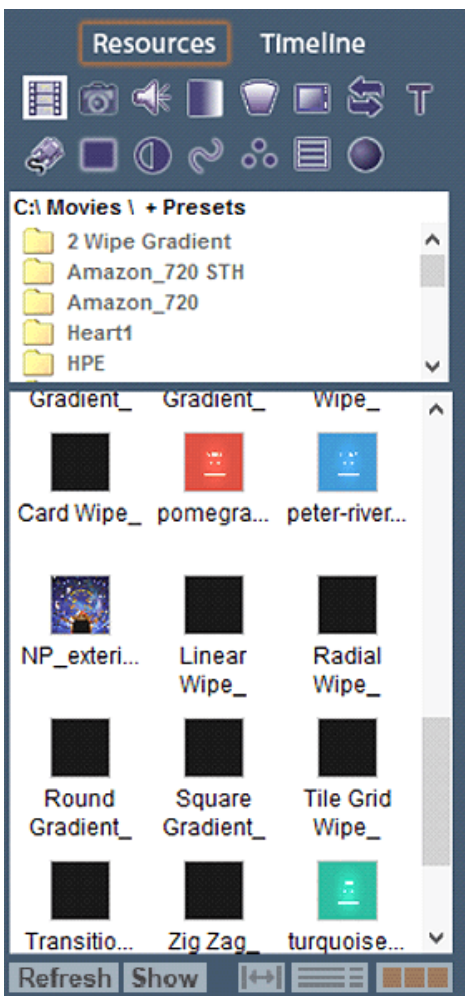

Clicking the Resources / Timeline tab switches from viewing all the available media and resources on the disk [Resources] to viewing the resources that are present on the current timeline [Timeline].

Pressing the various Media buttons on the Resources area selects different types of media to be listed – in the example above, Movies are selected.

You can drag media from here to a timeline layer when viewing Resources, and edit the resource on the timeline by double-clicking.

Hover the mouse over an icon to view further information about that media.

If new content has been added to the server, press Refresh. (The list is not dynamically updated in order to avoid adding network traffic.)

To show only Presets, Resources or Presets and Resources, press the Show button.

To swap between icon and detailed view, use the two buttons on the lower right.

The middle button:  will expand the width of the resource panel.

Alt+V+F is the quick key to reveal the full resource folders.

## Resource Folders

In the image above, the Resource Folders are shown (Menu: *View > Resource Folders*).

With this active, only the resources contained in the folder on the server at the top are shown, allowing you to see only those you are interested in by grouping the various resources within subfolders.

## Extending the Pool View

In detailed, rather than icon view, long resource names can be read more easily by expanding the view. Press the expand button or use **Ctrl+Q** to toggle the extra panel width.

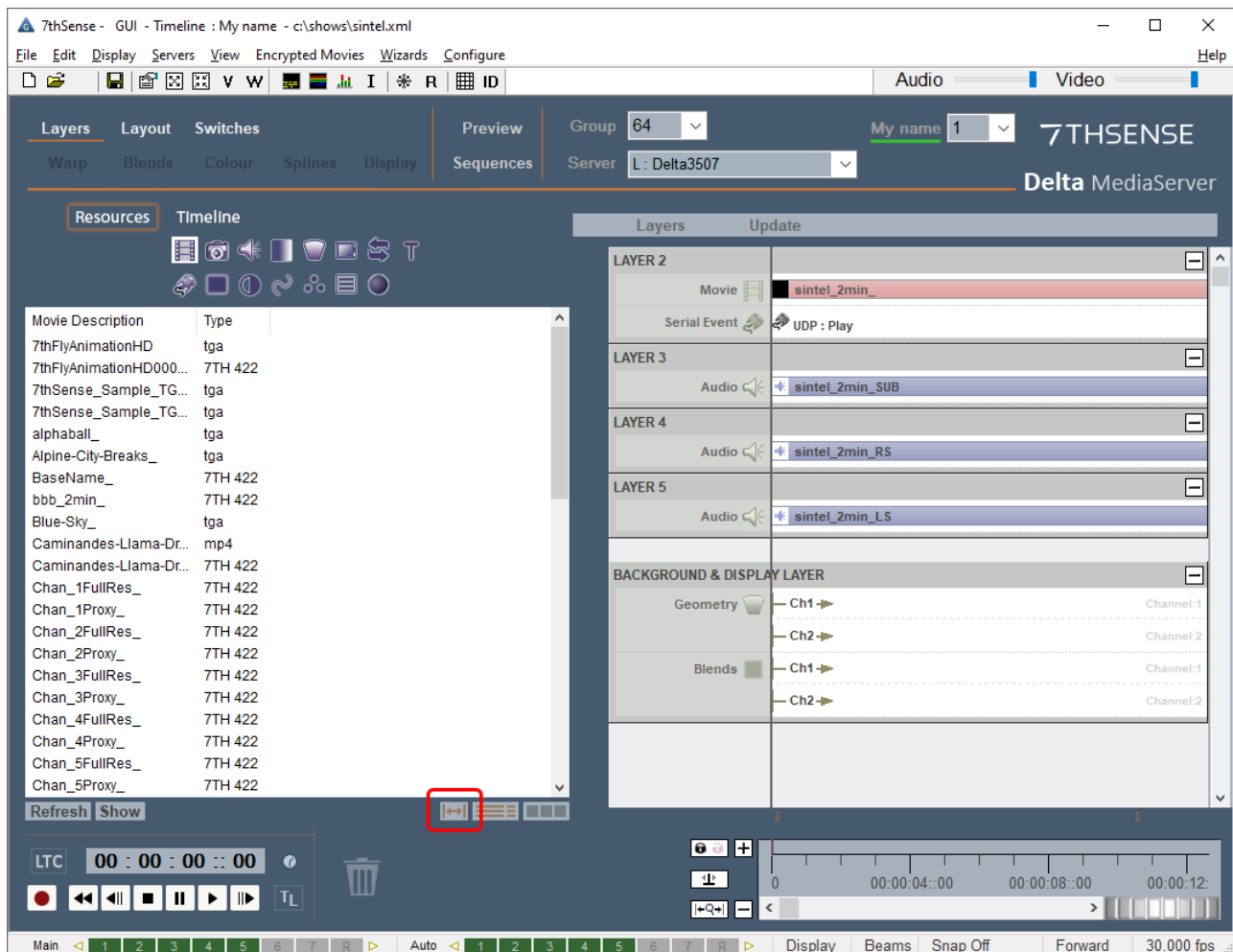

## Customise the expanded width

There are two registry settings that configure the expanded width, in:

Computer\HKEY\_LOCAL\_MACHINE\SOFTWARE\WOW6432Node\7thSense\DeltaGUI\Layout\Flat



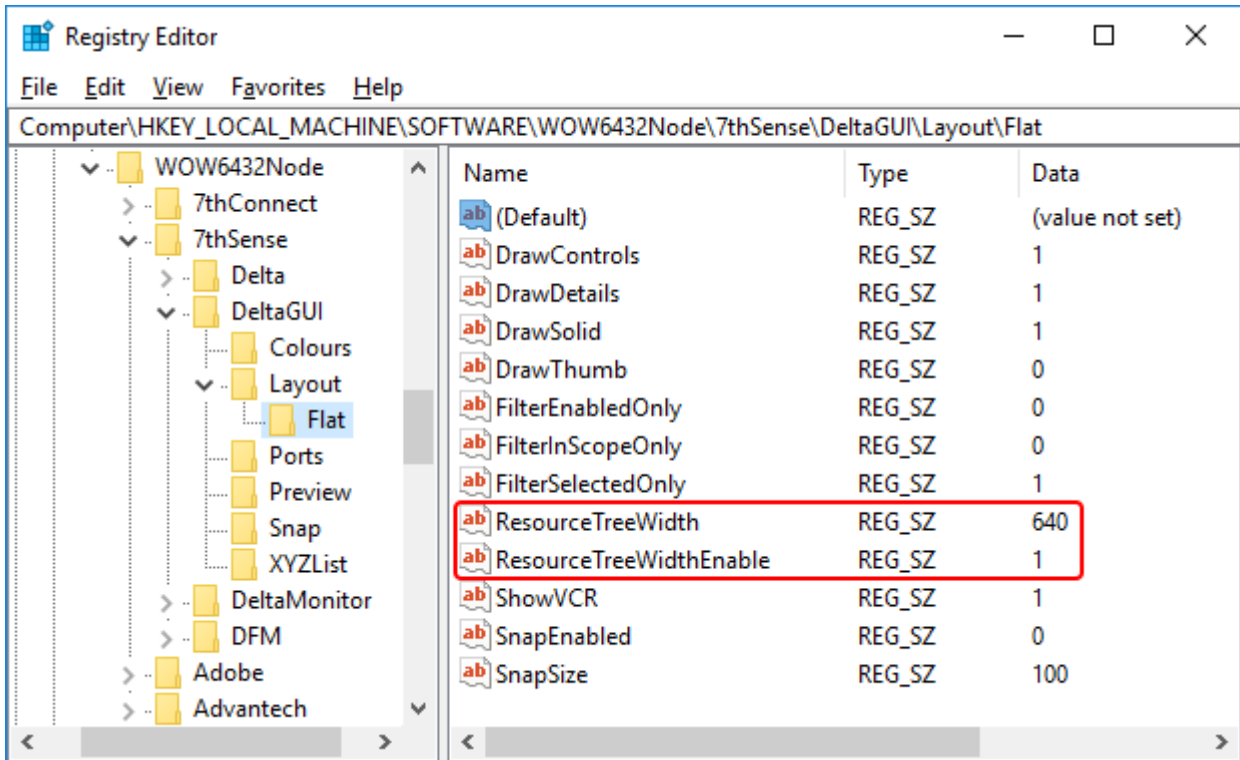

- Close DeltaGUI.
- ResourceTreeWidth: This is initially set at 480. Set your custom width.
- ResourceTreeWidthEnable: 1 = start DeltaGUI using the custom width; 0 = start DeltaGUI using the default width.
- Restart DeltaGUI.

## Layers Area

This shows the various user-created layers containing the media. Note that layers higher up the screen obscure those below them (Layer 1 in this example would obscure Layer 7 after the transparent fade and where there is active content on Layer 7).

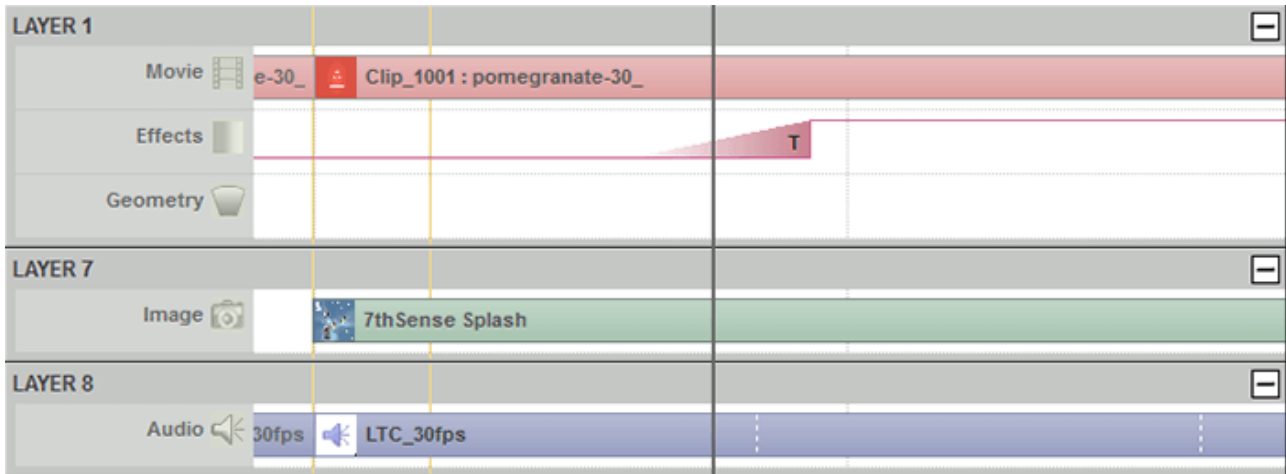

You can edit properties on a resource by double clicking it, or right click and select Properties from the menu.

Hovering the mouse over the resource will give further information on it:

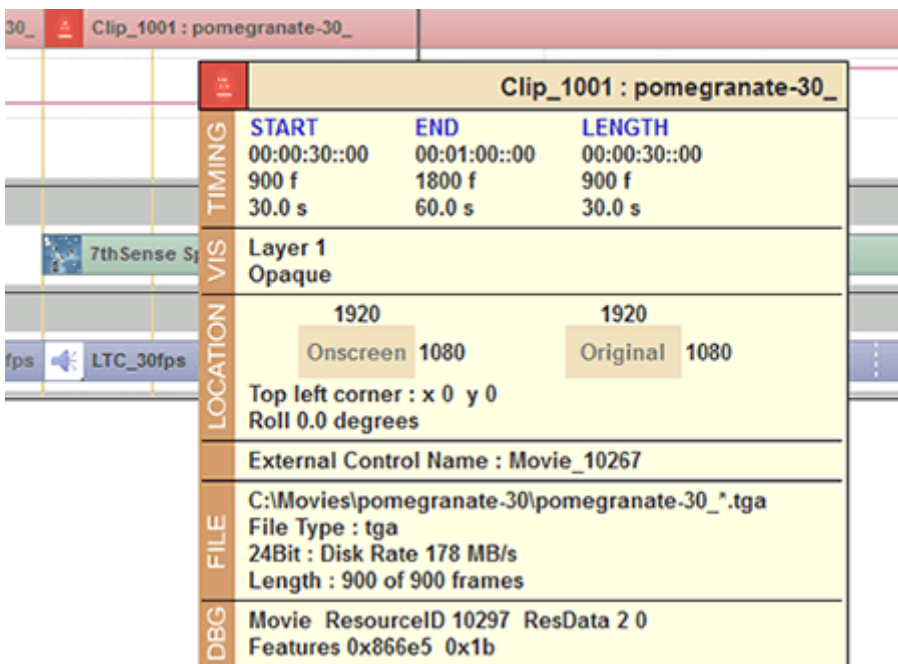

A resource position and length on the timeline can be altered by dragging it in the middle or either end.

If, by dragging, one resource overlaps another in its layer, the left-most resource will be 'bumped' down within the layer. By applying render order to visual media of a kind, in the same layer, more control can be given to their positioning. This places them into sublayers (see also: [Timeline Summary](#)<sup>(299)</sup>):



Delta can have up to 250 layers on a timeline. These are sequentially numbered, so inserting or removing a layer will adjust other numbers. These number references can be used in show programming (Sequences). To preserve numbering you can assign groups of media (e.g. a movie with its audio tracks) to layer groups (e.g.: layers 1-10, 100-110, 200-210).

## How Layers Work

There are three kinds of layer:

### Playback layers

Any media can be applied to these layers, including animations, geometry, sequences etc. These layers can be deleted, re-ordered, enabled, collapsed and locked, and reside above Art-Net and Background layers.

### The Art-Net and DMX lighting control layer

All Art-Net controls reside separately in their own layer.

### The background and display layer

This layer contains warps, blends and colour, and is included in the information that comprises the display configuration file (.xdl). It therefore applies to all Timelines.

In the Delta 'Layer' concept, movies, images, audio etc. can be placed on up to 250 separate layers. Where images and movies occupy the same part of the canvas at the same time, the higher layer will be shown. Imagine looking into a pool, where lily pads may obscure all or part of the water, where fish viewed between the pads themselves obscure weed below them, and so on. Whatever the Layer number, the stack of layers is like the pond, with the surface at the top. Opacity / transparency is a property of a resource in a layer, not of the the layer itself.

You can alter each image or movie's transparency, so that layers below are only partially obscured, and even perform crossfade-type transitions between layers to provide smooth effects (see [Timeline Effects](#)<sup>(396)</sup>).

**How visual layers appear** (note layer 1 obscures layer 12):

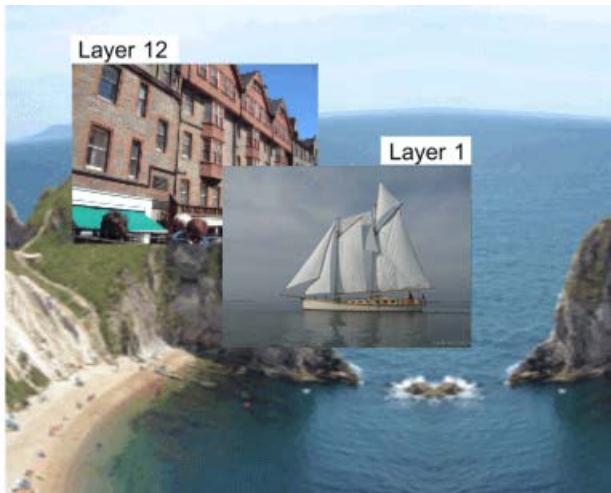

Background Layer

**How layers are actually arranged** inside Delta – Layer 1 is higher than layer 12, which is higher than the background layer:

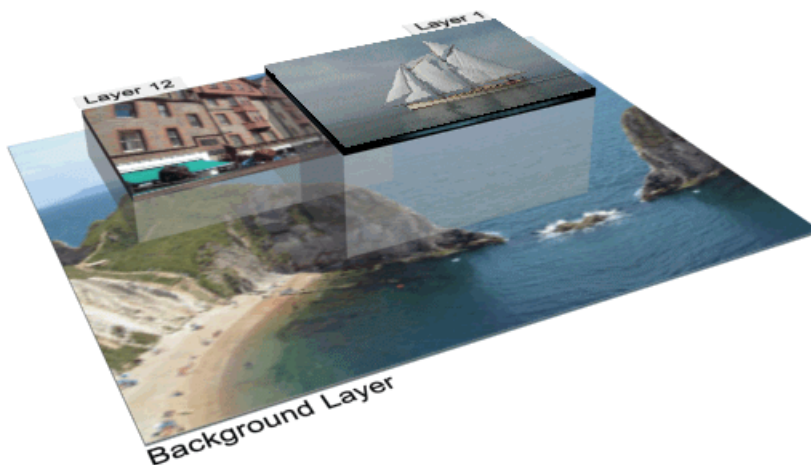

The same applies to sublayers (render order) within a layer.

## Using Timelines

Delta can have multiple timelines, which are independent of each other within the same server. This allows you to create and present timeline 1 to the audience while editing timeline 2 in the background, then smoothly crossfade between the 2 timelines. You can also use other timelines for purely audio, or as control timelines for Serial Events.

Timelines are interleaved by opacity masks of their own. How timelines interact in terms of their opacity and layer precedence, is determined by the Timeline Mode, in the Timelines Dialog ([Configure Timelines](#)<sup>(86)</sup>).

## Reserve Timeline

This is an interactive mode such that when active, only those resources on the reserve timeline (not single-channel Delta Nano) are shown, and pressing the [R] button on the toolbar (or Ctrl+R, or through external control) fades between normal operation (current timelines shown) and Reserve Mode (Reserve timeline only shown).

This enables users with live events happening at unknown times (for example) to play a movie, then gracefully fade to a background image, move the timeline head to a new position (the audience still see the background image while this is happening), then start playing a new movie and gracefully fade up.

You can choose which active timeline is the Reserve timeline on the Timeline dialog (Ctrl+T), and set the fade time in *Preferences > Misc Settings*.

'Out of the box', there are two active timelines, 1, and 8 assigned as default [R]eserve. This is suitable for placing an image onto timeline 8 to which to fade, non-playing. Once you configure multiple timelines, your Reserve must be one of these, and can hold and play movie and audio resources.

## Timeline Names

Timelines are numbered 1 to 32, but you can name each timeline such that external control or sequences can use the named timeline:

Mediainsert type=image resourcename=white TL=Backup

instead of:

Mediainsert type=image resourcename=white TL=3

You can access the timeline names in DeltaGUI from the menu, *View > Timeline Names*.

This name will show to the left of the timeline dropdown, also above the slider for that timeline in the Timelines dialog and in the DeltaGUI title bar.

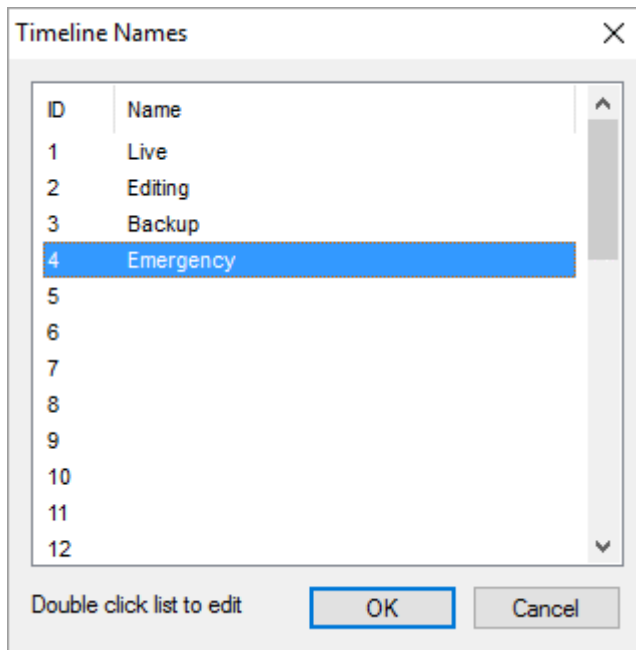

**Note** that timeline names are stored in the show XML, *File > New* will reset them to numbers only and they are **not** loaded with XDL files (as with other timeline parameters).

## Configure Timelines

Access the timelines dialog with Ctrl+T, or from the TL button in the bottom left of DeltaGUI, or View Timelines from the menu.



This brings up the timelines dialog from where you can change the opacity of each of the timelines, configure how many live timelines you have, and play/stop/cue individual or all timelines.

**Note:** Cue is not 'Pause'! It preloads frames so that Play is then instantaneous.

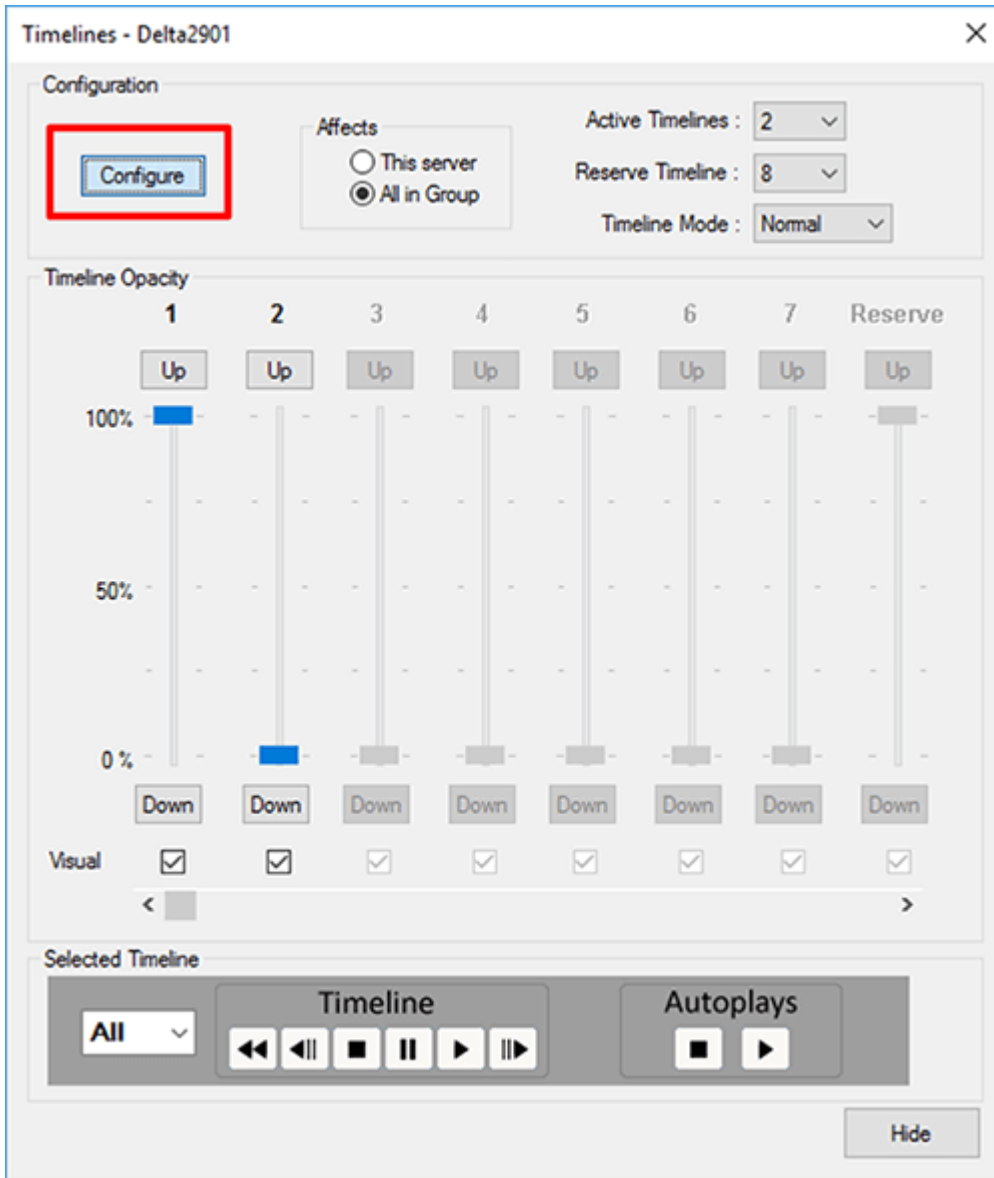

Pressing **Configure** activates the controls at the right of the dialog, and the 'Visual' (uncheck to disable visual resources only) checkboxes per timeline. You can now choose how many **Active** timelines you need.

You can also set which active timeline is designated as **Reserve** so that pressing **Ctrl+R**, or the **R** toolbar button in DeltaGUI – or calling the Reserve command in a sequence – fades down to this timeline. You can also turn off Reserve capability completely, allowing all 32 timelines to be used.

## Timeline Mode

Choice of mode can improve rendering efficiency, but implies careful design considerations. The simplest approach is Normal, but is most demanding. The most efficient is Global Z.

**Normal**

Higher timelines (1 is the highest) obscure lower timelines and the opacity values set the opacity of the entire timeline. The opacity is a black background to each timeline. This does not affect the opacity of individual resources in their layers.

**Global Z**

Layers across all timelines are Z Order, so layer 1 on any timeline is higher than layer 66 on any other timeline.

**Composite**

This mode is the same as Normal, but with transparency between timelines.

**Normal Mode**

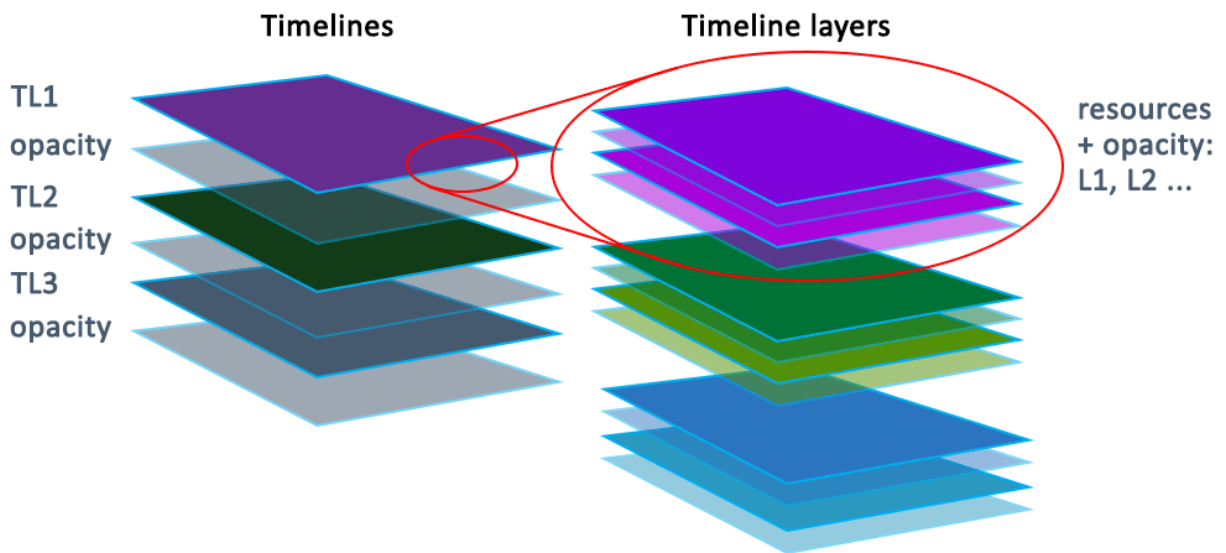

**Global Z Mode**

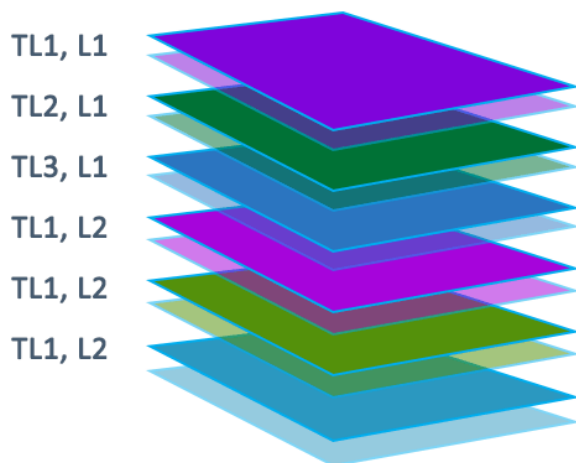

**Composite Mode**

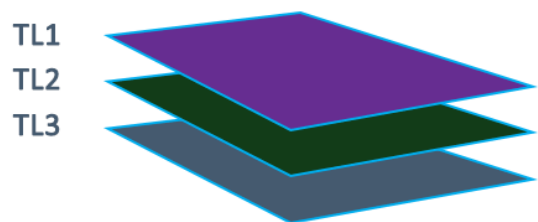



## Affects

Choose **This Server** for one server only, or **All In Group** where opacity sliders will affect all servers in the group.

You can also set a timeline to be Visual or not with the checkboxes below each timeline – Visual timelines increase rendering load, so you may have a non-visual timeline for audio-only, for example, which does not add to the graphics rendering load

## Timeline Playback Controls

You can select All, 1-32 or R for the play/stop/cue controls etc.



You can also Stop or Play all movies set to Autoplay in the selected server or all servers. Autoplay movies will always start playing from frame 1.









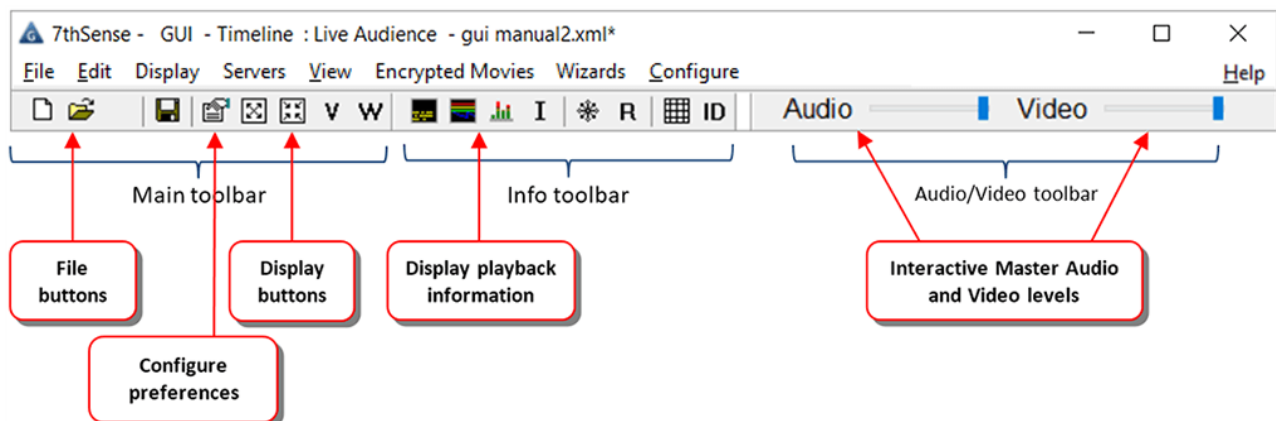









### Timeline Up/Down buttons

Pressing these triggers a 1 s up or down timeline opacity fade.

## Toolbars

There are three toolbars positioned by default at the top of the DeltaGUI layout. These can be undocked separately and redocked in any order. The default positions are resumed after closing DeltaGUI.



-  File New
-  File Open
-  File Save
-  Configure Preferences
-  Display Windowed (group)
-  Display Fullscreen (group)
-  Launch VNC Viewer  
(configure password in Config > Preferences > System)
-  Launch Delta Web Service (on Local GUI PC) using default browser
-  Toggle Playback Statistics (group) display on preview
-  Toggle Graph (group) display on preview
-  Toggle VU Meter on preview
-  User Information toggle (playback window)
-  Toggle Freezing Video Capture (group)
-  Toggle Reserve Timeline (group)
-  Show on-screen pixel grid
-  Channel ID: toggle playback window display of server, channel number and SMPTE timecode
-  Overall Audio Level (group)
-  Overall Video Fade (group)

**Note:** Display buttons, on-screen graph and playback statistics buttons, Reserve Mode, and the interactive sliders, affect all servers in the same group.

## TCP Connections

Select *Configure > TCP Connections* (Ctrl+Shift+T) from the main menu. This enables Delta to **connect as a client** to other devices.

**Note** that this is not the same as TCP connections *into* Delta (as server) for external control, as set up in *Configure > Preferences > Communications* (see [Communication Configuration](#)<sup>102</sup>).

Establish permanent Telnet connections (e.g. to projectors), kept open for sending messages, along timeline as serial events.

Name	IP Address	Port	Connected	Enabled	Process Replies	Fire System Seq	Instances
Connection1	192.168.0.5	23	No	Yes	Yes	Yes	0

Buttons: Add, Remove

Once established, TCP connections can then be added to the timeline from Serial Event resources, then selecting the connection by name, and adding target device commands in the resource editor:

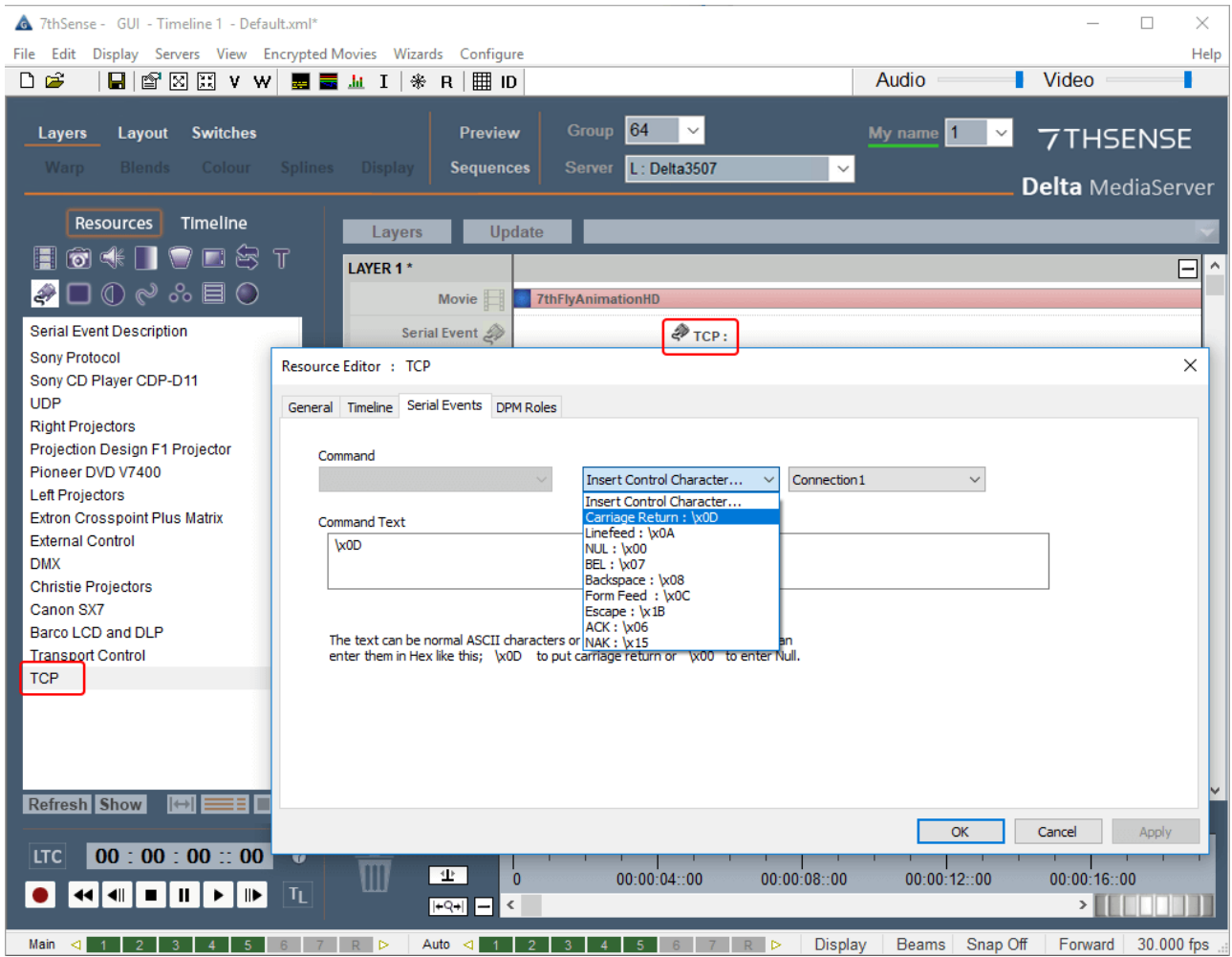

## Setting DeltaGUI Preferences

---

Start DeltaServer and DeltaGUI. Choose *Configure > Preferences* from the menu. If the server requires licensing, see [Appendix B: Licensing the Server](#)<sup>(445)</sup>.

- [System Configuration](#)<sup>(94)</sup>
- [Startup and File Load Configuration](#)<sup>(95)</sup>
- [Default Paths Configuration](#)<sup>(97)</sup>
- [Disk Drive Configuration](#)<sup>(97)</sup>
- [Timing Configuration](#)<sup>(99)</sup>
- [Communication Configuration](#)<sup>(102)</sup>
- [Server Information](#)<sup>(105)</sup>
- [DeltaGUI User Interface](#)<sup>(106)</sup>
- [Preview Window / Record Preview setup](#)<sup>(112)</sup>
- [Misc Settings](#)<sup>(113)</sup>
- [Interactivity](#)<sup>(114)</sup>
- [Resource Defaults](#)<sup>(116)</sup>
- [Configuration Defaults](#)<sup>(117)</sup>
- [Extra Resource Paths](#)<sup>(118)</sup>
- [Audio Type](#)<sup>(120)</sup>
- [Audio Mapping](#)<sup>(121)</sup>
- [Art-Net and DMX Config](#)<sup>(123)</sup>
- [User Information / Stats](#)<sup>(125)</sup>

## System Configuration

On the System Configuration page, the current server name and its Ethernet IP Address is shown:

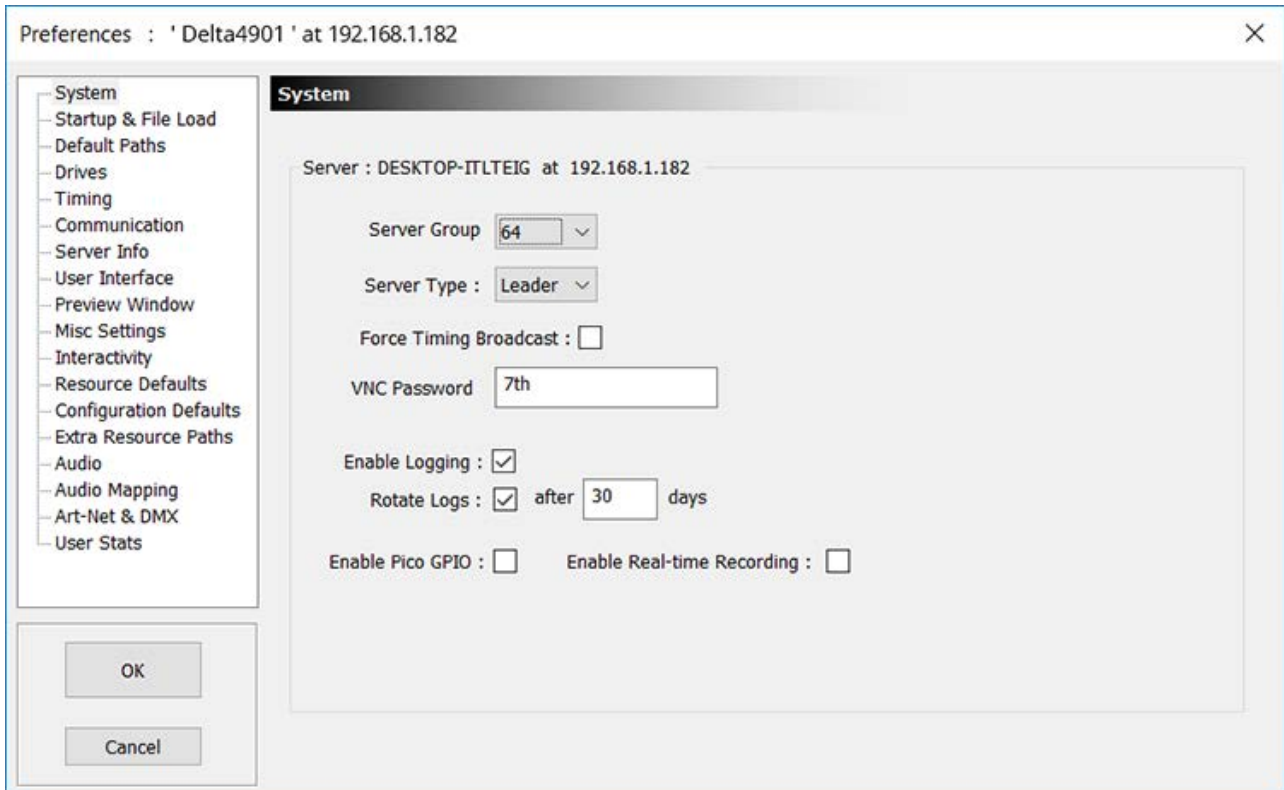

You can configure which group this server belongs to, using the **Server Group** drop-down list.

The **Server Type** is either Leader or Follower for multi-rack configurations. For single rack systems set this to Leader.

Avoid having two Leaders in the same group; this leads to conflicts in timing.

**Note** that Edit Station licences can only be a Leader and will not control Follower nodes.

### Force Timing Broadcast

If off, timing information is broadcast from the Leader server only when Follower servers in that group are detected by the Leader server – this cuts down on network traffic. With this option on, timing information is always broadcast for this group, which can be used by other equipment listening to this timing.

**VNC password** is used with the **V** toolbar button to automatically login to the Delta server  
Default password: 7th

### Enable Logging

If enabled, will write a debug log to disk (C:\Program Files\7thSense\Delta\Log), a new log will

be started each day if the server application is run on that day. If DeltaServer crashes, an additional file is generated, prefixed 'DeltaServer\_MiniDump-[version]~.dmp'.

### Rotate Logs / After N days

If enabled, log files older than N days will be deleted.

### Enable Pico GPIO

Check if you are using the [GPIO capability of a Pico](#) media server. GPIO pin behaviours are set by external control.

By default this is not enabled in order to maximise performance for media.

### Enable Real Time Recording

[Real-Time Recording](#) <sup>(424)</sup> (also named Preview recording in previous versions of Delta) also occupies bandwidth when enabled. Enable here for real-time recording only; show recording is not affected.

## Startup and File Load Configuration

On the Startup and File Configuration page, you can configure how the server behaves at start up and on any file load.

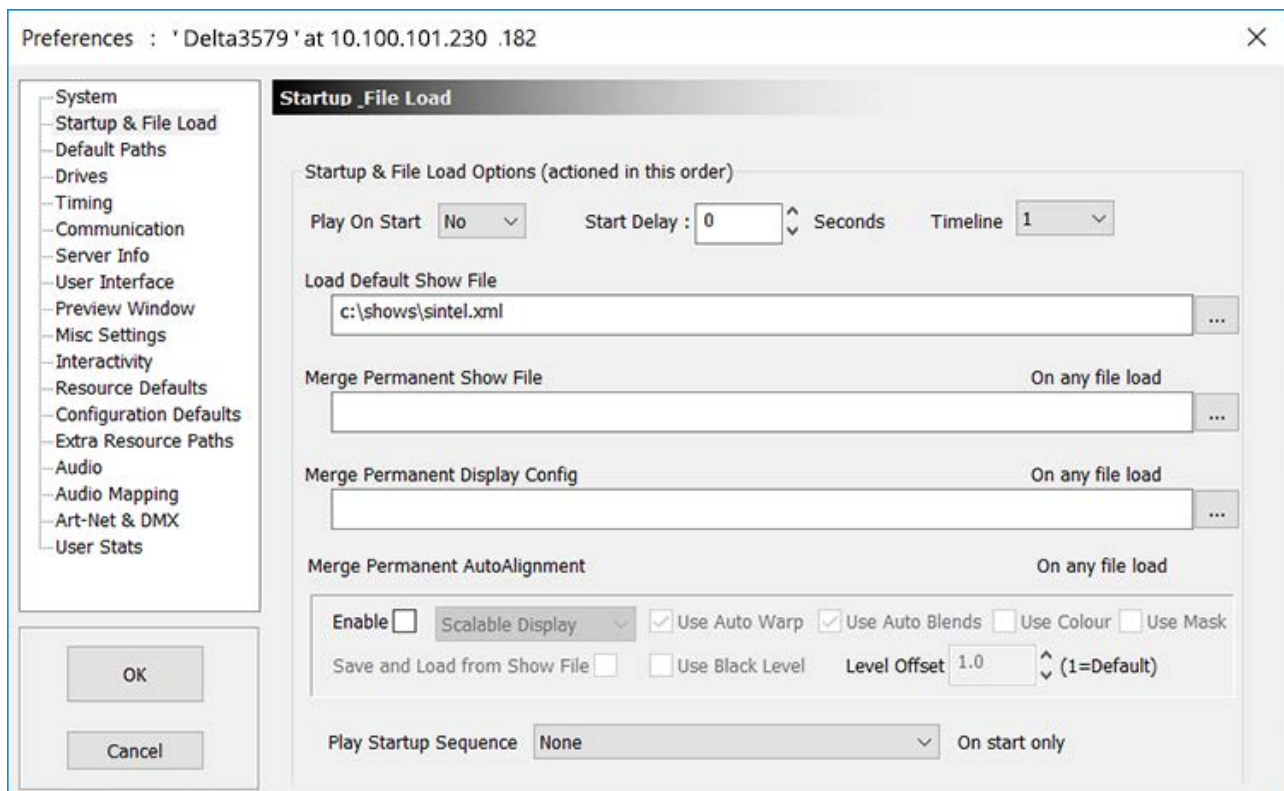

**Play on Start**

Set to Yes to immediately play the default file when the server runs. This is the default for a standalone server. This will make the Playback Window full-screen when the server is started.

**Start Delay**

the number of seconds after loading that Delta will wait before loading and playing the default show. On a Leader rack, set this to 10 seconds longer than the Follower rack delay to give the Follower racks time to get ready.

**Timeline**

which timeline you would like to play on start from a multi-timeline setup.

**Load Default Show File**

the file to be loaded when the server starts.

**Merge Permanent Show File**

specifies an XML file (saved from Delta, contains resources only) which is loaded after any file load to allow you to have a separate XML containing any resources which are common across all files.

This can be used for example to load a Masks.XML which contains image masks common to all show files used to mask out particular areas of the display.

**Merge Permanent Display Config**

specifies an XDL file (saved from Delta, contains background geometry, blending and display config only) which is loaded after any file load to force the display config into any show. (See [Display Configuration](#)<sup>(127)</sup>)

**Merge Permanent AutoAlignment** (licenced option)

Enable this if the optional autoalignment software is installed to apply the output of that software to the display channels. Warp, Blend and Black Level Offset can be optionally enabled.

See [Autoalignment Process: Preparation](#)<sup>(206)</sup> for using Scalable Display Manager™.

**Play Startup Sequence**

This runs a selected sequence when the server starts up, after the default show is loaded and before starting to play.

**Notes**

- When permanent files are entered above, any File Load will also merge these files.
- Files are loaded in this sequence:
  - Default Show file (or any show file manually opened)
  - Permanent Show File is merged



- Permanent Display Config file is merged (background resources in first 10 frames deleted first so the warp and blends are replaced each time).
- If a Permanent Show File is loaded, then saved, it contains the contents of both files, so if then merged again, you would create duplicates.

## Default Paths Configuration

Enter default paths into this dialog:

### Default Show Path

Used in File Open / File Save dialog

### Default Record Path

Used for recording back out of Delta

### Default Mesh Path

Used for Mesh Mode OBJ file location

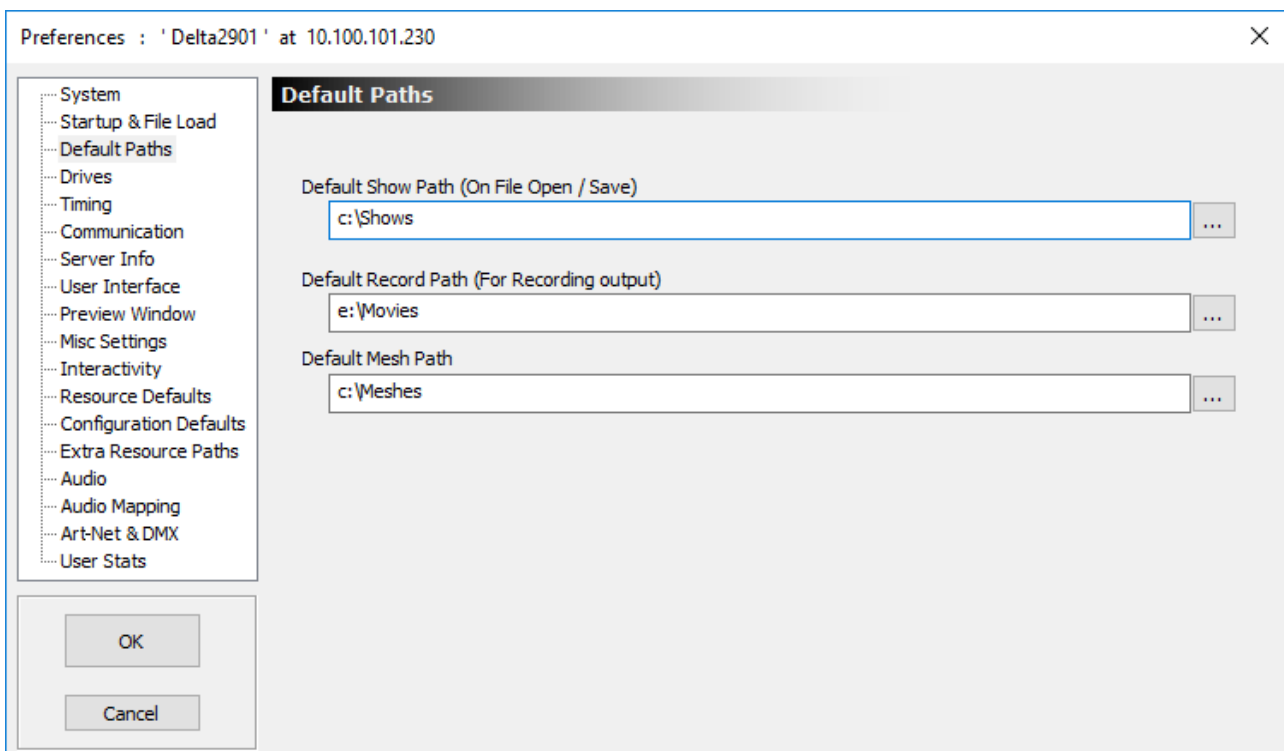

## Disk Drive Configuration

This dialog is used to configure where the server looks for Media. In the example below, the server looks for Movies on drive E: and Z: and all other media (not just images and audio) on drive C:

If you have more than one drive location where movies are held, set the other Movie Drives to point at the other locations. If you press the **Set All** button, Movie drives 2 – 6 are set to the same as Movie Drive 1.

### Reset Missing Disks to C: on Startup

If the Movie drive is not found, Delta can be set to reallocate the Movie drive to C:.

### RAID7th

RAID7th is a technique used by 7thSense to increase resilience against disk failure. In a RAID 0 array if one disk fails, the array fails. With RAID7th, frames are striped sequentially across all disks in the array, so if one disk fails only the frames on that disk are missed. In this Movie Sources tab, for servers with this type of disk format, the drives in the array are assigned as such an array. Here 4 movie drives configured as RAID7th are enabled:

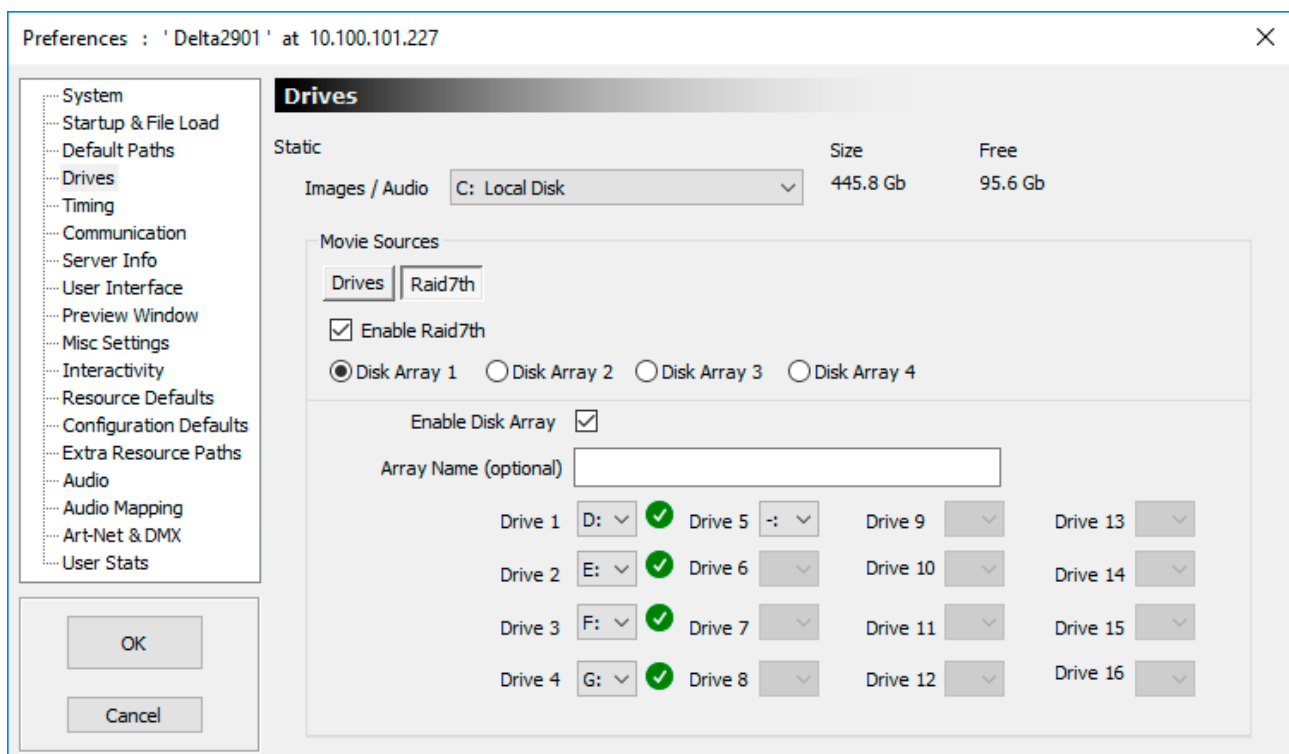

### Notes

- Movies are very disk intensive, so Delta servers are configured with fast disk drives for movies. Other content is usually stored on a separate drive to maintain the fast disk solely for movies.
- If Server and GUI are running and your resources are not found, check in this dialog where the disks are set to look.
- When you change the disk drives, DeltaServer automatically searches the drive for media, and presents this in the Resources Area.

## Timing Configuration

Configure the timing for the frame rate you require. A faster framerate gives smoother playback, but depending on the file size of the movie you are loading, you may run out of horsepower in the PC, and the framerate will not be maintained. Note also that some movies are designed for a particular framerate – playing them faster or slower may not give the intended effect.

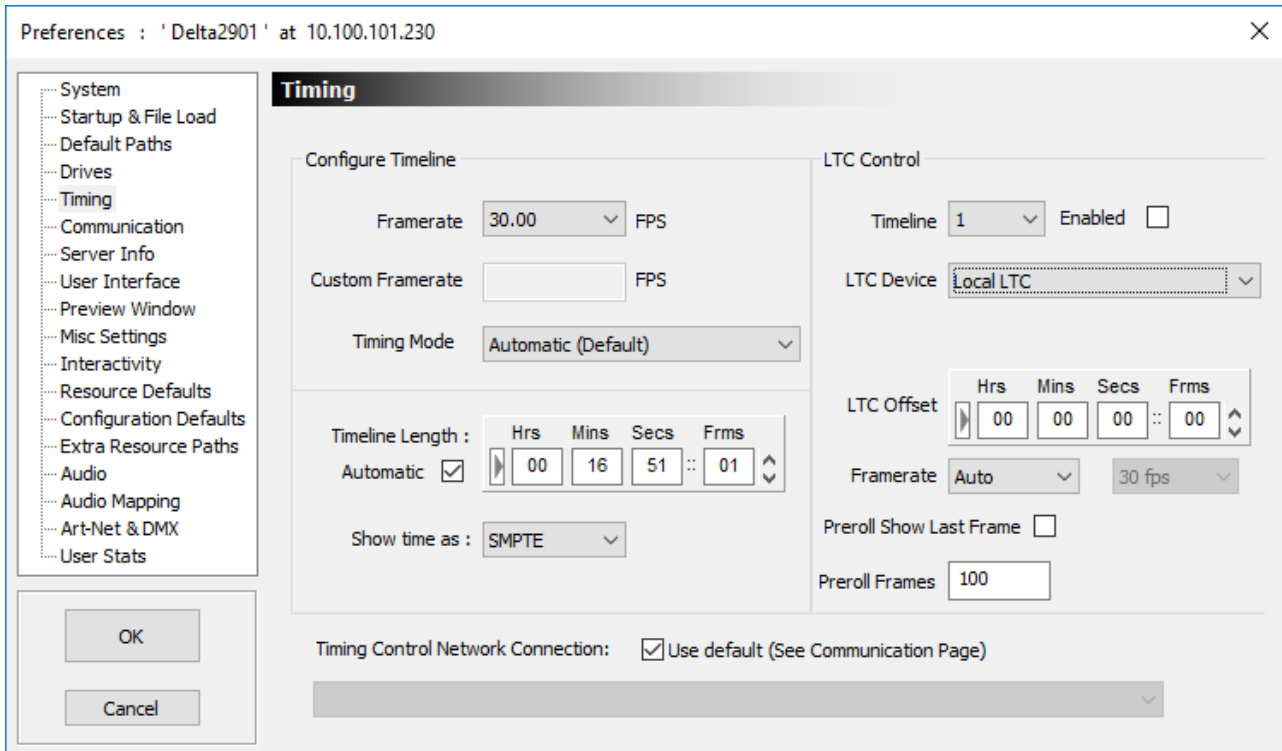

It is always better to choose a framerate at which the media does not drop frames (stutter), so if your movie cannot play steadily at (for example) 60 frames per second, drop it to the next lowest framerate (30 FPS). Alternatively, reduce the resolution of the media, or remove other parallel media in order to reduce the load.

Optimal framerates are displayed in the listbox, which are integer divisions of the graphics card framerate, so if set to 60 Hz, optimal rates are 60, 30, 20, 15, 7.5 etc.

You may want an optimal framerate of 50 FPS. To achieve this, set the graphics card monitor refresh rate to 50 Hz (using the normal Windows Display configuration dialog), and restart the server. This may require editing or adding EDID data to the graphics card. (See the DeltaMonitor User Guide.)

The Timeline Length determines what length of the timeline is controlled by the scrollbar in the Timing Area. Simply set this slightly larger than the show length or enable Automatic to auto-calculate this length.

Time can be shown as SMPTE (e.g. Hours, minutes, seconds and frames – 00:01:20:12) or Frames (e.g. 1200 frames). This is simply how the time is viewed on the Timing Area, and does not affect how the show is played.

## Timing Mode

This should normally be in **Automatic**. Other timing Modes:

### Use Hardware

Time from the internal hardware timer (graphics refresh rate).

### Use Software

Time from a software timer

### Windowed

Use this mode if timing is not constant when the playback window is non-fullscreen

### Gfx Lock

Re-syncs the GPU to hardware frame boundaries when the timeline rate is a subdivision of the VSync rate, used for example for 24 fps on a 60 Hz refresh rate, will re-sync every 5th frame (since 120 is the nearest value common to both).

### For Automation

Render will run at full rate independent of the timeline rate (so animations can run at 60 fps even with timeline rate set to 30 fps) – Note that there is significantly higher GPU load.

## Timing Control Network Connection

Choose **Use Default** (which is configured on the Communication page), or untick this option, then select the network interface for timing packets in order to separate them from the other network traffic.

## Timing Configuration – Genlocked / LTC Chase

- See [Synchronising Delta Media Systems](#) for an overview of synchronisation between show media, Delta Media Servers, display and audio devices, and other elements of show control.

In a genlocked system, LTC chasing via suitable hardware is available. This allows an external LTC audio track to directly control the playback.

**Note** that for perfect timing when chasing LTC, the LTC timecode should be synchronous with the genlock video sync. This usually means the LTC source requires a genlock signal which is also sent to the server. Even without a genlocked LTC source, the server will still chase LTC.

## Timeline

Select this and the Enabled button to set specific timelines to chase LTC.

**Enabled**

This switch is replicated on DeltaGUI in the timing area, when enabled, timeline controls such as stop, play, rewind are hidden, and external control of the playback position is enabled.

**SMPTE Device**

When available, the list of LTC input devices available is presented: select the one which will be the LTC input Leader.

**Local LTC:** Select if you're receiving LTC timecode through a standard audio input on the server. You will select this in conjunction with running LTCReader or Soundman.

**Adrielec:** Select if you're receiving LTC timecode through an Adrielec card in the server.

**Delta :** Select to choose a different Delta group to be the LTC Leader to this server. Note that this server will therefore play in sync with the Leader server from the selected Delta group.

**Sony422 VTR BlackMagic (COMX) :** Select to receive LTC from the RS422 input of a BlackMagic SDI card.

**Sony422 VTR Bluefish :** Select to receive LTC from the RS422 input of a Bluefish SDI card.

**CSony422 VTR (com78) :** Connect to a Sony protocol LTC device on com78.

For all options apart from Delta, there are options for Framerate : Auto, Drop or Non Drop and Drop and Non Drop can choose 60, 30, 29.97, 25 or 24 fps rates.

**SMPTE Offset**

Since there is no negative time in the LTC timecode, many LTC audio tracks start at 59mins, 50 secs, which allows a 10s preroll, and the show starts at 1 hour. The LTC Offset allows you to type in 59 min, 50s, which will be subtracted from the incoming timecode which means the Delta content can start at 0 time on the timeline.

**Incoming Rate**

This is the LTC timecode rate read from the LTC Input Device.

**Preroll Show Last Frame**

During the preroll period, show the last frame rendered instead of black.

**Preroll Frames**

The number of frames to preroll before showing the content.

## Communication Configuration

### Serial Ports

Up to 32 serial com ports can be configured, even if there are fewer than that installed in the machine, allowing you to configure and save COM port details to a file for a different server.

A COM port will show up in the Baud/Parity/Data and Stop columns if it is present on that server. If a different application to Delta has grabbed that COM port, it will be listed as Taken.

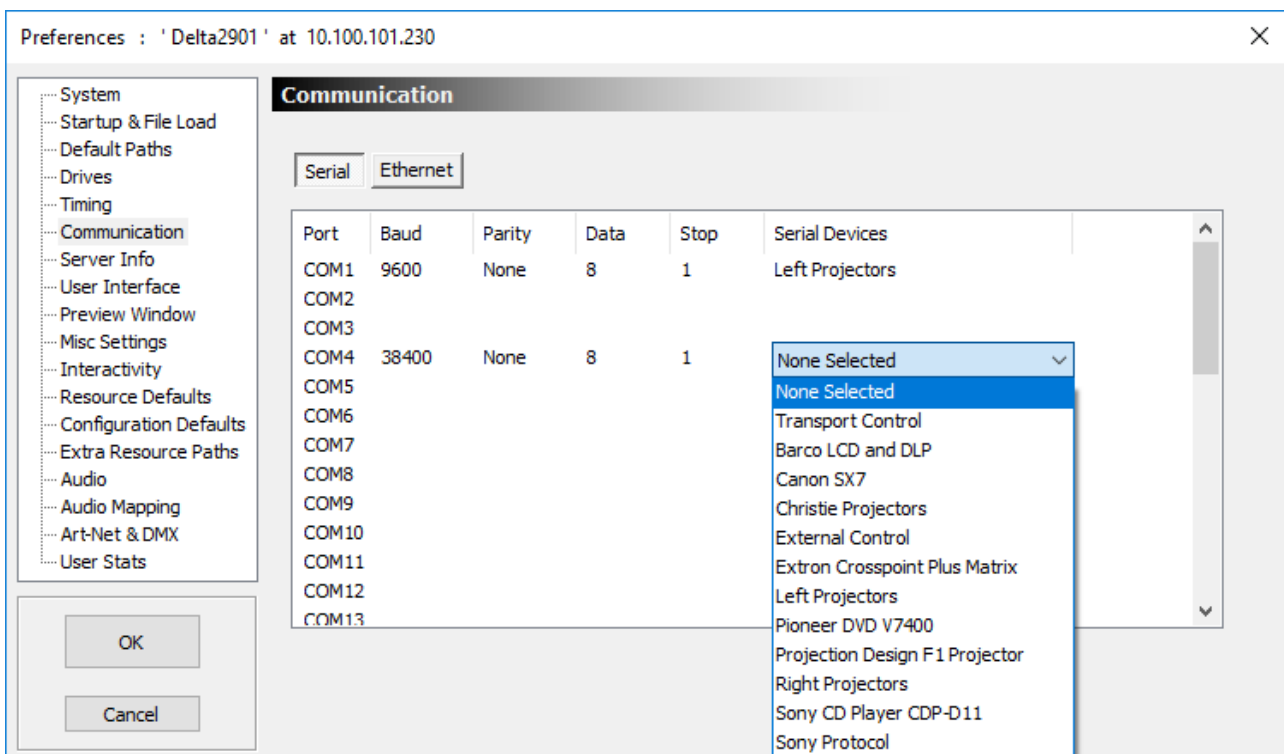

Choose the COM port parameters to match the external device, and then the device from the Serial Devices list. This list contains those devices found in the `\SerialEvents` folder as well as external and transport controls

External Control and Transport Control are saved in the PC (in the registry), all other com port devices are held in XML files. If a file contains serial devices which conflict with existing external or transport control com ports, the file devices are ignored.

This means External or Transport controls, once configured, are available from start-up with no additional interaction. This allows external controllers to immediately load a show.

### Communication Timeout (set in the small DeltaServer dialog)

In some networks, the comms can be unreliable, leading to the situation where the network dies, leaving the server still thinking it's connected to DeltaGUI. A server application restart is required to fix this. The same can be true of communication from external control systems over Telnet.

To fix this, enable the DeltaGUI Comms timeout or Telnet timeout in the **server's** communication dialog:

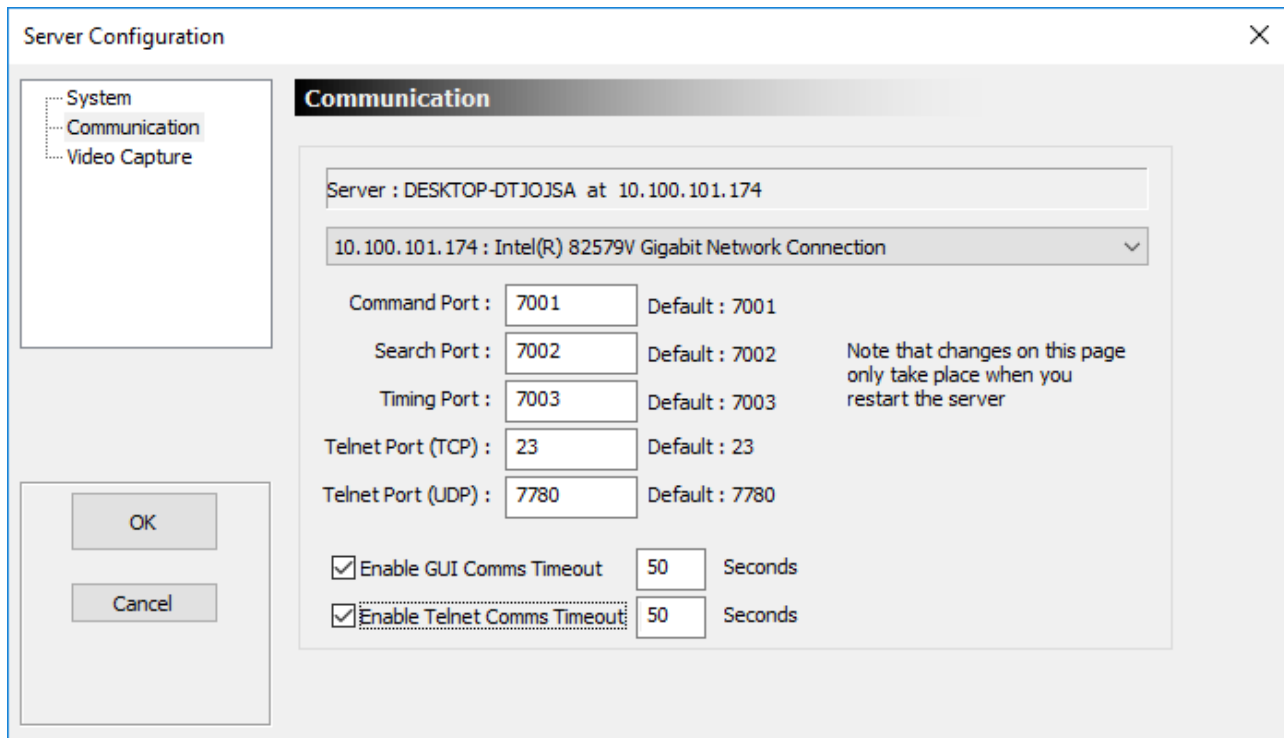

Set the timeout value in seconds, and if the Telnet is inactive (no characters received from the control system) in 50s in the example above, the Telnet connection is dropped, allowing the control system to reconnect.

DeltaGUI operates on a heartbeat system, so if the Server detects the heartbeat from DeltaGUI missing for 50s (in the example above), the connection is reset, allowing DeltaGUI to reconnect if the network has come back.

### Ethernet Configuration

In this dialog, you can configure over which ports DeltaGUI talks to the server, and the external control port for Telnet. The defaults for Delta are:

Command Port	7001
Search Port	7002

Timing Port	7003
TCP External Control	23
UDP External Control	7780 (response from Delta on 7781)

These can be changed to any normal port if DeltaGUI is configured to have the same ports as the server.

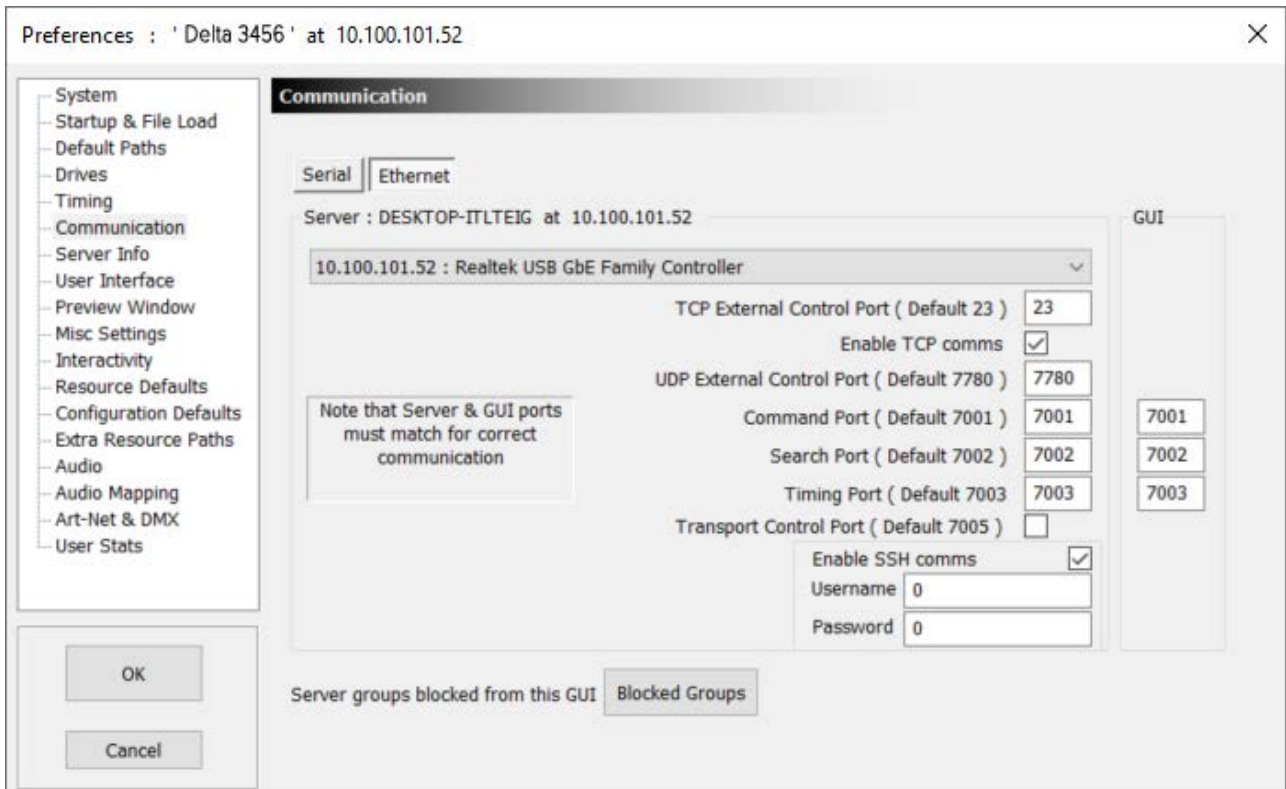

In systems with multiple active Ethernet ports, you can choose which one the server will use with the drop-down box. Note that disabled Ethernet ports do not show up in this dialog, and that the IP address shown for each port is that configured at the time; with DHCP enabled, this may change in the future, though the server will use whatever the IP Address is at the time the server starts.

The Ethernet external control port defaults to 23 (TCP / Telnet) and 7780 (UDP), although this can be any port which is not already used. A standard Telnet client can connect to the server, even if playing, and be controlled through the external control protocol.



## Secure Communications – from Delta 2.7 build 7

For secure communications, e.g. using PuTTY, SSH can be enabled, with a username and password.

### Blocked Groups

If the dialog is cleared, this instance of DeltaGUI will accept connections from all servers found on the network. In some cases, you may want 2 or more instances of DeltaGUI to controlling different groups of servers.

You can also choose between showing the standard 20 or the maximum 64 groups in the server drop-down here.

Blocked Groups

Groups which are checked will be blocked from this GUI. (Restart GUI to see changes)

Blocked Groups

<input checked="" type="checkbox"/> 1	<input checked="" type="checkbox"/> 2	<input checked="" type="checkbox"/> 3	<input checked="" type="checkbox"/> 4	<input checked="" type="checkbox"/> 5	<input checked="" type="checkbox"/> 6	<input checked="" type="checkbox"/> 7	<input checked="" type="checkbox"/> 8	<input checked="" type="checkbox"/> 9	<input checked="" type="checkbox"/> 10
<input checked="" type="checkbox"/> 11	<input checked="" type="checkbox"/> 12	<input checked="" type="checkbox"/> 13	<input checked="" type="checkbox"/> 14	<input checked="" type="checkbox"/> 15	<input type="checkbox"/> 16	<input checked="" type="checkbox"/> 17	<input checked="" type="checkbox"/> 18	<input checked="" type="checkbox"/> 19	<input checked="" type="checkbox"/> 20
<input checked="" type="checkbox"/> 21	<input checked="" type="checkbox"/> 22	<input checked="" type="checkbox"/> 23	<input checked="" type="checkbox"/> 24	<input checked="" type="checkbox"/> 25	<input checked="" type="checkbox"/> 26	<input checked="" type="checkbox"/> 27	<input checked="" type="checkbox"/> 28	<input checked="" type="checkbox"/> 29	<input checked="" type="checkbox"/> 30
<input type="checkbox"/> 31	<input checked="" type="checkbox"/> 32	<input checked="" type="checkbox"/> 33	<input checked="" type="checkbox"/> 34	<input checked="" type="checkbox"/> 35	<input checked="" type="checkbox"/> 36	<input checked="" type="checkbox"/> 37	<input checked="" type="checkbox"/> 38	<input checked="" type="checkbox"/> 39	<input checked="" type="checkbox"/> 40
<input checked="" type="checkbox"/> 41	<input checked="" type="checkbox"/> 42	<input checked="" type="checkbox"/> 43	<input checked="" type="checkbox"/> 44	<input checked="" type="checkbox"/> 45	<input checked="" type="checkbox"/> 46	<input checked="" type="checkbox"/> 47	<input checked="" type="checkbox"/> 48	<input checked="" type="checkbox"/> 49	<input checked="" type="checkbox"/> 50
<input checked="" type="checkbox"/> 51	<input checked="" type="checkbox"/> 52	<input checked="" type="checkbox"/> 53	<input checked="" type="checkbox"/> 54	<input checked="" type="checkbox"/> 55	<input checked="" type="checkbox"/> 56	<input checked="" type="checkbox"/> 57	<input checked="" type="checkbox"/> 58	<input checked="" type="checkbox"/> 59	<input checked="" type="checkbox"/> 60
<input checked="" type="checkbox"/> 61	<input checked="" type="checkbox"/> 62	<input checked="" type="checkbox"/> 63	<input checked="" type="checkbox"/> 64						

Select All Clear All

Show all 64 groups (standard is 20 groups) Done

## Server Information

The server information tab shows hardware configuration information gathered from the current server.

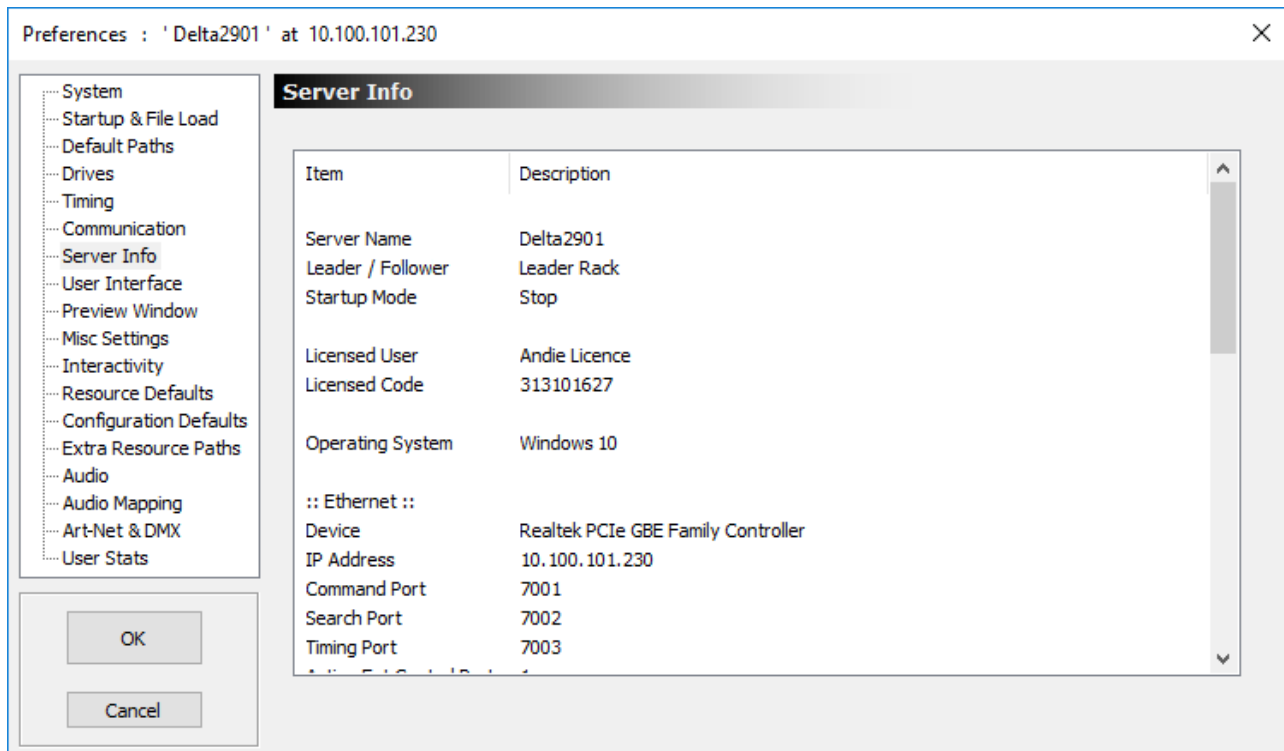

## DeltaGUI User Interface

This dialog allows you to tune DeltaGUI preferences.

## Graphics

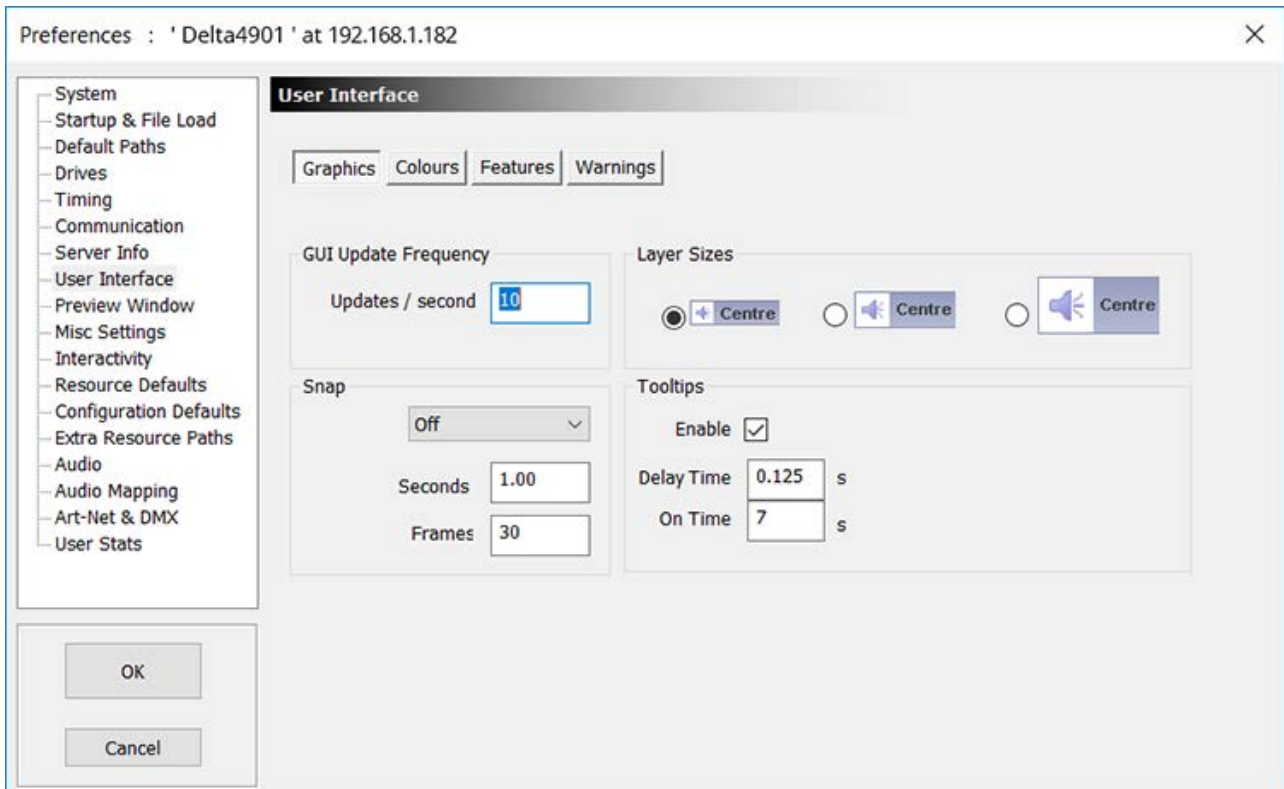

### GUI Update Frequency

In updates per second, the frequency with which the layers are redrawn. For a low performance machine, you may need to lower this to 10 updates /second, for higher performance machines, 20 or 30 is preferable.

### Snap

This enables and configures the layer snap grid. When showing Frames, the snap is set to 30 frames in the example above, when viewing SMPTE, the snap is set to 1 second in the example above. You can also snap to the end or start point of other resources on the same layer by turning on *Snap > Grid and Resources*. Note you can also access the snap menu from the status bar at the bottom of DeltaGUI.

### Layer Sizes

Choose from small, medium or large layer heights in the Timeline

These items are remembered locally on the DeltaGUI PC.

## Colours

These are the default colours for layer items when selected, disabled or when they have errors. These can be tuned to your preferences; they are stored in the registry.

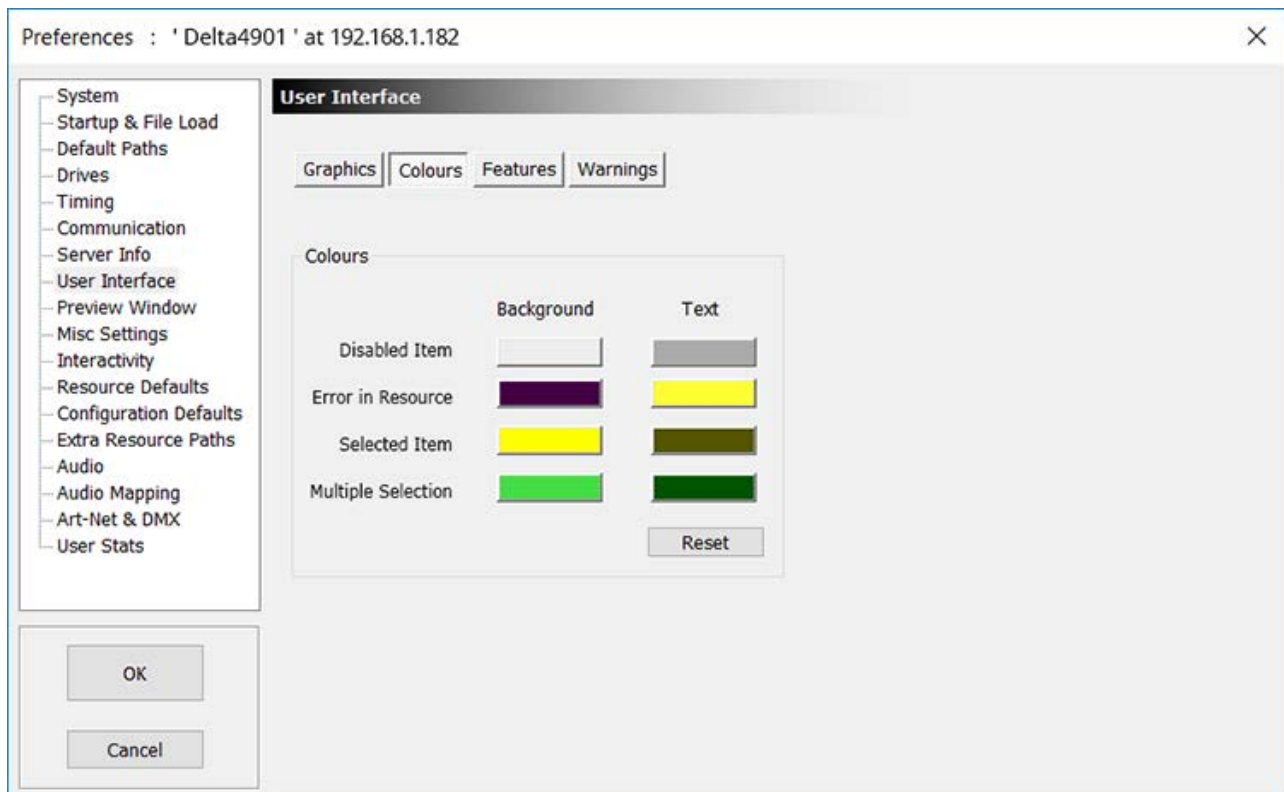

## Features

This dialog page allows the user interface to be customised:

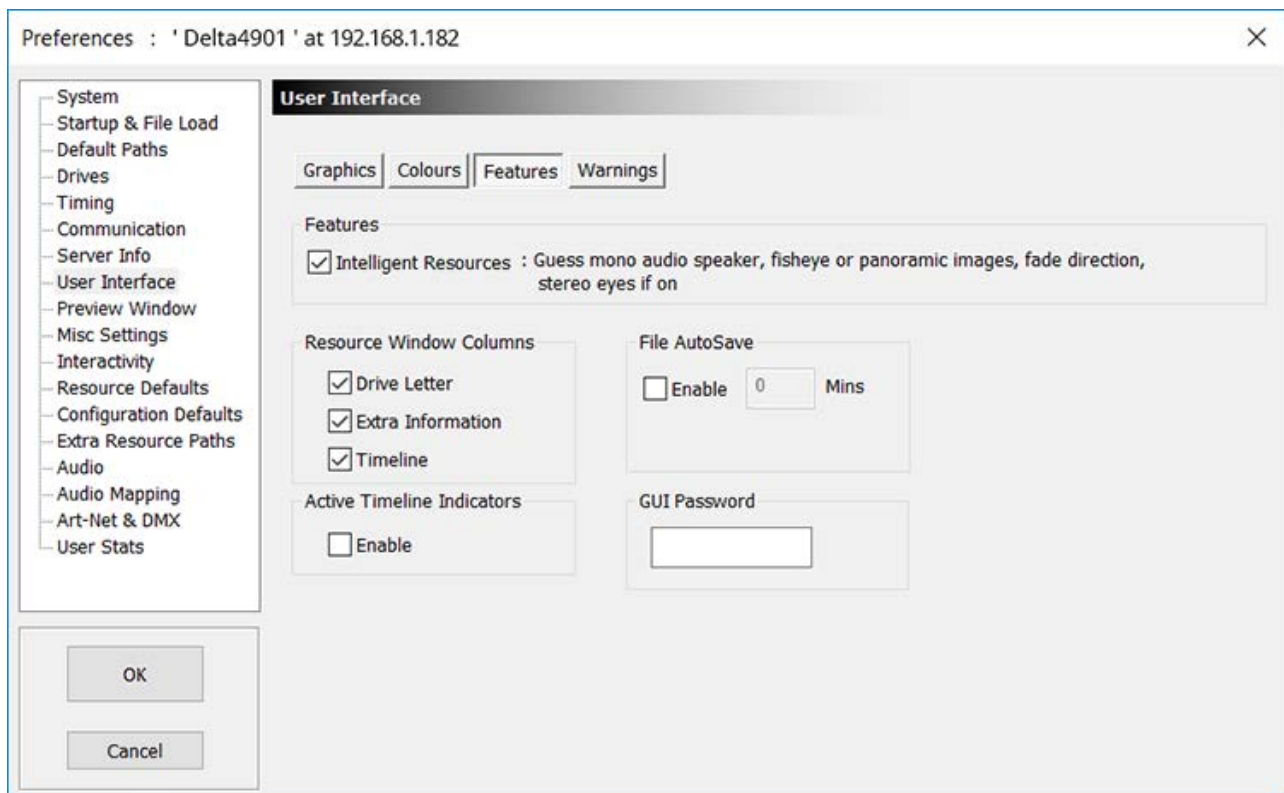

### Resource Window Columns

In the resource window (left side of DeltaGUI), you can have optional columns showing the drive letter, extra information such as image size or audio format or which timeline a resource is on for timeline resources.

### Active timeline Indicators

The timeline play and autoplay indicators in the bottom status bar default to being simply LED indicators – if you enable this checkbox, those LEDs become toggle switches to play/stop each timeline or autoplay state.

### AutoSave

Saves this server's current file at the specified interval (if not playing a show).

### GUI password

Type in a password which will be requested any time DeltaGUI is started. Note that this password is stored in plain text in the registry.

### Intelligent resources

If enabled, a set of behaviours is added which help minimise time to create a show: These are only used when you add a new resource to the timeline, they do not affect existing resources on the timeline.

Media	Media Format (Mono Audio Files)	Display Mode	Automatic Parameter
Image or Movie	Square and 1500 x1500 or larger or Square and has 'fisheye' in filename	Dome (Frustum)	Fisheye mapping
Image or Movie	Aspect ratio > 2.5 and width >=1500 or Aspect ratio > 2.5 and has 'panoramic' in filename	Dome (Frustum)	Panoramic
Back Surface Projection	If the projectors are on the outside of the dome and the software is set to draw on the back surface, in Dome mode, visual resources will be placed on Mirrored horizontally	Dome (Frustum)	Mirror
Image or Movie	Filename has _L or _left on the end Filename has _R or _right on the end	Stereo	Left eye Right eye
Audio	Mono audio and filename is or ends in: L or left or 1 or ch1 R or Right or 2 or ch2 C or Centre or Center or 3 or ch3 Ls or leftsurround or 4 or ch4 Rs or rightsurround or 5 or ch5 LFE or Sub or 6 or ch6 Lside or rearleft or rl or leftback or 7 or ch7 Rside or reارئ or rr or rightback or 8 or ch8 9 or ch9 10 or ch10 11 or ch11 12 or ch12 13 or ch13 14 or ch14 15 or ch15 16 or ch16	Any	Speaker: Left Right Centre Left Surround Right Surround Sub Left Side Right Side Output 9 Output 10 Output 11 Output 12 Output 13 Output 14 Output 15 Output 16
Fade	Choose up or down to be opposite from previous up or down fade / transparency	Any	Direction

## Warnings

### File Modified

If the file has changed by editing the timeline, and you attempt to load a file or do File New, a warning dialog will pop up.

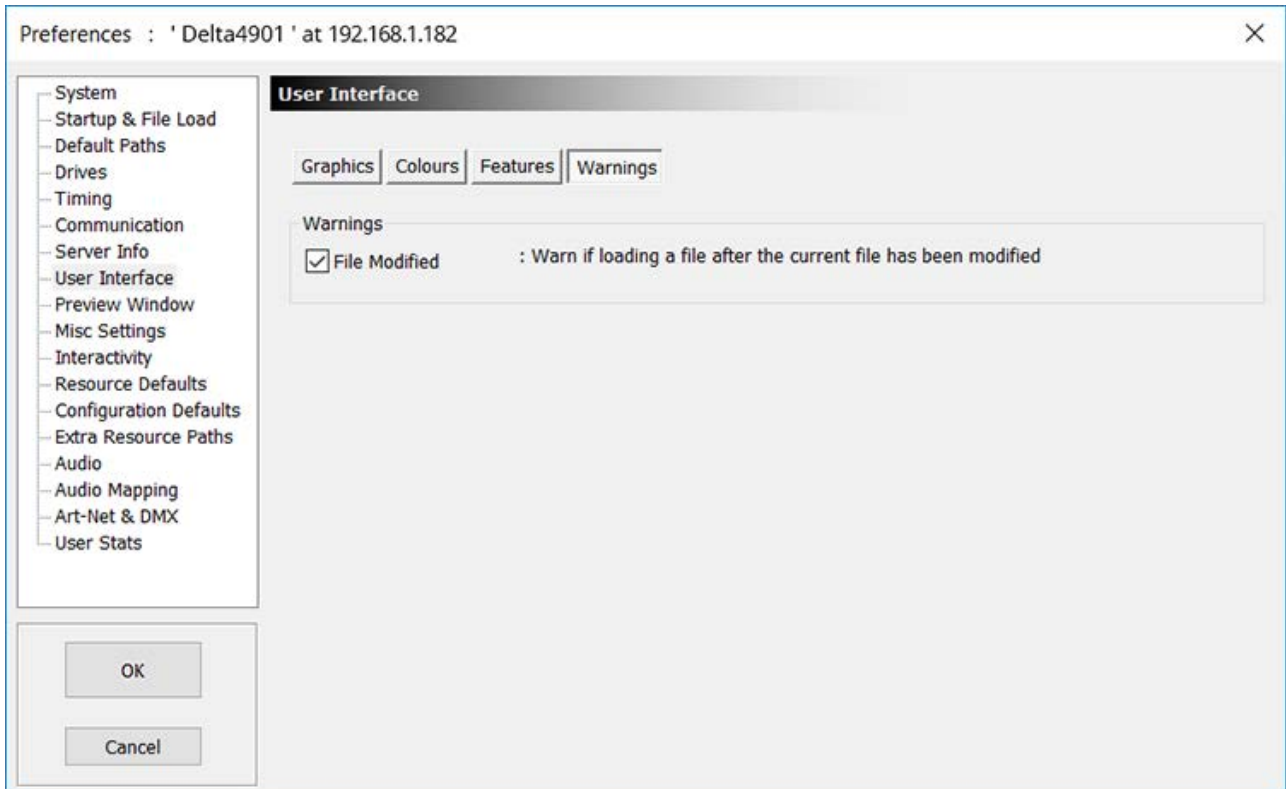

## Preview Window / Record Preview setup

This dialog allows you to set the resolution of a hardware preview card (if fitted) or preview recording output format. Note that larger resolutions create a larger load on the server and DeltaGUI.

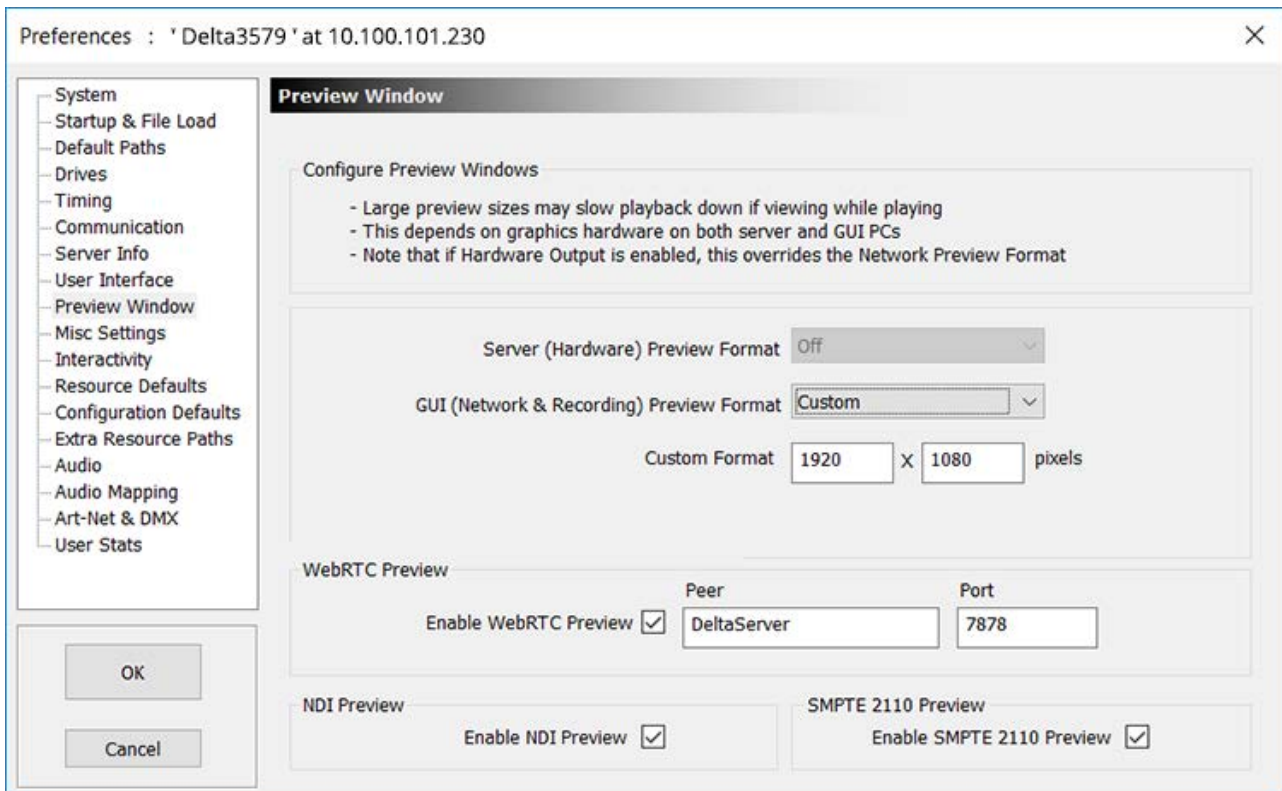

### Server (Hardware) Preview Format

If preview output hardware is fitted to the server (can be HDMI, SDI etc.), this drop-down allows configuration of the available output video format.

### GUI (Network and Recording) Preview Format

Select one of the standard output formats or Custom, and type in the custom Width x Height in pixels. This format will be used when Real-time (Preview) Recording is activated either from the [Recording dialog](#)<sup>419</sup> or external control. This also affects the fit of show preview in the web Preview browser page.

**Note:** Real-time (Preview) Recording is controlled from external control or a sequence using the REAL-TIME\_RECORD, REAL-TIME\_RECORDSETTINGS, REFRESHMOVIE and DELETE\_DISKMEDIA commands.



## WebRTC Preview

### Enable WebRTC Preview

The streaming preview to web browsers can be enabled here, and the Peer Name and Port set – this requires a Delta Web Service / Signalling Server to be running.

➤ [Viewing and Previewing Shows](#) <sup>414</sup>

## NDI® Preview

### Enable NDI Preview

Check this for Network Device Interface (NDI®) preview. Note that the NDI preview size is that shown in *Display > Preview Setup > Canvas Size*. Your NDI monitor will detect your server IP for selection and viewing. Other settings will depend on which NDI monitor you are using.

## SMPTE 2110 Preview

### Enable SMPTE 2110 Preview

Check this is you are using SMPTE 2110. Initially only 1920 × 1080 10-bit 4:2:2 is supported.

## Misc Settings

This dialog allows configuration of some miscellaneous features:

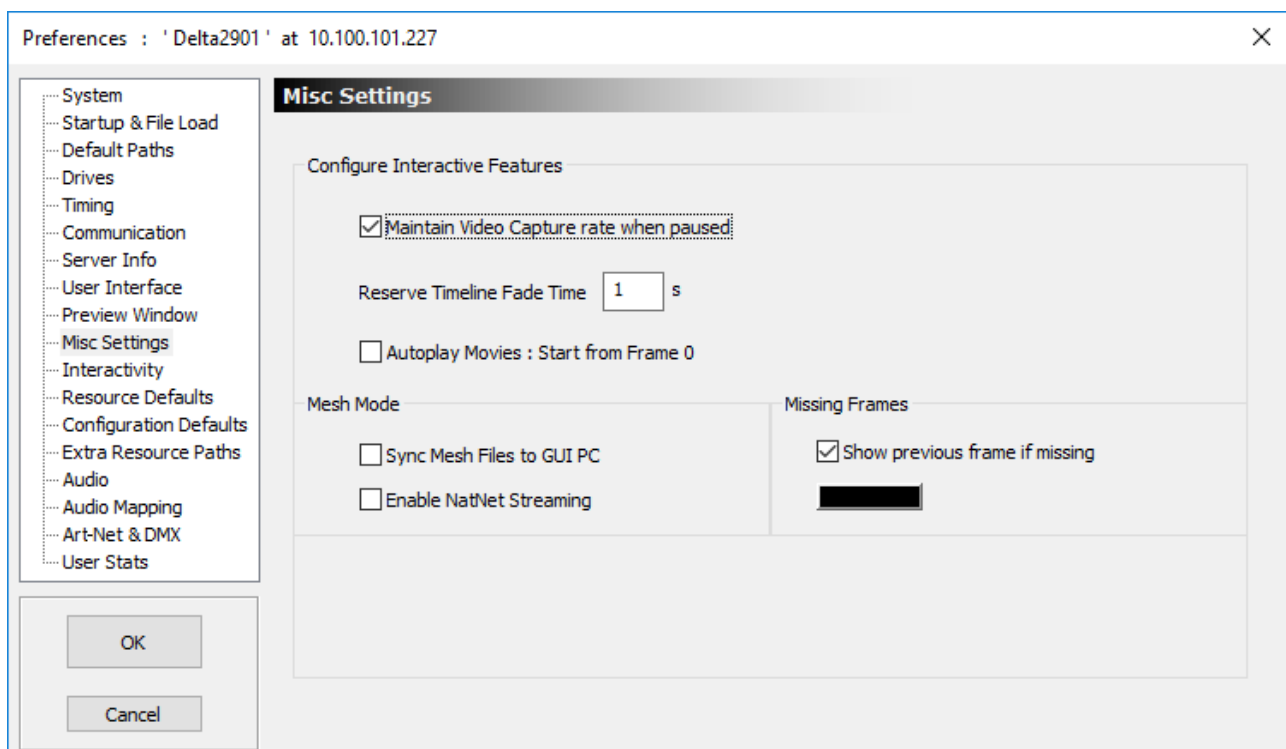

**Maintain Video Capture rate when paused**

If cleared, any video capture windows shown on the timeline when not playing will drop to 1 frame per second to free up CPU.

To keep the video capture at full rate when not playing, tick this box.

**Reserve Timeline Fade Time**

Sets the time in seconds to fade from Reserve to normal operation.

**Autoplay Movies**

Start from frame 0: When enabled, whenever the playhead moves into a movie set to autoplay, it will always restart the movie at frame 0. When this is not selected, the movie will restart from the previous frame it stopped on.

**Sync Mesh Files to GUI PC**

When enabled, on any load, save or startup of DeltaGUI or DeltaServer, DeltaGUI will check if the mesh files locally on the DeltaGUI PC match the server's list and upload missing or modified meshes to DeltaGUI.

**Enable NatNet Streaming**

Used for [Optical Tracking Mesh Mode](#) <sup>(269)</sup> Mesh Mode with OptiTrack Motive systems.

**Missing Frames**

Choose to repeat the previous frame if a frame is missing, or choose the colour (default black) for a blank frame.

## Interactivity

---

This dialog allows the global configuration of direct interactivity with the Delta playback window. When enabled and the resources are also configured to be Selectable or Movable, a user can directly move or trigger sequences by clicking on the resource on the playback window, or with Windows 7 or 10 Gestures enabled (see below), drag resources around the playback window.

This is used in for example museum kiosks where the only user interface is the output of the server itself – the playback window can have image or movie resources which act as buttons which alter the show, such as play/stop or select different media.

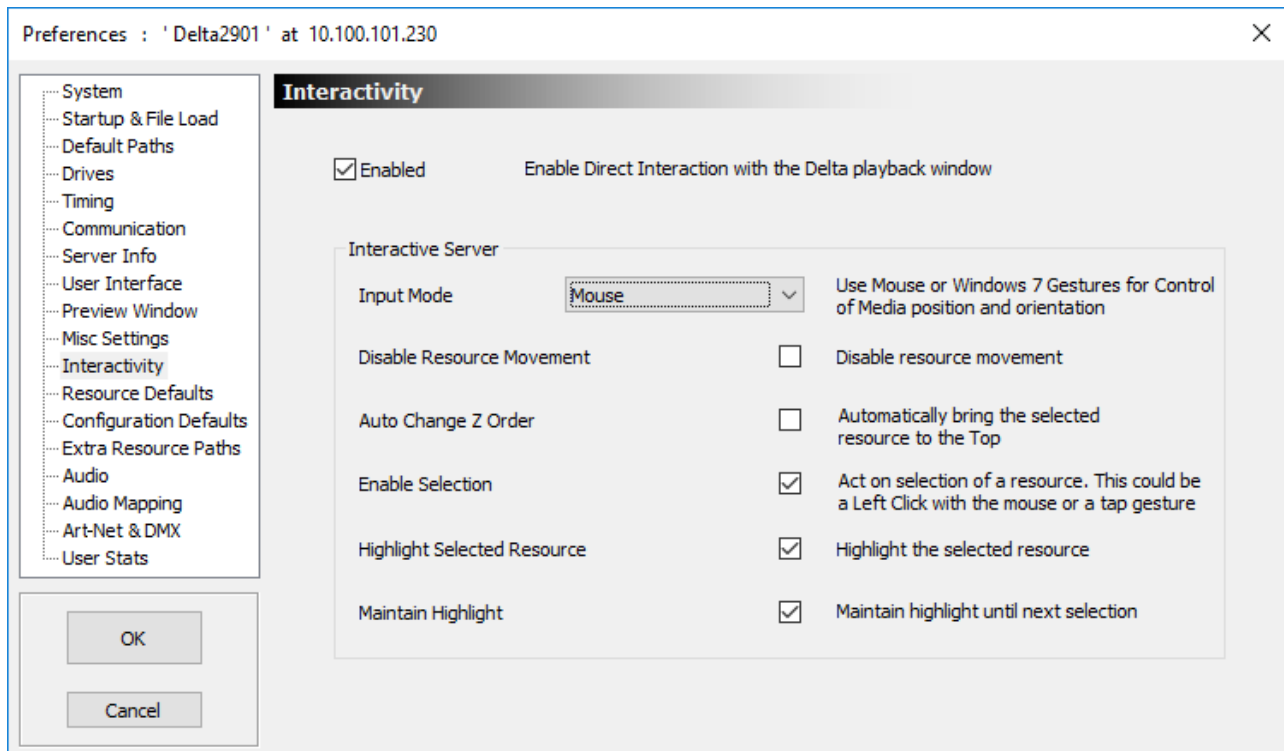
**Enabled**

Enable or disable interaction on the playback window.

**Input Mode**

None, Mouse or Gestures

**Disable Resource Movement**

Select this so that even if resources are set to Movable, do not allow any movement of resources.

**Auto Change Z Order**

If enabled, when you click on a resource, it will be placed at the top of the Z Order so you can see it.

**Enable Selection**

If enabled, trigger on a click or tap – this triggers the OnSystem\_ResourceSelect system sequence, sending in the resourcename, external control name and X and Y location of the click. You can then write a sequence to do anything in the server.

**Highlight Selected Resource**

Draw a moving marquee around the selected resource

**Maintain highlight**

Keep the moving marquee on the previous resource.

**Note:** this is configured on each resource independently, so you have to enable Selection or Movement on the resource for it to move or trigger the OnSystem\_ResourceSelect sequence.

## Resource Defaults

This dialog allows configuration of the defaults applied to a resource when you add a new one to the timeline:

In Flat plane or Stereo, the left-hand column defines the position and size of the new resource, in Dome mode, the right hand column defines the position, size and mapping mode of the new resource.

If **Force W & H** is checked, the width and height of the new resource is forced to the values in the W and H edit boxes. If not checked, the width and height are left as the resource defaults from the image or movie.

You can turn off these defaults by un-checking the **Use Defaults** checkbox.

You can also copy these defaults to the group by clicking **Copy To Group**.

### Audio – Guess Mapping Preset

If enabled, the speaker mapping logic will attempt to guess the Audio Mapping if any which matches the resource name. You can edit those mappings in the Audio mapping section below.

## Configuration Defaults

This dialog allows the server to be set in Show Mode (or partially in Show Mode) where certain parameters from a show XML are ignored.

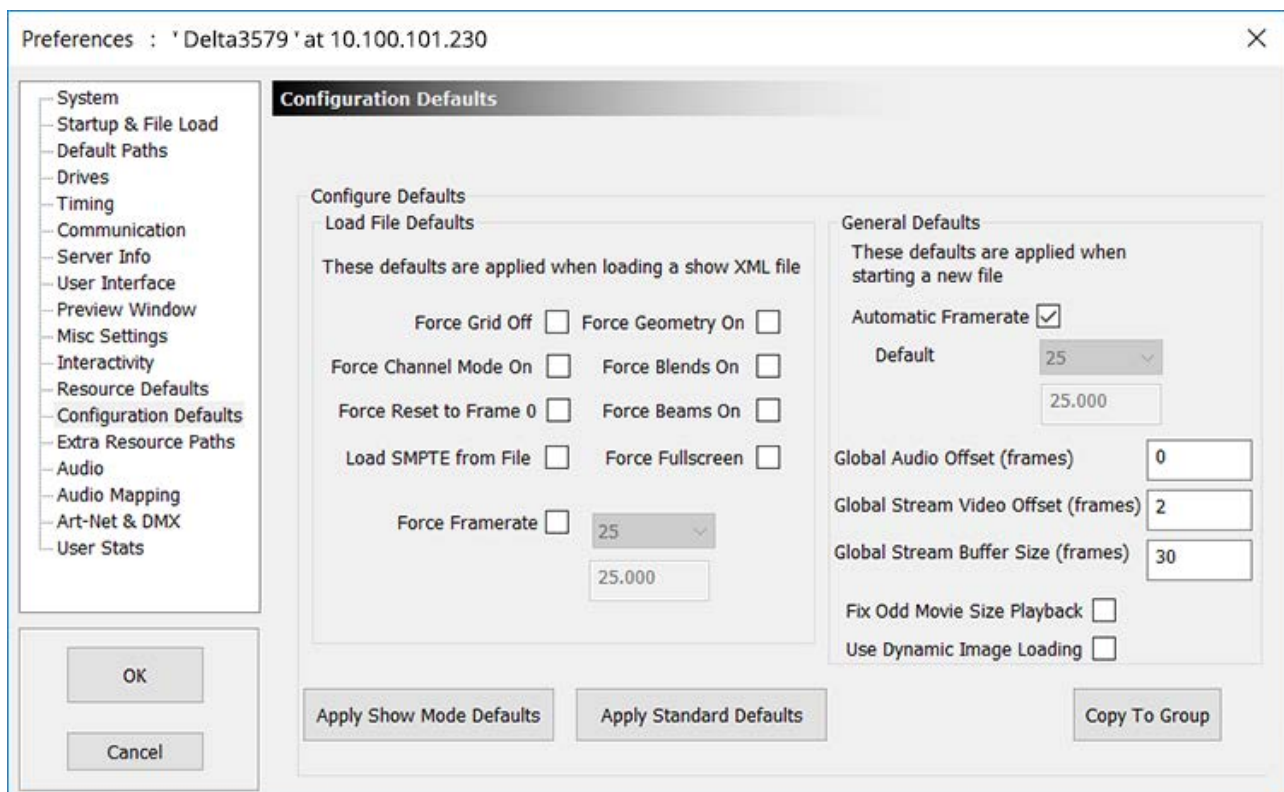

This allows, for example, a server to always override the XML settings for grid, beams, geometry to ensure that these are always turned to the most suitable setting for a show, so that the audience never sees the grid and the beams are always forced on.

Pressing the **Apply Show Mode** defaults turns on all of the options, **Standard Defaults** turns them off.

In addition, if the **Automatic Framerate** is not checked, you can force the default framerate when File New is chosen instead of having the server guess the framerate from the refresh rate.

Load SMPTE from File – the state of SMPTE slaving when the file is saved is ignored unless this box is checked.

**Global Audio Offset (frames)**

offset all audio files on the timeline by this amount of frames (positive or negative) in order to easily fix lipsync problems if all audio is mismatched by the same amount. This could also be achieved by moving each audio file on the timeline.

**Global Stream Video Offset (frames)**

offset all streaming video by this number of frames.

**Global Stream Buffer Size (frames)**

increase the streaming video buffer size.

**Use Dynamic Image Loading**

With this option off, Delta will load all still image files into RAM when a show is loaded for instant access when scrubbing on the timeline or during playback. If the total amount of RAM used by the show exceeds physical RAM in the server, this option will fail to load all images.

With this option on, all images are not loaded into RAM, but streamed as they come into scope on the timeline, so that they appear on the correct frame as normal. When scrubbing around on the timeline (not playback), there may be a short delay before they appear due to this option.

**Fix Odd Movie Size Playback**

For legacy graphics drivers, tick this to improve performance when the movie width is not evenly divisible by 4. Odd sizes may not run or run badly. Bad dimensions will generate an alert in the Resource Pool. See [Media Management for Delta Servers](#).

## Extra Resource Paths

---

The standard resource paths (e.g. E:\Movies for movies, C:\Images for images) can be extended to your own paths, so that you could add a path for each resource type, for example in these path trees:

C:\MyProjects\Projects2009	\Movies
	\Images
	\Audio
C:\MyProjects\Projects2010	\Movies
	\Images
	\Audio

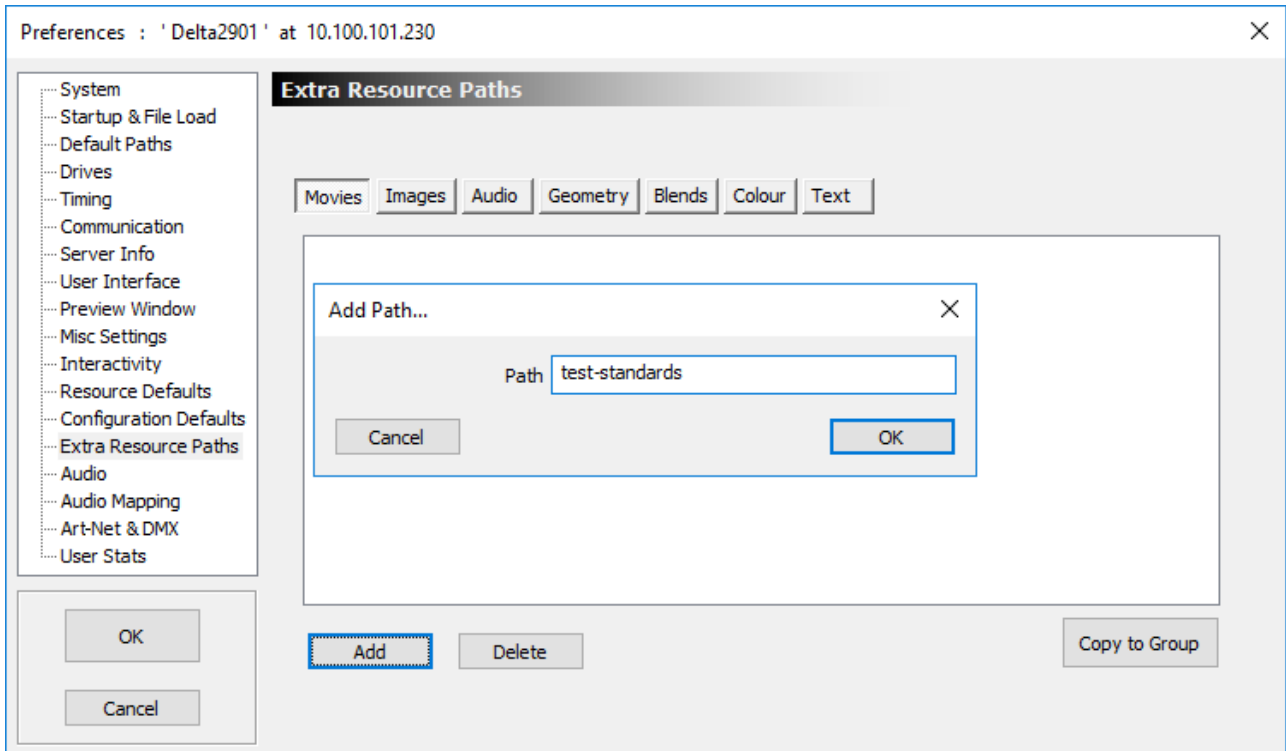

Note that movies are usually held on a different, faster disk.

You can cycle between the standard paths and extra resource paths by pressing this button:

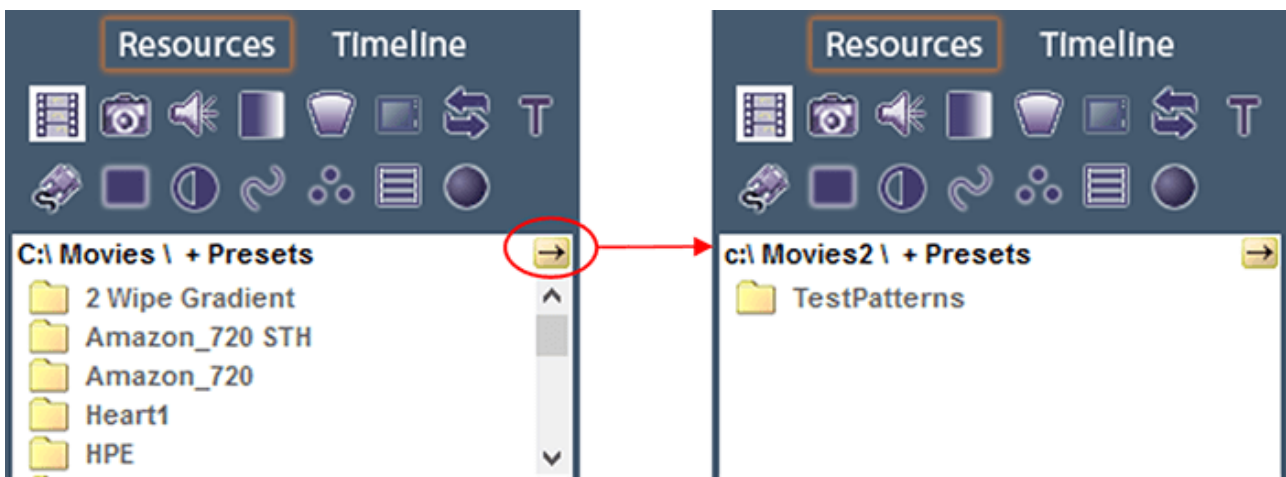

After clicking on one of the paths in the resource folder area, you see only those resources in the main resource window below.

## Audio Type

You can choose to use a Windows (DirectShow) based audio device or ASIO device in this page. If there are any ASIO devices present, you can select ASIO and then the particular ASIO device if there are multiple present.

You can also choose to autodetect the number of audio channels or force the number (some audio devices need this, as they do not report the correct number of channels).

## Forcing channels

- If you force a number of channels that the device does not support, it will fail, so the number reported in the Stats will be 0 and there will be no audio.
- If you have a device that supports more channels than you are only using, do not force the lower number. There is no need, and some devices will not function properly as a result.

**Note:** After changing any settings in this page, you will need to restart the server application.

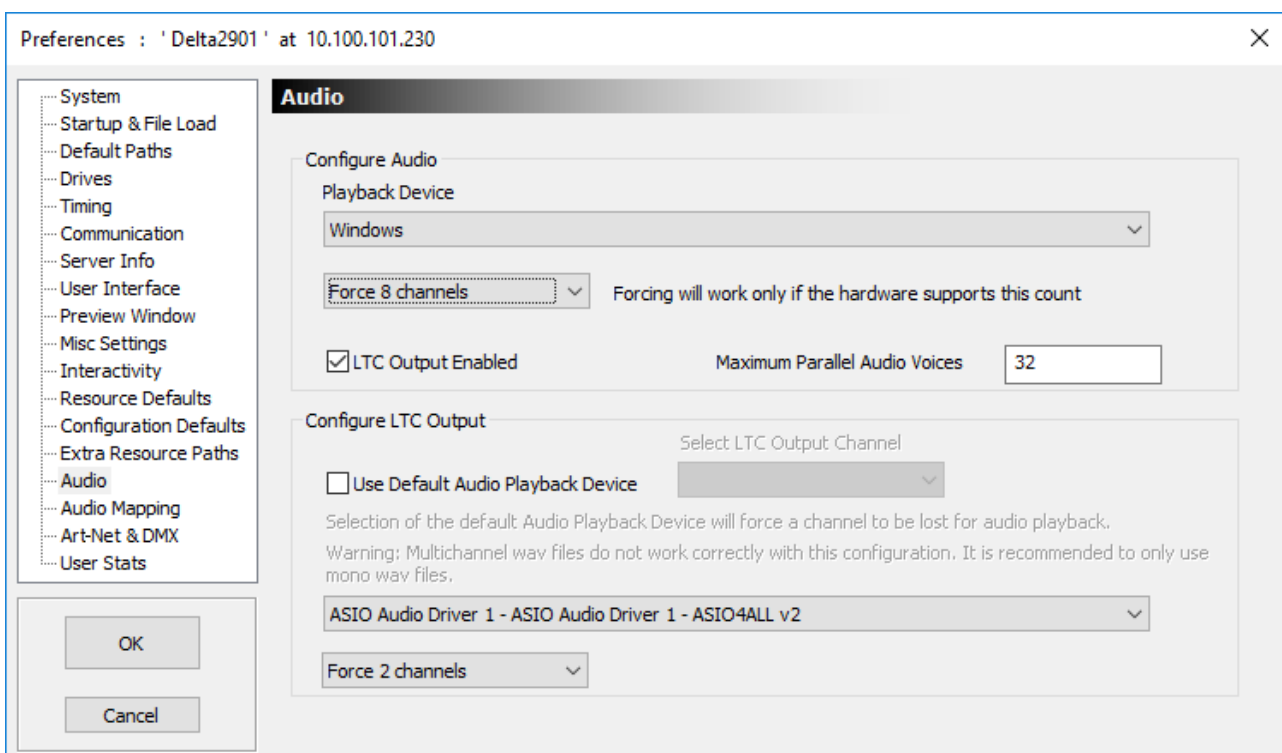

## Maximum Parallel Audio Voices

Default of 32, this sets the maximum number of simultaneous audio tracks which will be heard. Note that audio resources which are butted together on the timeline will both count for a period of time, so if you have 8 tracks followed by 8 immediately, this counts as 16 for the period near both sets of tracks.



### LTC Output Enabled

With this option enabled, a channel from the default audio device (see Use Default Audio Playback Device) is reserved for LTC output, making it unavailable for normal audio playback. You can now edit an audio track's properties and choose LTC Track on the Audio Levels page so that this audio track is sent out via the previously-configured LTC audio output only.

### Select LTC Output Channel

Choose which of the available audio channels is selected as the LTC output channel as described above, making it unavailable to normal audio output.

If Use Default Audio Playback Device is deselected, you can select another audio device (if present in the system) to output LTC audio using the dropdowns at the bottom of the page.

### Example audio resource editor showing it set as an LTC track

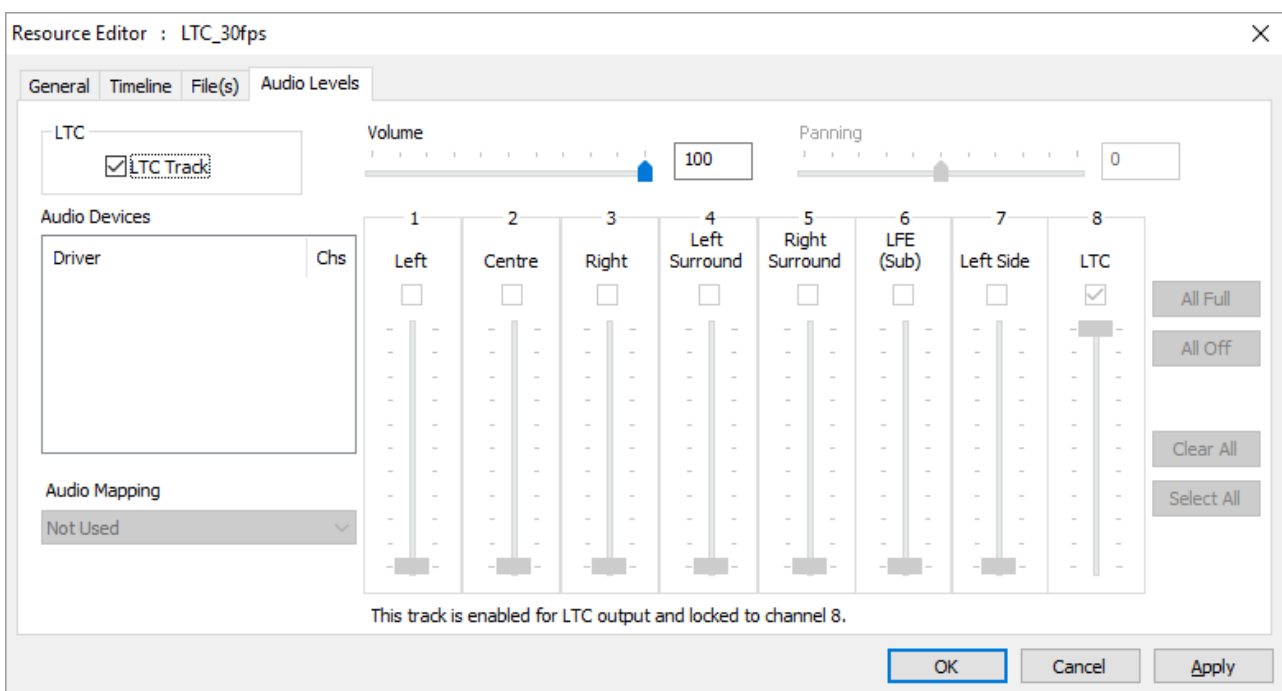

## Audio Mapping

Audio mappings are a way of pre-configuring a quantity of audio channels, which output audio channels and channel volumes so that instead of having to edit each audio resource, you configure the mapping once, and apply it to the resource.

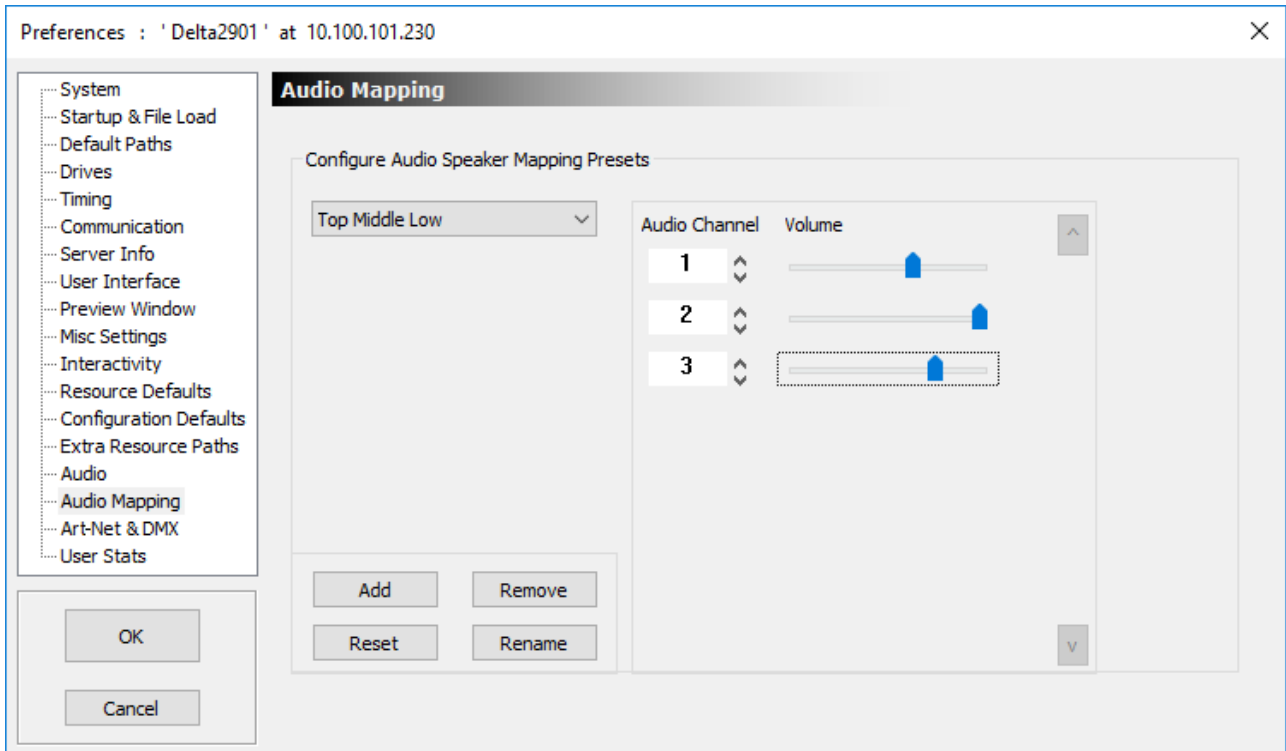

In the above example, 'Top Middle Low' is a user-created audio mapping which has been created with 3 channels, numbered 1, 2 and 3 with pre-set volume levels. In the audio resource editor shown below for an audio file, you can choose to have Not Used for audio mapping (to edit the channels and volumes as normal), or select the 'Top Middle Low' audio mapping from the audio mapping dropdown.

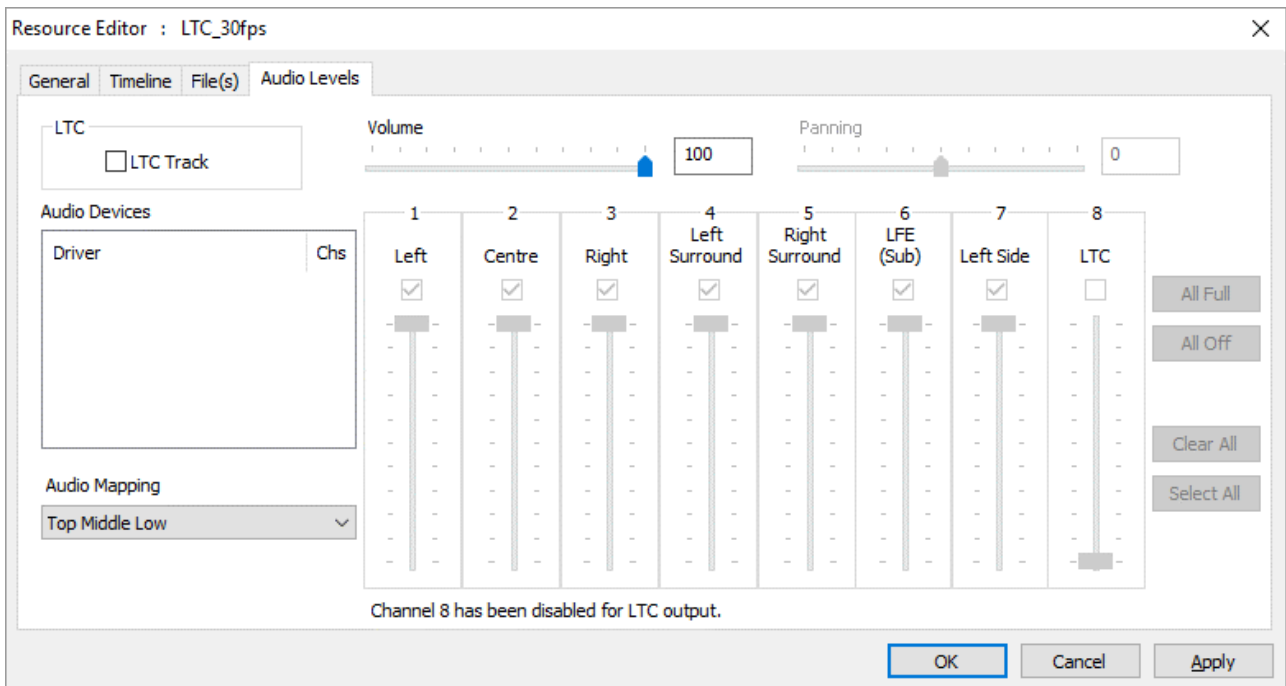

**Note** that some audio mappings (named CH1 – CHX) are built in and cannot be deleted, but you can add your own audio mappings as well with specific channel counts.

## AudioMapper

Custom audio mapping files can be generated in JSON format using the AudioMapper utility, installed with Delta 2.6.69 and later. For users of Delta 2.5.33, custom audio mapping has been available. If you want the utility, contact [support@7thsense.one](mailto:support@7thsense.one).

➤ [AudioMapper User Guide](#)

## Art-Net and DMX Config

Delta has the ability to send out an Art-Net stream from the timeline and listen to Art-Net in order to activate any command from the external control command set. Art-Net can be converted to DMX using inexpensive Ethernet (RJ45 – Art-Net) to DMX (5 pin DIN) devices.

The configuration page sets up the output parameters for Art-Net and whether this is enabled for input and output separately:

## Output

### Output Art-Net Data Enable

Select this to enable the continuous Art-Net data stream output

### Art-Net NIC

Choose which network adapter to broadcast Art-Net data from

### Broadcast Address

Choose 255.255.255.255 for the whole network or a more limited address as required.

### Art-Net Universe

Value 0 – 15, these behave as separate sets of data on the network

### Art-Net SubNet

Value 0 – 15, these behave as separate sets of data on the network

### Max Channels (Output)

Art-Net has 512 maximum channels, but you can select to output only a subset of this if required. Note that some DMX devices do not work properly unless they receive all 512 channels.

### Broadcast Port

Select which port on which you wish to send Art-Net data. Default is 6454.

## Input

### Input Art-Net Data Enabled

Select this to enable Art-Net listeners (see Art-Net resource section).

### Art-Net NIC

Specify the NIC to receive the Art-Net data.\*

### Receive Port

Select which port on which you wish to receive Art-Net data. Default is 6455.

### Enable TestMode

Selecting this increments all output channels continuously in a ramp for testing.

**Note** that only one server should be set to broadcast out to a specific Universe / SubNet, as multiple servers broadcasting on the same settings will conflict.

\* You cannot send Art-Net back into the same server that DeltaServer is running on if you have input and output NICs set to the same interface. DeltaServer will assume **exclusive control** over

the input Art-Net port for the NIC chosen. The input signal will therefore not reach any other application on the same machine listening to the same port on the same NIC.

## User Information / Stats

By pressing 'i' on the playback window, or using the 'i' button on the DeltaGUI toolbar, you can toggle User Stats on or off which provides real-time information on the playback window, which can be selected in this config page.

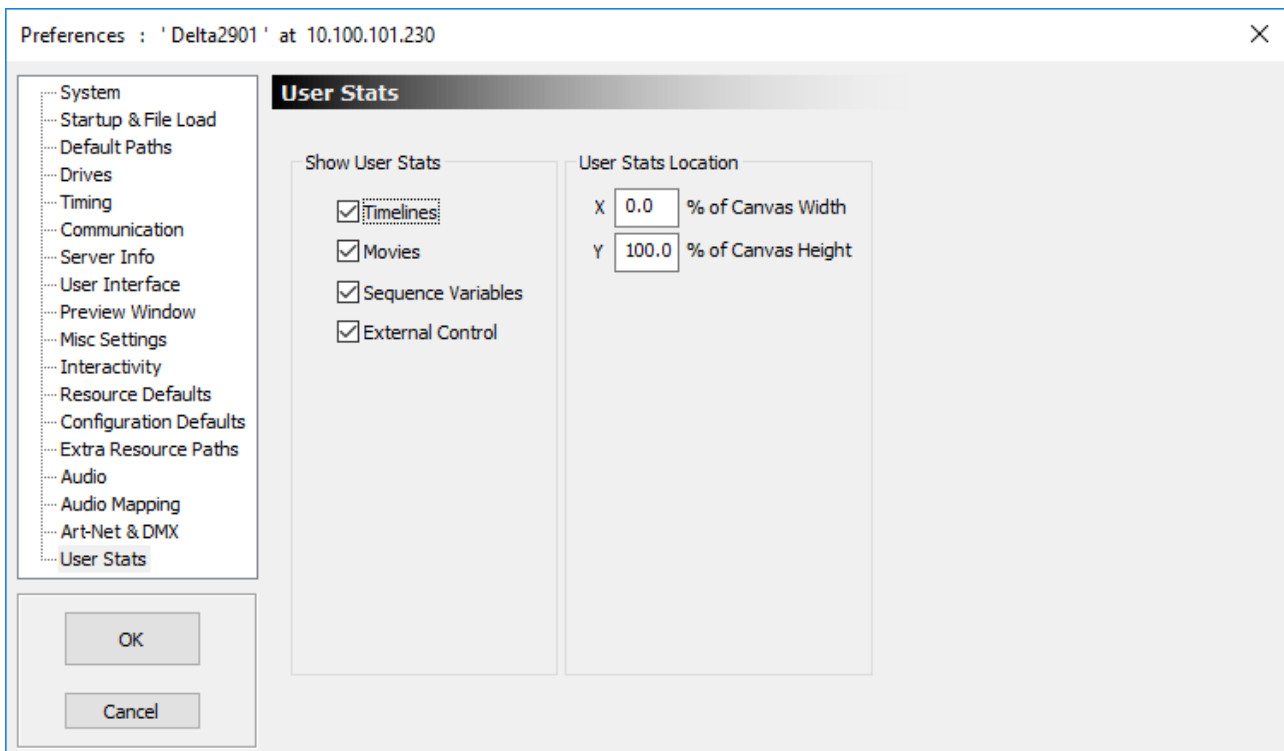

### Timelines

All active timelines are shown with the timecode, whether t

he timeline is playing or cued

### Movies

All in-scope and enabled movies are shown with the time from the start of the movie, time remaining in the movie, percentage complete, timeline and name.

### Last External Control Message

The last message and when it was sent are shown here.

### Sequence Variables

All sequence variables which have Watch enabled are shown with their values – configure Watched status in the *View > Sequence Editor > Global Variables* page.

### Example playback window shown:

```
Timelines ( 30.00 fps)
1: 00 : 00 : 01 : : 15 (Cued)
R: 00 : 00 : 00 : : 00
From Start      Remaining      %      TL      Name
00:00:00:15    00:00:00:15    50%    1      Heart1
00:00:01:15    00:01:20:00    1.8%   1      Amazon 720
Last External Control Message
13:19:18 : status
Sequence Variables
$count : 11
$x : 226.000000
$ddd : jan
```

For interpretation of graphs and stats, see:

➤ [Playback Window](#) <sup>33</sup>

## Display Configuration Features

---

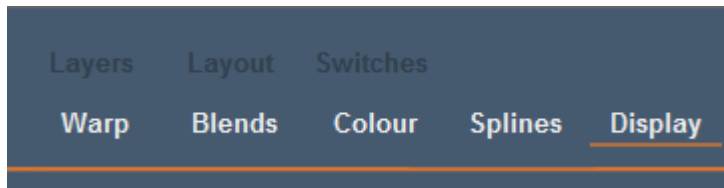

### Definitions for Visual Media

Dimensions are described in pixels (flat plane screens) or degrees (spherical or ellipsoid domes).

#### Canvas

The total surface that displays the projected show. This may be a matrix of LED screens, a projected flat screen, a spherical surface (dome), or a complex 3D surface for which media is specifically mapped to a mesh.

#### Channel

One, or many, projection devices each of which throws all or part of a show onto the canvas.

#### Show

A compilation of one of many media resources, including applied warps, blends, effects, transitions and display control sequences, arranged on one or more timelines.

#### Media resource

A projected media item, which can be dedicated to, or divided between channels. It can be positioned, resized or reportioned, forced to fill a channel, or occupy a small portion of a channel. It may be designed for the canvas, channel mapped, or be a live capture, for example. Compiled on layers in a show timeline, they have individual properties.

### Display Modes

Delta display modes are licensed options. There are three display modes available, for different kinds of canvas or display surface. In each, the surface is divided into projection channels, according to screen size and media requirements.

#### Flat or curved plane



This mode defines only width and height for a single rectangular canvas, and applies warping and blending to fit each channel perfectly together. See: [Display Configuration: Flat Plane Mode](#)<sup>(161)</sup>.

## Dome or frustum



Advanced geometry automatically takes care of spherical or ellipsoid surfaces in this mode, distributing media between channels, applying blending, and using autoalignment options. See: [Display Configuration: Dome Mode](#) <sup>(193)</sup>.

## Mesh



Mesh mode (projection mapping) is for projection onto irregular objects or surfaces, requiring a 3D model or 'mesh' to provide calibration points for the media. For viewing from a single, or specific eye-points, flatplane media is mapped onto the model. See: [Display Configuration: Mesh Mode](#) <sup>(221)</sup>.

## Configuration features

### [Warp](#) <sup>(142)</sup>

Changing the shape of individual channels to match the screen surface

### [Blends](#) <sup>(150)</sup>

Blending overlapping areas between channels for seamless projection.

### [Colour](#) <sup>(153)</sup>

Adjusting colour between adjacent channels.

### [Splines](#) <sup>(155)</sup>

Geometric paths along which visual media move, to a set timing pattern, when in scope.

## Display

Setting up channels for different projection modes: flatscreen, composition, dome, or mesh.

## Output Setup

---



Output setup allows configuration of channel locations in the playback window, overall gamma, and which physical outputs are active. **Note that the setup here should match that set in any graphics card setup on the server.**



Press the Output Setup button to show the output mode dialog:

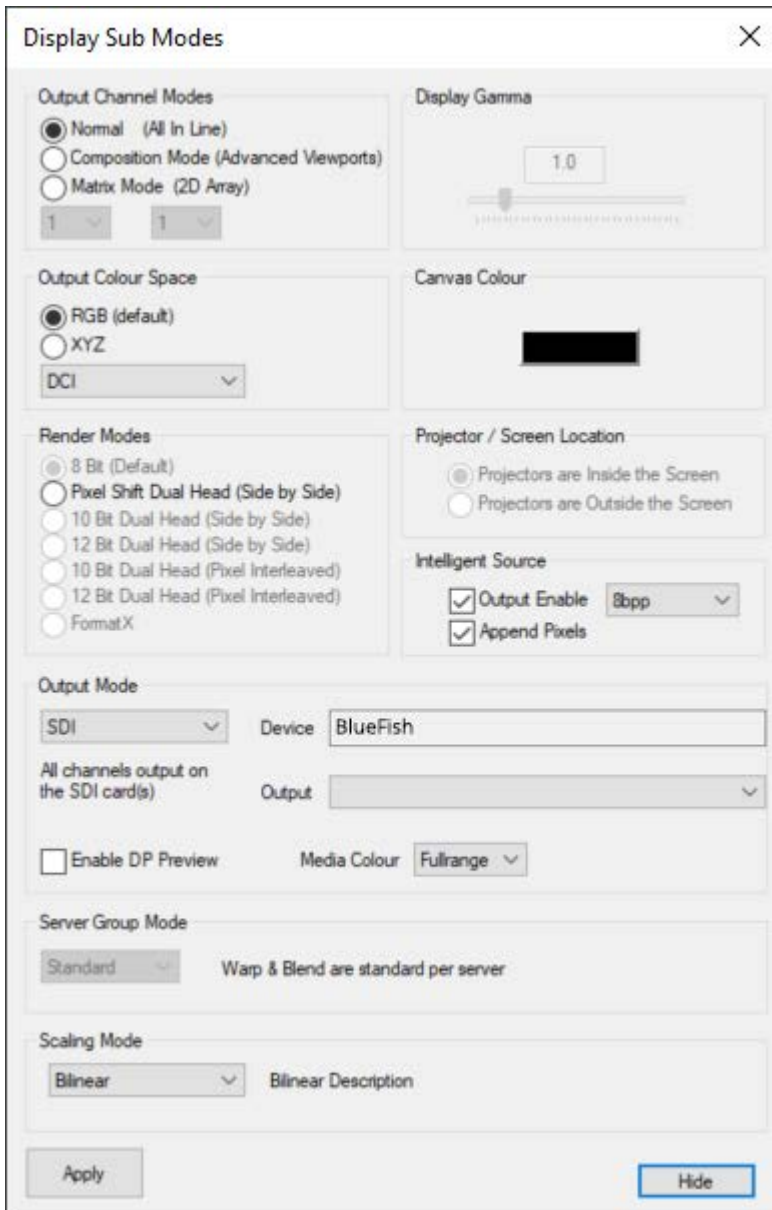

## Output Channel Modes

If **Normal**, channels are arranged in a horizontal line on the desktop.

If **Composition Mode**, output channels are directly editable in XYWH on the output framebuffer.

If **Matrix Mode**, channels can be arranged in a X by Y grid on the playback window.

## Output Colour Space

RGB is the normal colour space, but some projectors, typically in Digital Cinema, take an XYZ colour space. The dropdown list contains various RGB-XYZ mappings:

- DCI and CIE are fixed, internal mappings.
- Same is a 1:1 RGB-XYZ (no change) mapping for testing.
- DCI\_File is stored in System / ColourSpaceConvert.xml file and can be changed.

## Render Modes

This choice relates to the way colour data is packed and how particular projectors interpret that data. It does not enable bit-depth colour and does not apply to SDI output mode. In most cases this should be left at 8-bit.

High bit-depth colour is an optional licence. For working with 10-bit colour depth, please see this section in our [Display Configuration guide](#).

Current high bit depth capabilities for Delta are:

Connector type	High bit depth
SDI	Up to 12 bit
HDMI 1.4	Up to 10 bit
HDMI 2.0	Up to 12 bit
DisplayPort	Up to 12 bit
DVI	(Older servers) 8 bit only from single cable. Special packing formats for Dual cable or Dual DVI (including JVC 12 bit and others) are also available. [Please contact us for more information.]
Rivermax™ SMPTE 2110 (ST 2110)	Any

**Note:** Wobulation techniques for JVC are also natively supported.

## Norxe Wobulator Projectors

When using a Norxe Wobulation projector, the user may want to duplicate the output from Delta, but shift this duplicate by 0.5 pixels in height and width.

With Delta 2.7 build 6, a Pixel shift render mode was added in *Display > Output Setup*.

This shift of half a pixel can also have an interleave value set meaning that the first output from Delta is providing all the 'even' vertical pixels and the second (duplicate) is providing all the 'odd' pixels. These feeds both go into the projector and are overlaid on top of each other to create the image. You can then enable wobulation on the projector, which takes advantage of the half-pixel shift in the x/y

axis. The pixel shift values can also be minus values if the wobulation is in a negative axis. This will require adjustment to some registry settings.

Default Pixel shift properties in the Windows registry can be found in  
 \HKEY\_LOCAL\_MACHINE\SOFTWARE\7thSense\Delta\Graphics:

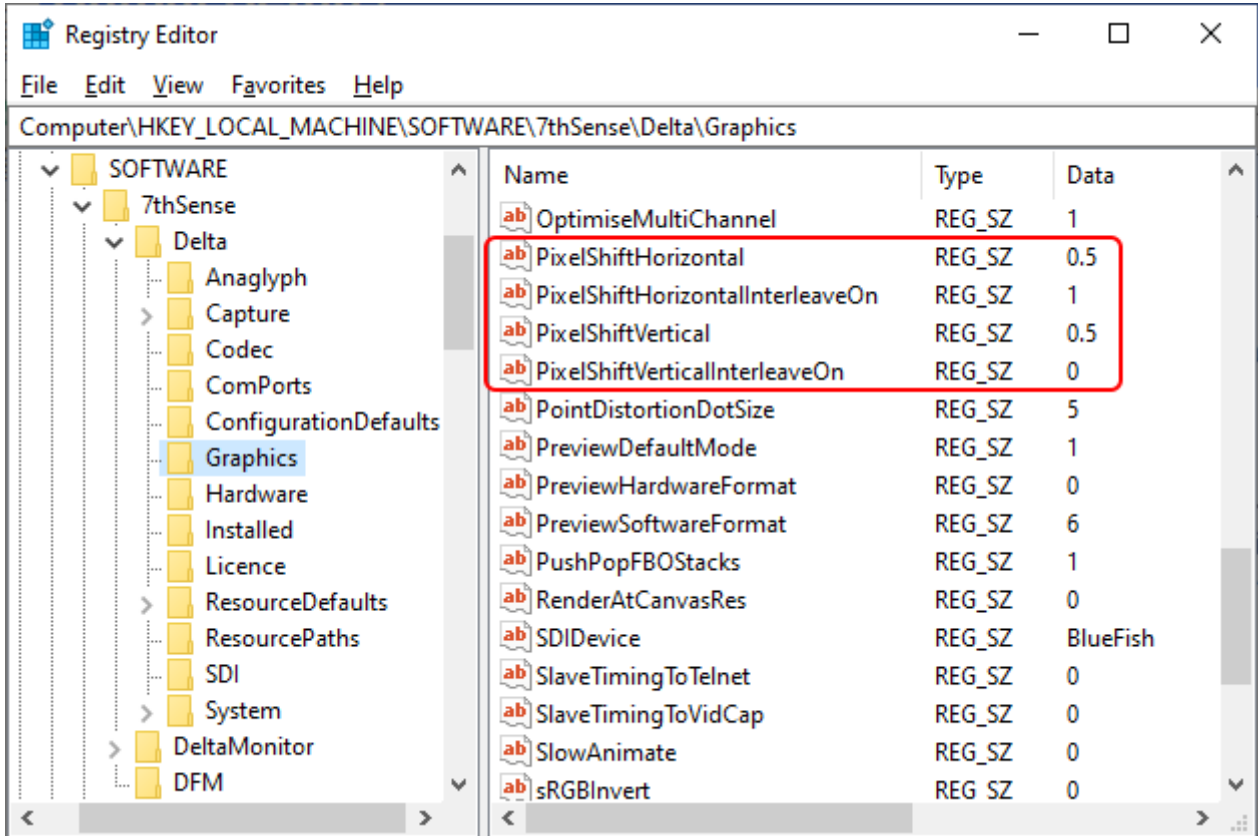

Key	Default	Function
PixelShiftHorizontal	0.5	If pixel shift is being used, sets the shifting amount of pixels horizontally
PixelShiftHorizontalInterleaveOn	1	If pixel shift is being used, sets the flag to interleave pixels horizontally
PixelShiftVertical	0.5	If pixel shift is being used, sets the shifting amount of pixels vertically
PixelShiftVerticalInterleaveOn	0	If pixel shift is being used, sets the flag to interleave pixels vertically

## Registry Edits

7thSense software uses the Windows Registry extensively, and on occasion we make recommendations for changes.

- Before making any changes, close DeltaGUI and DeltaServer.
- DeltaServer can take up to 10 seconds to fully close in the background, even if it appears that all the Windows have closed. Ensure that Delta has *fully* closed before opening and/or refreshing, and finally editing. The best way to ensure this, is to watch Windows Task Manager > Details list. You will see 'DeltaServer.exe' in this list if DeltaServer is still running. If it won't close for any reason, you can right click on it in the list and choose 'End Process Tree'.
- Make a note of any setting before you change it, in case you want to change it back.
- Only make the changes as recommended and only to those registry keys.

## Projector / Screen Location (Dome Mode required)

For Dome (Frustum) and Mesh Modes, the standard configuration is to have projectors inside a dome screen.

For those systems where the projectors are projecting onto the outside of the dome screen, choose the 'Projectors are Outside the Screen' option. You must then place the channels (virtual projectors) outside and pointing at the screen. Intelligent resources in this mode will also automatically horizontally mirror visual resources so that text still reads correctly.

## IntelligentSource™

Check 'Output Enable' if you are require IntelligentSource frame data in your output. Select the format for the IntelligentSource data row to match that of the receiving decoder. By default Delta will sacrifice pixels of the first row of each frame. Alternatively you can choose to append a row at the top of each frame to contain the IS data and employ an EDID adjusted for this.

- See also [IntelligentSource™](#) <sup>(326)</sup>
- [Composition Mode and IntelligentSource](#) <sup>(191)</sup>

## Display Gamma

This slider controls the overall display gamma on the server PC – this value is saved in the file.

## Canvas Colour

This is the background colour which shows when there are no visual resources on the timeline.

## Output Mode (Optional Licences)

Select from DisplayPort (default), SDI, VR or ST2110 modes to match the server configuration

- DisplayPort mode outputs on the server's graphics card.
- SDI mode outputs on SDI output cards (BlueFish, Matrox, if present).
- VR Headset (unavailable in Flatplane Mode) outputs on HDMI to the VR headset, with optional DisplayPort preview (extra load) of the VR view. This requires mesh mode and stereo licences.
- ST 2110 enabled by licence for servers with Mellanox Rivermax™ network adapters.

Note: The optional DisplayPort preview adds extra load to the canvas for modes other than DisplayPort.

➤ See [Appendix C](#)<sup>447</sup> for more SDI details.

## Server Group Mode (Optional Licence)

This mode is for when multiple servers drive a single 4K projector (if required) and allows the user to designate which half or quadrant this server is responsible for – when adjusting warp and blending, the same information is used in all servers to maintain coherent geometry across all servers. Since a single Delta server can drive multiple 4K projectors, this option is for high-end testing only.

## Scaling Mode

From Delta 2.7 build 6, this additional control allows for choice of scaling mode, bilinear, Lanczos or bicubic. Scaling mode is accessible via external control.

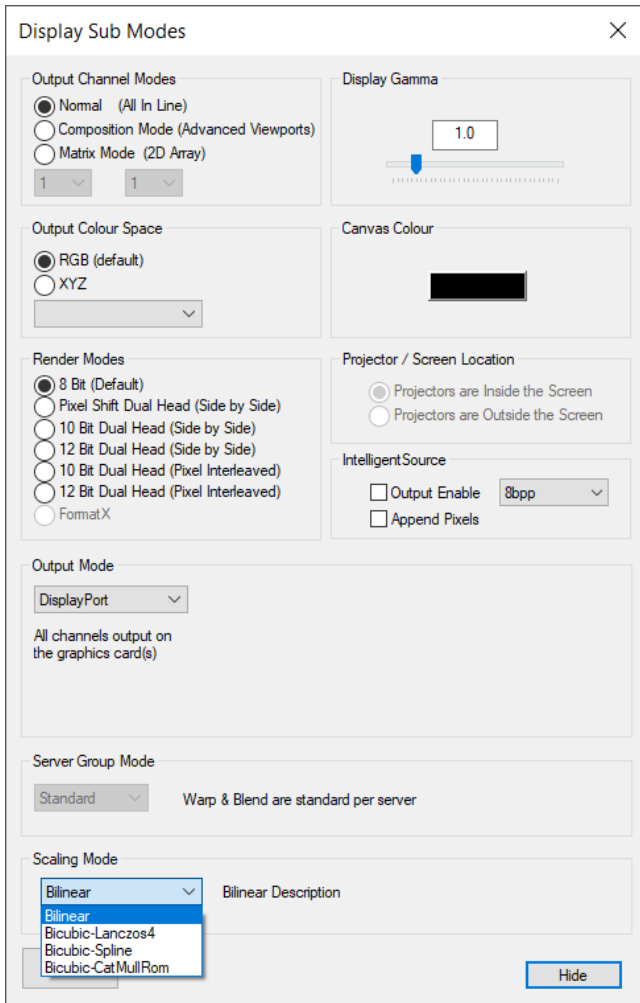

## Test Patterns



In addition to the Pixel Grid (main toolbar button) or warping grids, test patterns are available to make alignment and adjustment easier when configuring any display mode.

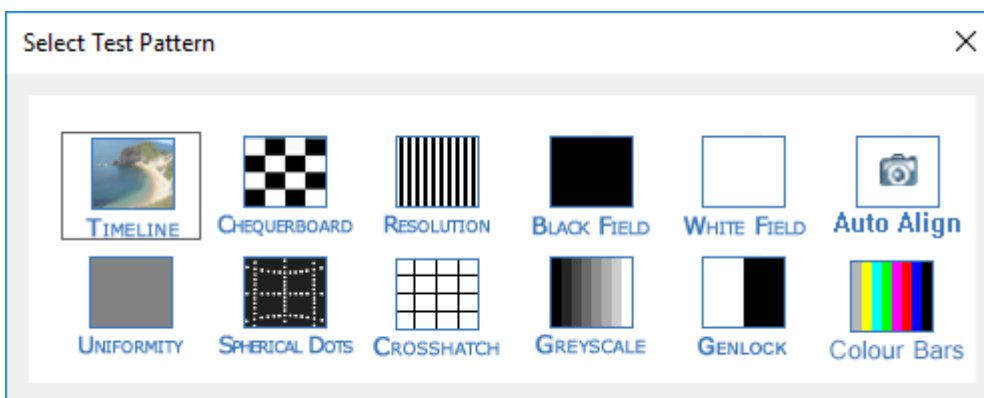

Test Pattern	Type	Description
Timeline	Resource display	Shows the resource(s) that are applied to the timeline at the set time
Chequerboard	3D test pattern	A set of 15 degree black and white boxes in a sphere
Resolution	2D test pattern	This is a vertical or horizontal grill of one pixel off / one pixel on which fills the screen
Black Field	Full black output	
White Field	Peak white output	
Auto Align	—	—
Uniformity	50% drive level field	
Spherical Dots	3D test pattern	A spherical grid of dots, in which the size of the box and dot size is configurable
Crosshatch	3D test pattern	A spherical grid of lines, in which the size of the box and dot size is configurable
Greyscale	3D test pattern	A spherical set of grey bars. You can choose the orientation from 4 settings
Genlock	Black / White pattern	When playing, alternately flashes white / black to allow genlock checking across channels  <b>Photo-epilepsy Warning</b>  This test pattern displays rapidly flashing black and white screens (frequency: 10% of the frame rate), and may cause seizures in the very small minority of people who are susceptible to photo-epilepsy. Do not display in an auditorium without issuing this warning.
Colour Bars	2D test pattern	SMPTE standard colours

## 3D: Passive Stereo Mode

As an option, Delta can enable Stereo mode, which can be Passive or Active.

In Passive mode, Delta's layers are treated as stereo depth which, when viewed on a passive or active stereo display system, create the illusion of distance which can bring another dimension to presentations.

Layer 1 is treated as the nearest layer; the Background layer is farthest away. All layers between 1 and background are scaled in distance according to the layer number. Using this system, you can have layered objects float in front or behind other media according to the show requirements.

## Configuration

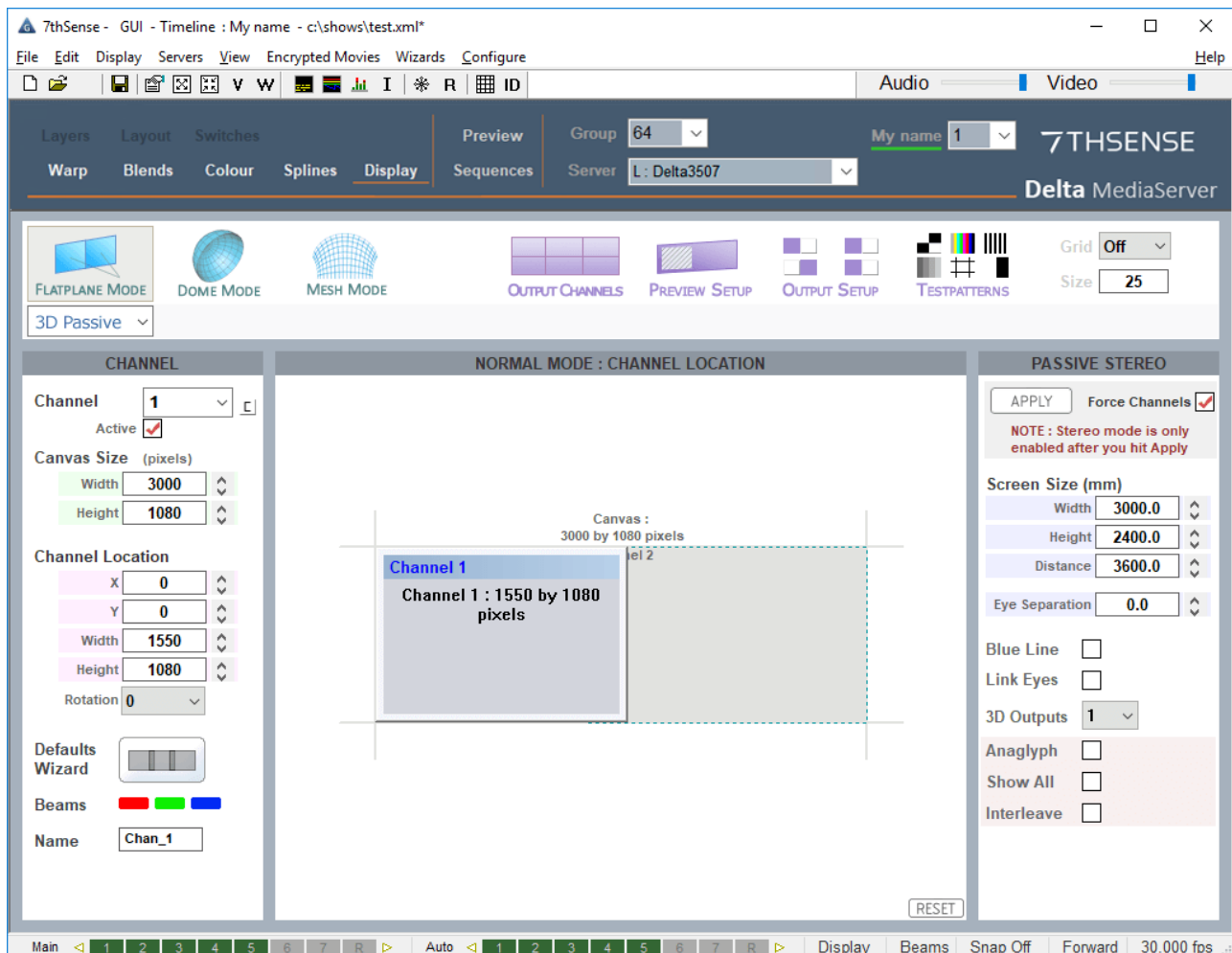

In passive stereo, the canvas is divided into pairs of channels, one each for left and right eyes. The number of channels will therefore be forced into an even number. The number of pairs is set using the **3D Outputs** dropdown ( $2 \times 3D$  outputs = 4 channels active). Each channel is output through a separate video output to a projector, exactly overlaid on the screen, each projector having a different polarisation. Using inexpensive passive stereo glasses, each eye receives only the polarised image for the relevant eye, and in this way, each eye sees a slightly different view, creating the stereo depth.

## Requirements

- Pairs of projectors overlaid, each one polarised with a non-depolarising screen
- Pairs of channels output from Delta
- Inexpensive polarised or Infitec glasses



**Blue Line mode**

places a quarter-channel width blue line on the last line of video for the left eye and three-quarters-width line for the right channel. Some projectors support this mode instead of a separate sync signal from the PC.

**Link Eyes**

links the geometry, colour and blending from channel 1 onto channel 2, channel 3 to 4 and so on. In this way, if the two projected images are already aligned, only add warp and blend to odd numbered channels and adjust as normal – even numbered channel warp will be identical to its odd numbered partner.

**Anaglyph mode**

creates a realtime anaglyph (red/blue stereo) from non-anaglyph content. Suitable red/blue glasses are required.

**Show All**

for anaglyph shows the composite Red/Blue channel in addition to the 2 channels which create this mode. This is useful to have anaglyph and passive stereo of the same source.

**Interleave mode**

interleaves the left and right eye images in a 1 pixel chequerboard pattern, suitable for certain 3D LED walls.

You must press [Apply] for passive stereo to be enabled.

**Force Channels**

if this is checked, pairs of channels are made active and the second channel is copied over the first so they are overlapped. If the checkbox is not checked, your existing channels are left untouched, so you can configure passive stereo as required.

**Stereo Wizard**

- The Wizard can help you create simple passive 3D shows. See: [3D Stereo Show Wizard](#) <sup>140</sup>

## 3D: Active Stereo Mode

---

In this mode, pairs of Delta channels are interleaved in time, and a single output is sent to a single projector. Since we want to maintain sufficient update rate for each eye, this single output from Delta has to run twice as fast as the passive stereo solution, as does the projector. Shutter glasses, synced to the stereo output of Delta, are synchronised to only show each eye the relevant image, creating the stereo depth.

The Eye Separation (IOD) is set here to use Delta's layers as additional planar shift to create artificial depth. This defaults to 0, which means not using layers to create depth, relying on the depth within the content.

## Configuration

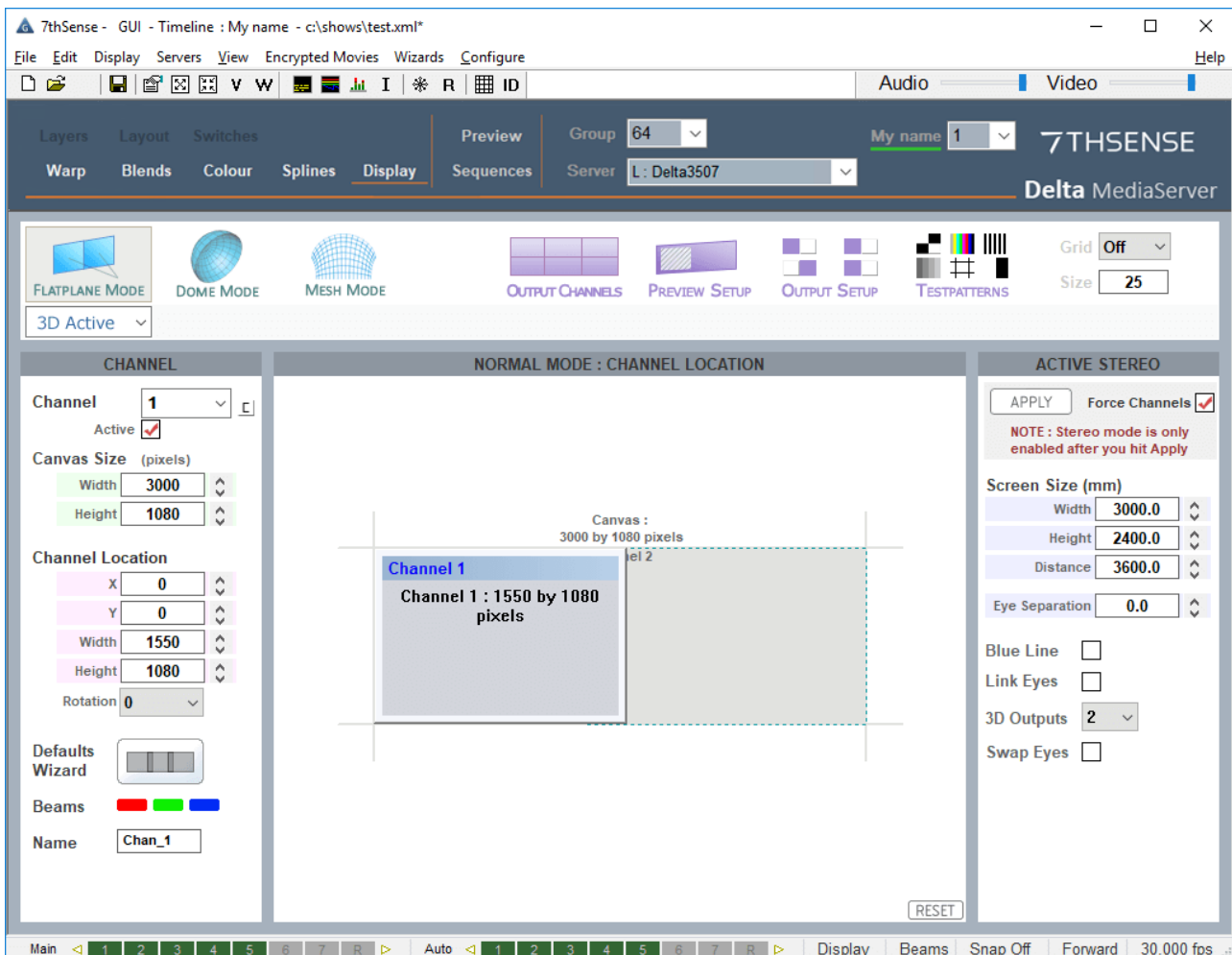

Choose 1 to 8 × 3D Outputs and press apply – pairs of channels are made active, and the second channel is copied over the first so they are superimposed. If the checkbox is not checked, your existing channels are left untouched, so you can configure passive stereo as required. Note that odd channels (1,3,5,7) are always left eye and even channels (2,4,6,8) are always right eye. You can configure content to be on left or right eye by editing the resource and change the Eye parameter.

### Blue Line mode

places a quarter-channel width blue line on the last line of video for the left eye and three-quarters-width line for the right channel. Some active stereo projectors support this mode in addition to the traditional stereo sync input.

### Link Eyes

links the geometry, colour and blending from channel 1 onto channel 2, channel 3 onto channel

4 and so on. In this way, both channels fed to a single active stereo projector are adjusted at the same time if the control is placed on an odd-numbered channel.

**Note:** You must press [Apply] in order for stereo to be enabled.

### Force Channels

if this is checked, pairs of channels are made active and the second channel is copied over the first so they are overlapped. If the checkbox is not checked, your existing channels are left untouched, so you can configure passive stereo as required.

To use Delta's layers as additional depth, for both Passive and Active Stereo, simply enter the screen and Eye-point locations and size, and choose the Eye Separation to match your system – these values affect only the additional stereo separation activated per layer (layer 1 has most separation, background layer has 0 separation).

A typical Eye Separation is 65 mm, though this value can be experimented with to achieve the right amount of stereo. *Beware of using too much separation, as this can make objects appear behind the observer's head, causing discomfort.*

The Canvas and Screen location can be entered so that one PC can play the left half of a stereo screen, another the right half – enter appropriate Channel values to cover the left and right half of the canvas in this case.

## Typical Requirements

- One projector per output, fast enough for the higher video rate
- One channel output per projector from Delta using stereo-capable graphics card (requires optional stereo licence)
- Shutter glasses or Z Screen

## Pre-Rendered Anaglyph Stereo Content

If an anaglyph movie has been rendered into left eye / right eye already, the Eye separation should be set to 0.

Alternatively, place this on the background layer, which has no additional eye-offset applied by Delta.

## Left Eye or Right Eye Separate Movies

After placing left and right eye movies on the timeline, you can edit each resource to move it to the left eye or right only (pre-rendered for that eye).

## Left/Right or Top/Bottom Configuration

Some movies come with both eyes as left/right side by side, or top/bottom, this can be selected in the resource dialog.

## Stereo Wizard

- The Wizard can help you create simple active 3D shows. See: [3D Stereo Show Wizard](#)<sup>(140)</sup>

## 3D Stereo Show Wizard

Choose DeltaGUI menu *Wizards > Create Stereo Show*.

On the first page, select the Left and Right eye movies:

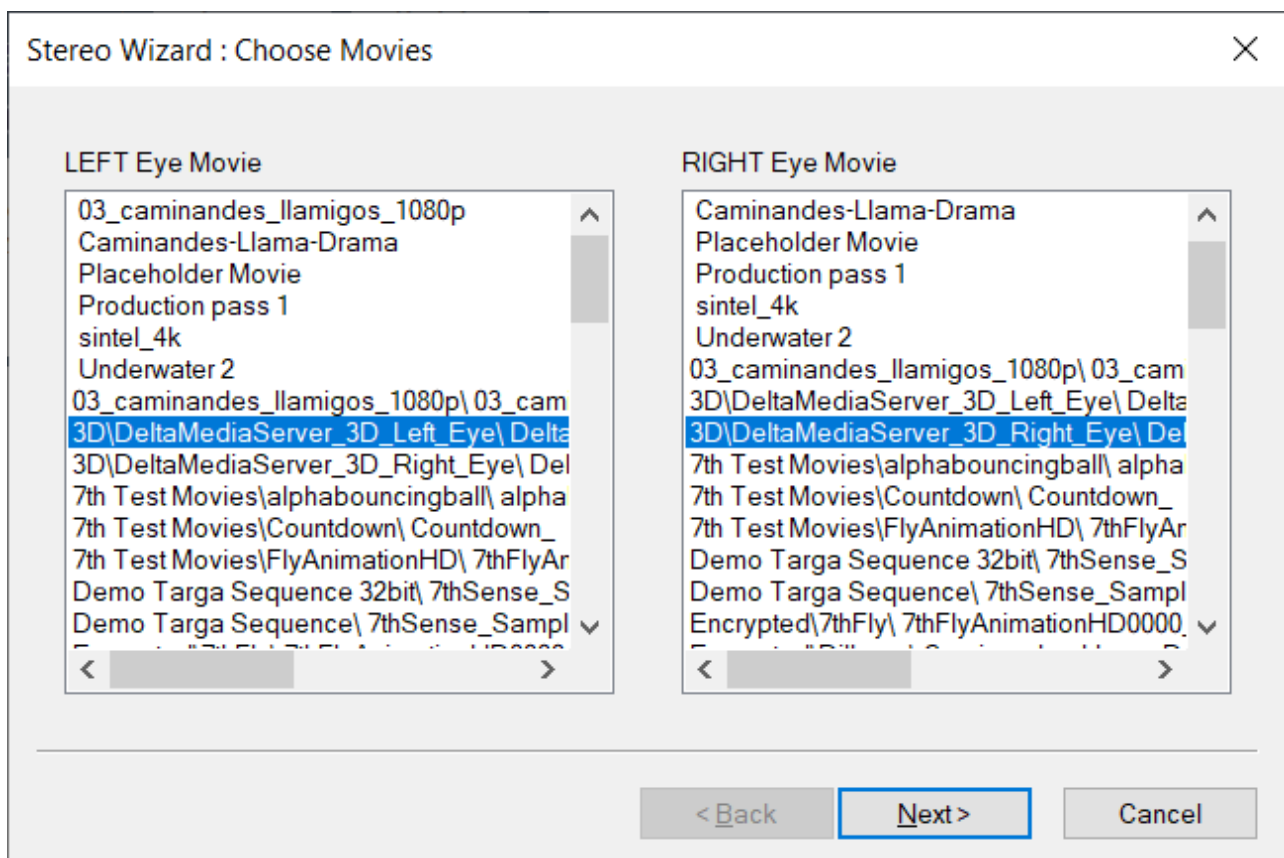

On the second page, choose which audio files to include and the FPS of the audio files:

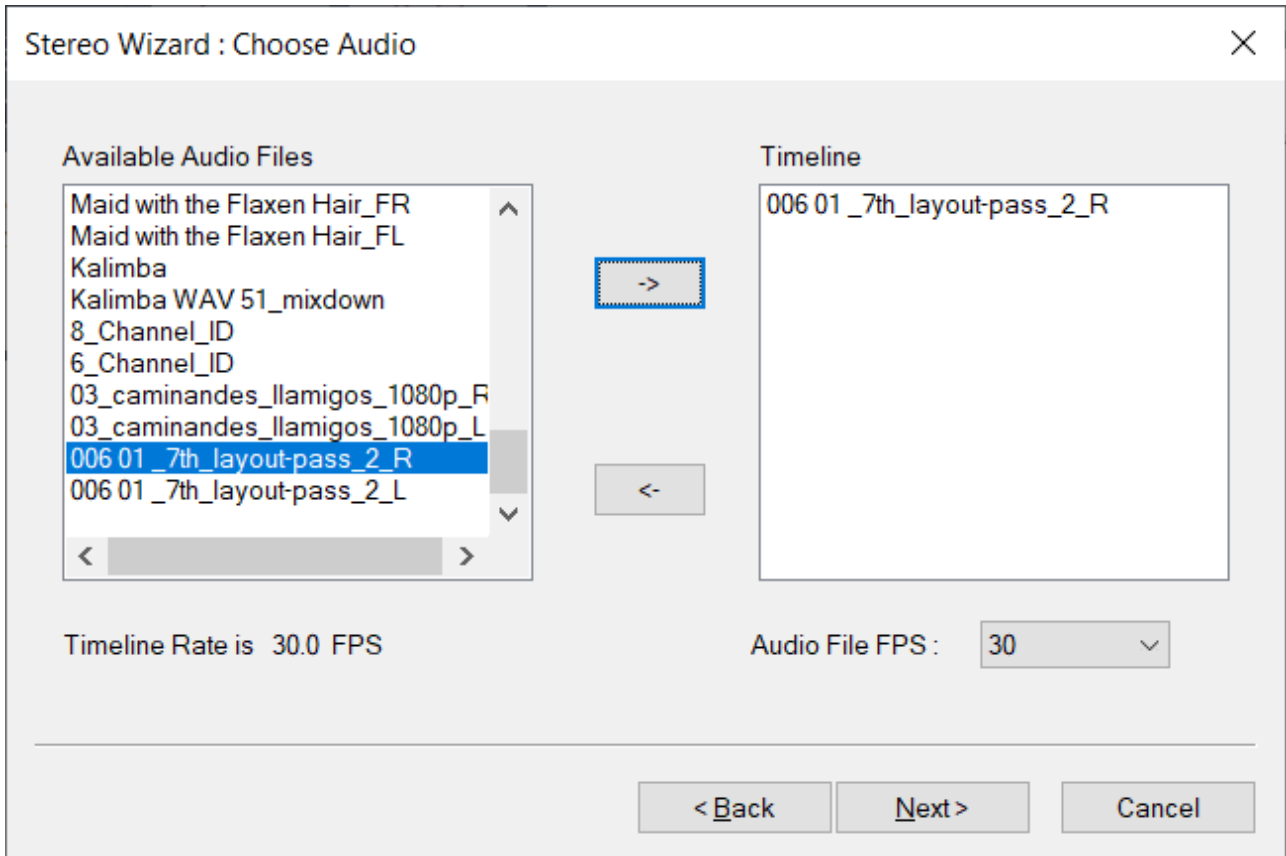

When adding, select speaker destinations for each track:

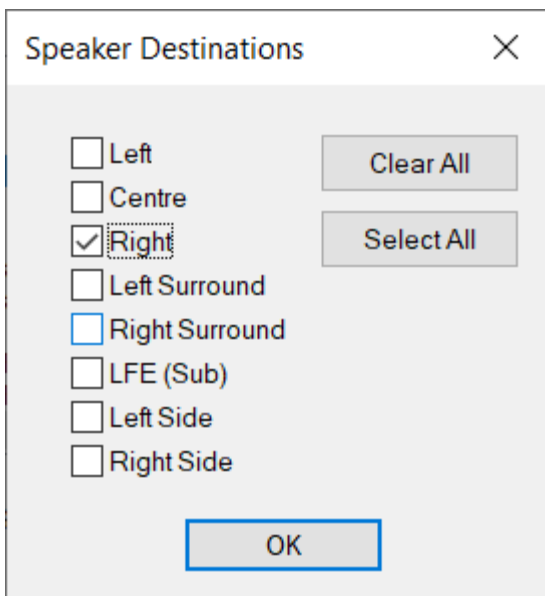

On the last page, choose mode – Active or Passive – whether to add a loop, and if there is any time offset between audio files and movies:

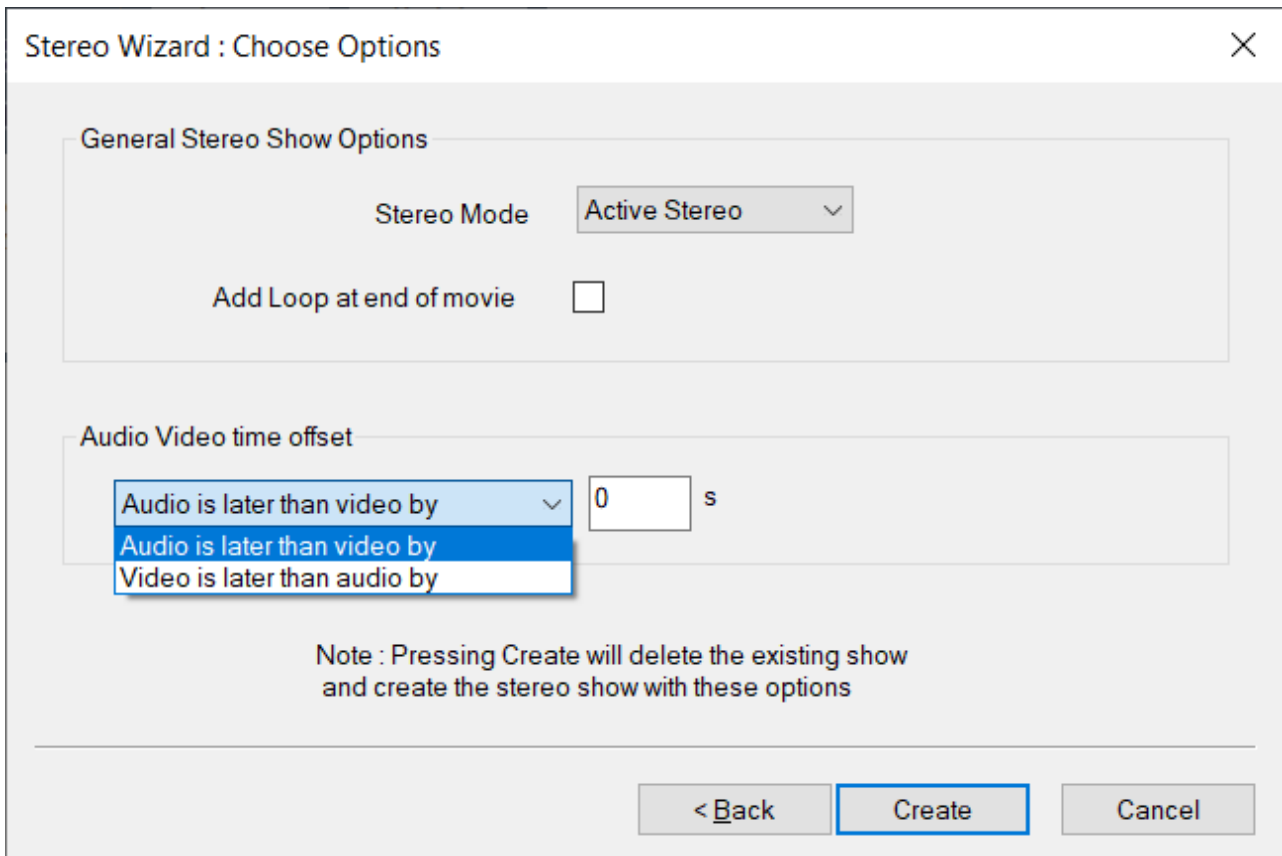

Click [Create], and the timeline is populated, ready to play.

## Display Configuration: Warp

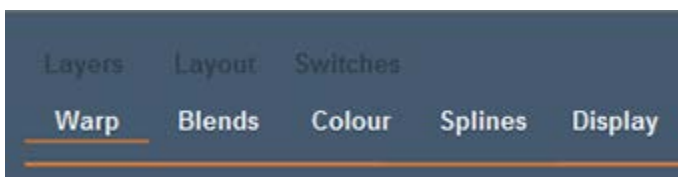

Geometry on the background is typically used to align the Delta image onto the display system, perhaps to correct slight errors in the display, or to make the image geometry correct for a curved screen display system. Geometry / warp resources on non-background layers affect resources on that layer across the whole canvas, not per channel.

Background geometry can also have 'Fixed' enabled (in Properties) – this will auto-reset the start frame of this geometry to frame 0. If Fixed is disabled, you can set the start frame as normal.

There are four warp modes available:

- [Timeline](#) <sup>143</sup>
- [Colour Convergence](#) <sup>144</sup>

➤ [Surface Warp](#) <sup>144</sup>

➤ [Point Distortion Warp](#) <sup>146</sup>

## Timeline



Timeline warp uses common projector terms such as H-Size, Left-Keystone or Top-Right Bow. This method is most precise and usually follows the technique of start in the centre with whole size picture controls, working out to the corners using half-size picture controls,

then corner controls. In this way, the alignment is achieved with the minimum of interaction between areas. Note you can drag the slider, or click the arrow buttons either side for fine control.

To use this method, you need to place a warp resource on the background layer for each active channel you want to warp. (In FlatPlane mode, the Defaults Wizard will create these for you.)

You can also save this resource to the resource pool for use in other shows, using the 'Copy to Resource Pool' button in the resource pool area.



Global controls treat the whole canvas



Half-controls warp only half of the canvas, from a mid-line



Cubic bows treat corners by warping one quarter of the canvas



Quadratic corners warp one quarter of the canvas with a slightly more acute reach into the corner. The alternative when making finer adjustments is point distortion.

Each warp is described above the slider control that controls its extent. Numeric values can also be typed in:

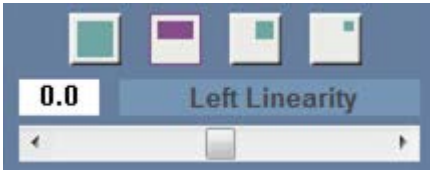

## Colour Convergence

Some projectors require red and blue to be warped onto the green image, by setting the background warp resource to Converge Red or Converge Blue, you can have this warp resource alter red or blue only. Placing a second warp on this channel in normal Warp Mode allows all 3 colours to be warped at the same time while preserving the red and blue offsets.

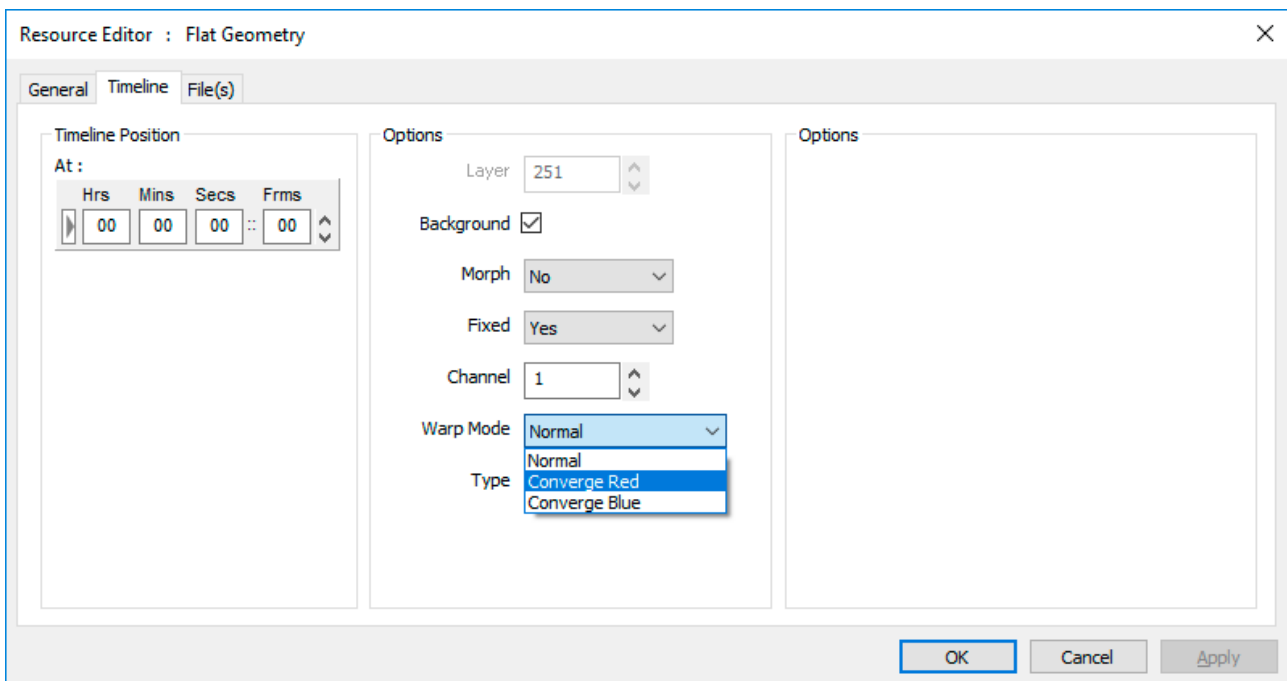

## Surface Warp



Surface warp is an additional geometric distortion which is built into a geometry resource.

- Both surface and point distortion modes can be used at the same time.
- A surface-warped geometric resource can be placed on any layer, and affects the media in that layer.
- On the background layer, surface warp becomes Channel-based. (Point Distortion is still available on each channel and can be used together with any resource-based mode.)



Surface mode is useful for quickly pulling the shape around with a mouse – you can choose the number of nodes, from only 4 in total, up to a  $13 \times 13$  grid of points by pressing the H+, H-, V+ and V- buttons followed by the Apply button (or Enter). Note that the new grid density will follow approximately the shape of the original node count.

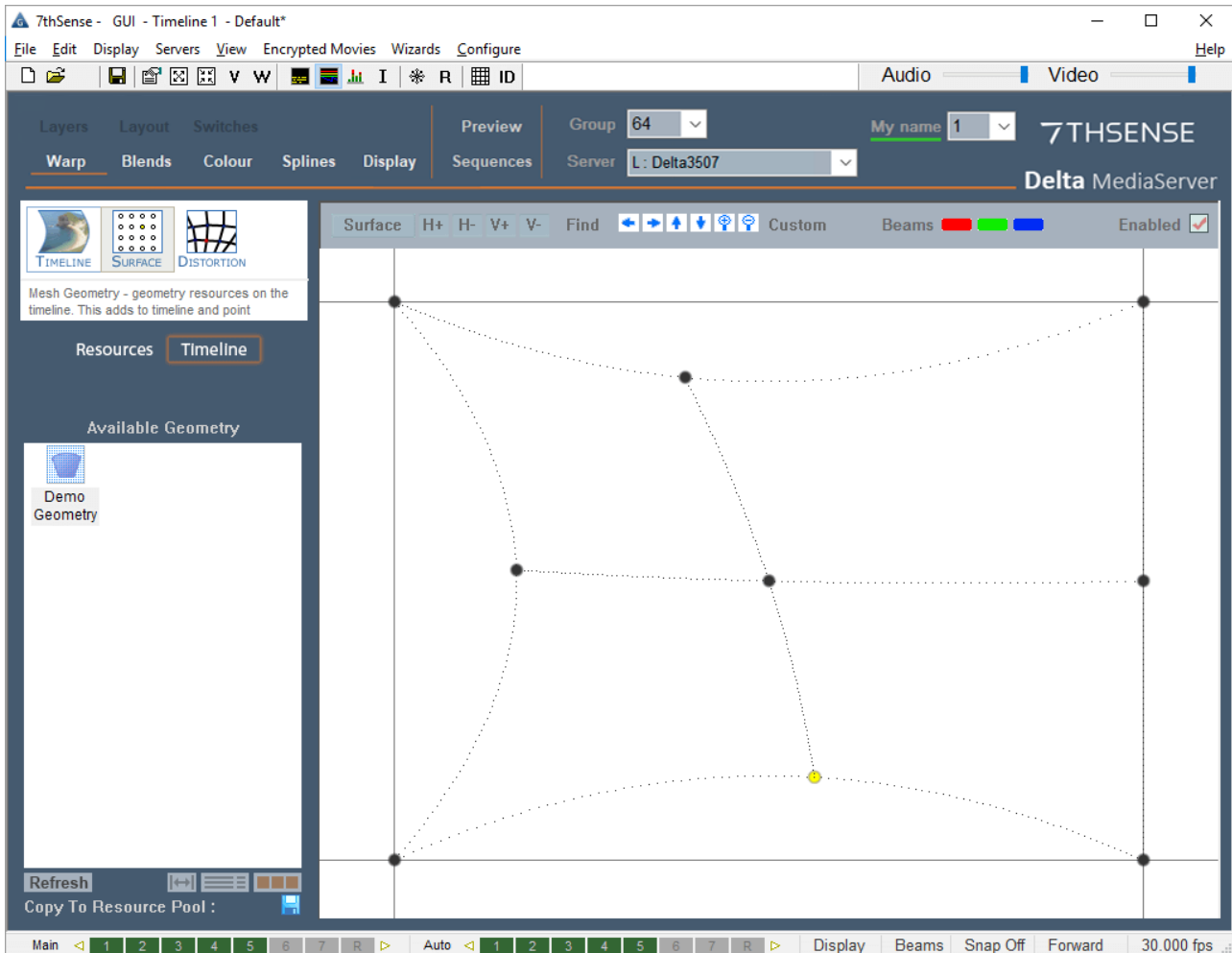

## Warp Controls

Zoom in/out of grid

blue buttons, or  
Ctrl+mouse wheel

Reposition the grid in DeltaGUI

blue arrow buttons, or  
left mouse button to drag, or  
Shift+arrow keys

Select a node or nodes

arrow keys (first to be selected is bottom left), or  
left mouse click;  
add additional nodes with Ctrl+left mouse button

Move a node or nodes	Ctrl+arrow keys (fine control), or Ctrl+left mouse button to drag
Add or Remove a grid line (row or column)	H+, H-, V+, V- buttons
Add a custom grid line (row or column)	'Custom' button menu > Add Custom Line / Column
Move a grid line (row or column)	'Custom' button menu > Edit :Line / Column Reference
Remove a grid line (row or column)	'Custom' button menu > Remove Custom Line / Column

Under the Surface button, you can reset a selected point or points, or the whole grid, and also change from Linear Interpolation (straight lines between nodes), or Spline Interpolation (smooth curves). You can also change the dot size onscreen and reset points or the grid.

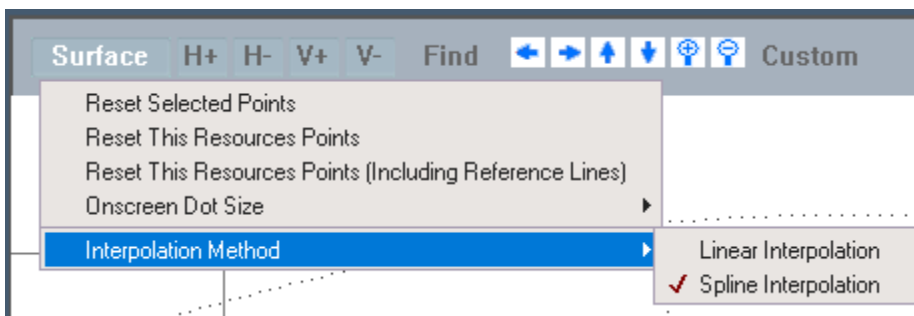

To find the active dot's location, even if off screen, press the **Find** button – this highlights the X and Y lines leading to the selected node on the actual canvas. This will disappear automatically after 10s.

### Point Distortion Warp

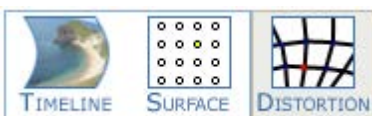

Point distortion is an additional channel-based geometric distortion which is typically used in curved screen displays to finely tune geometry.

- Add a flat geometry resource to the timeline, and set its properties to background layer and to the required distortion channel.
- Each channel has an independent distortion map and these are stored in the XML file.

On the Warp page, select Distortion from the Timeline / Distortion tab control. DeltaGUI now shows a 21 × 21 or 11 × 11 grid of points (configurable in the **Grid** menu), and the display shows a grid of dots. Both dot size and grid density can be adjusted.

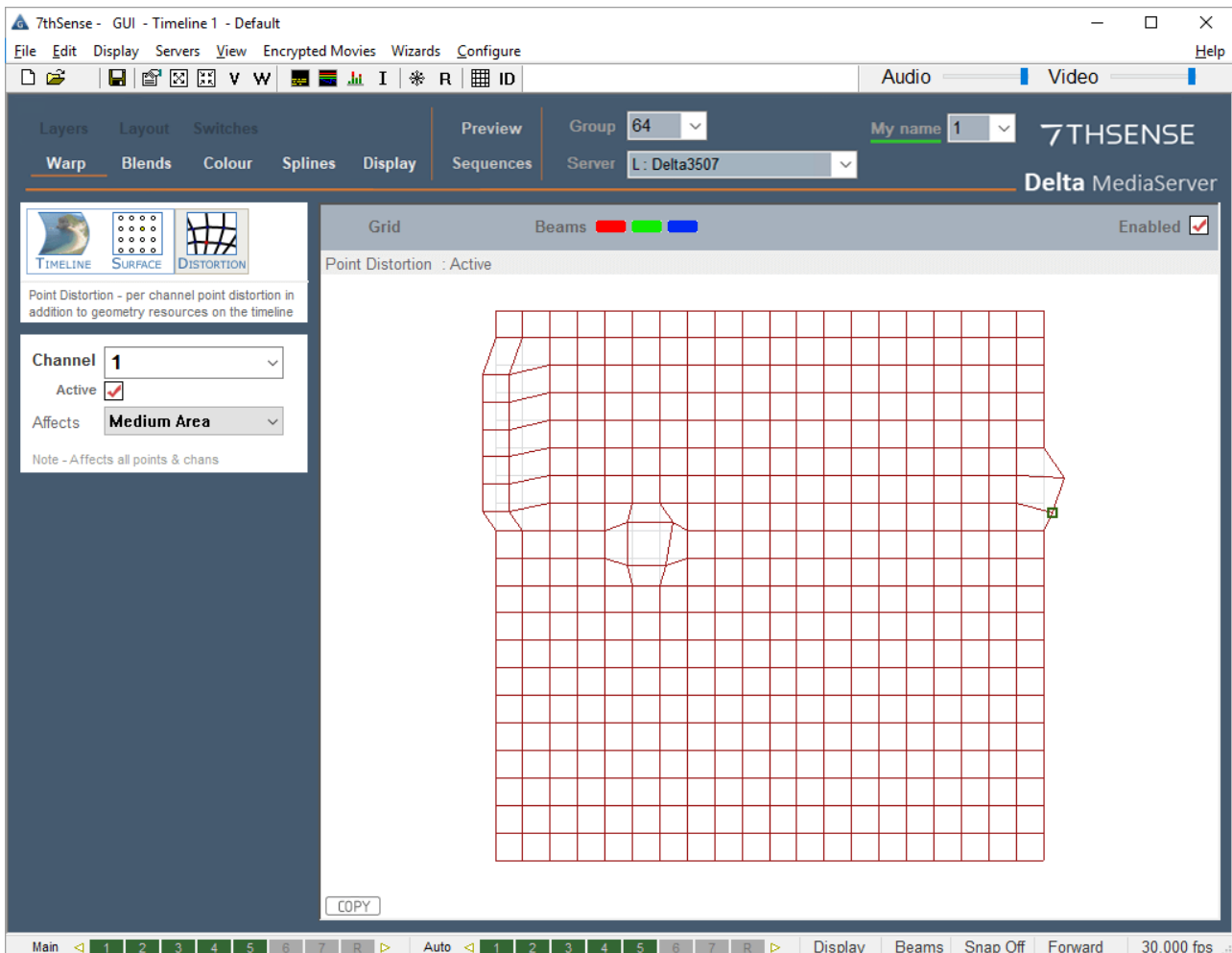

Single or selected points are moved in DeltaGUI, whilst viewing the display; moving a single point smoothly affects those around it to a certain degree so that sharp changes in direction are minimised. Use the **Affects** selection for how far spread the distortion needs to be, before starting the adjustment. Medium is recommended for the range of influence for 11 × 11 grid density, small for 21 × 21.

## Point Selection

- Single node: move from node to node with the arrow keys; the selected node is yellow. You can clicking to select, but this is likely to nudge the point.
- Multiple nodes: rubberband over a number of points and move them as a group. To add groups, press Shift, then rubberband over further points.

In this example below, you can see the distorted part of the image around the yellow (selected) point:

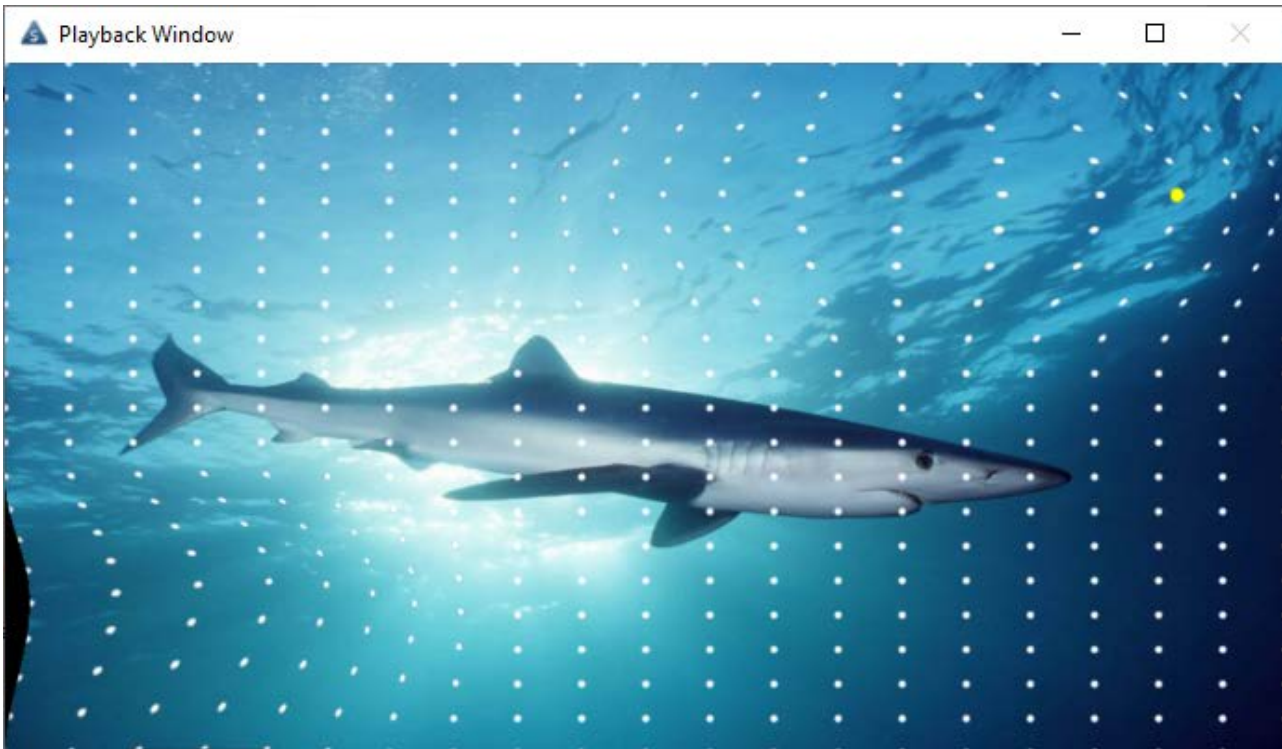

- For large movements, use the mouse to select the point or points, and drag to the new location.
- For small and precise adjustments, use the arrow keys to select the point, then press Ctrl and use the arrow keys to move the distortion of that point.

Once finished aligning the geometry, return to the **Timeline** image source.



## Grid Menu: Reset Distortion

To reset a group of points, rubber band over them to select them, click the **Grid** button then choose **Reset Selected Points** from the menu.

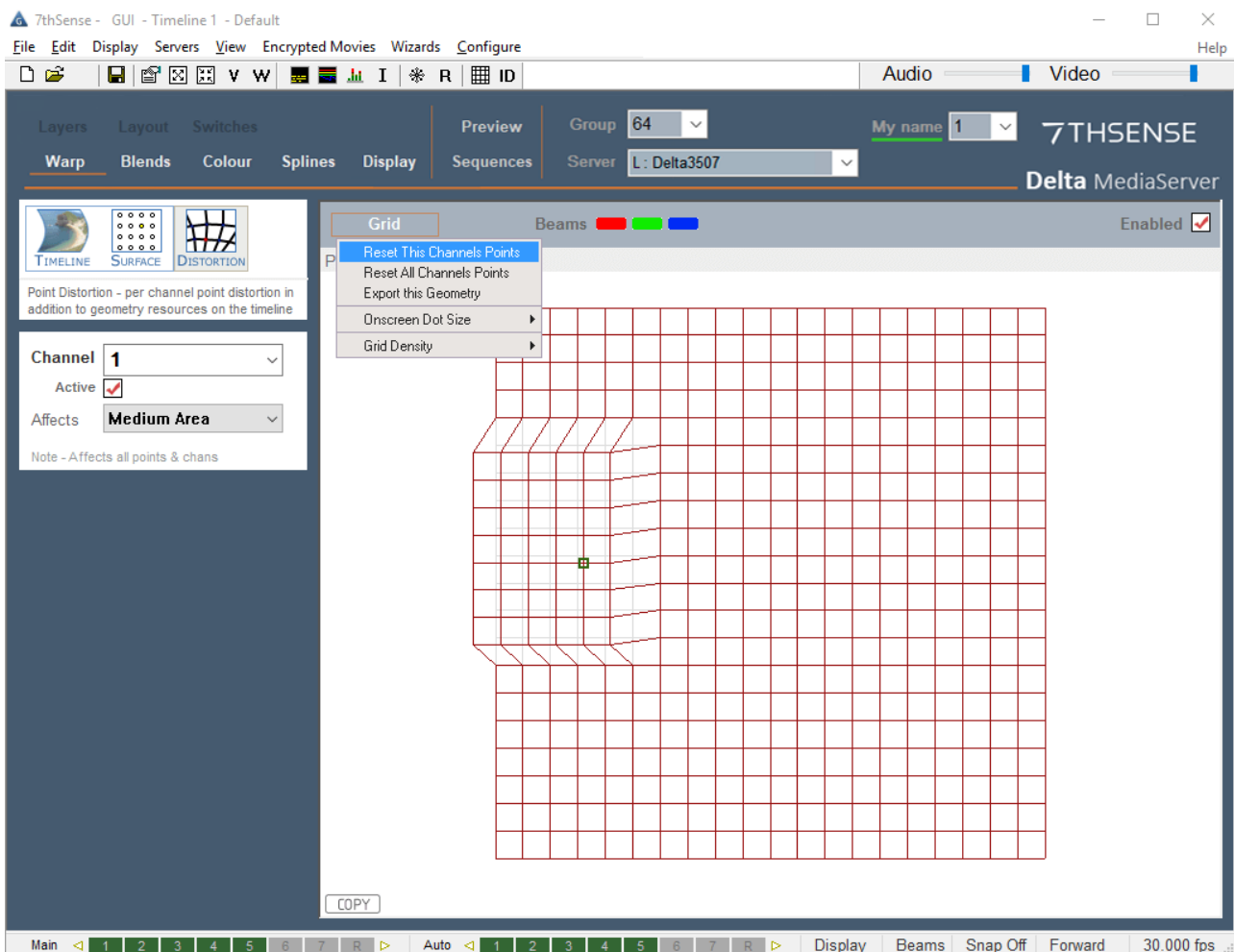

Reset This Channel's Points or All Channels' Points

## Grid Menu: Export this Geometry

Export this Geometry to use in other applications which use the warp:

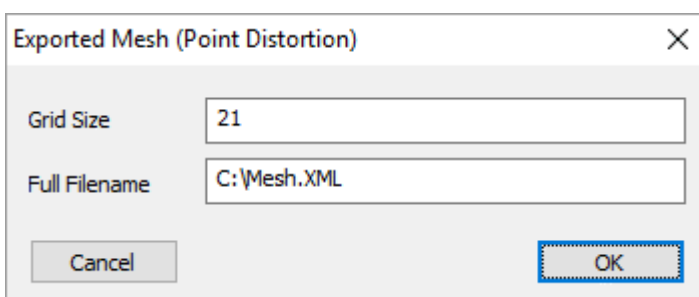

## Grid Menu: Grid Density

You can swap from the default 21 × 21 grid to an 11 × 11 grid using the *Reset menu > Grid Density* item.

**Note** that this will reset all point distortion on all channels on this server.

## Grid Menu: Dot Size

You can choose larger than the standard dot size if the dots are hard to see.

## Copy Distortion

To copy the current channel's distortion to another channel, press the **COPY** button in the lower left corner and type in the destination channel.

## Display Configuration: Blending

---

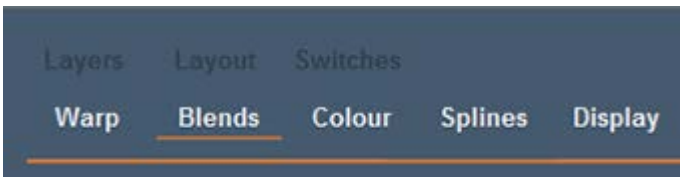

Delta implements simple edge blending, to allow overlapped display systems to be blended together, forming a single continuous display surface. By combining edge blending with warping, Delta can be aligned to any display system with no additional external hardware.

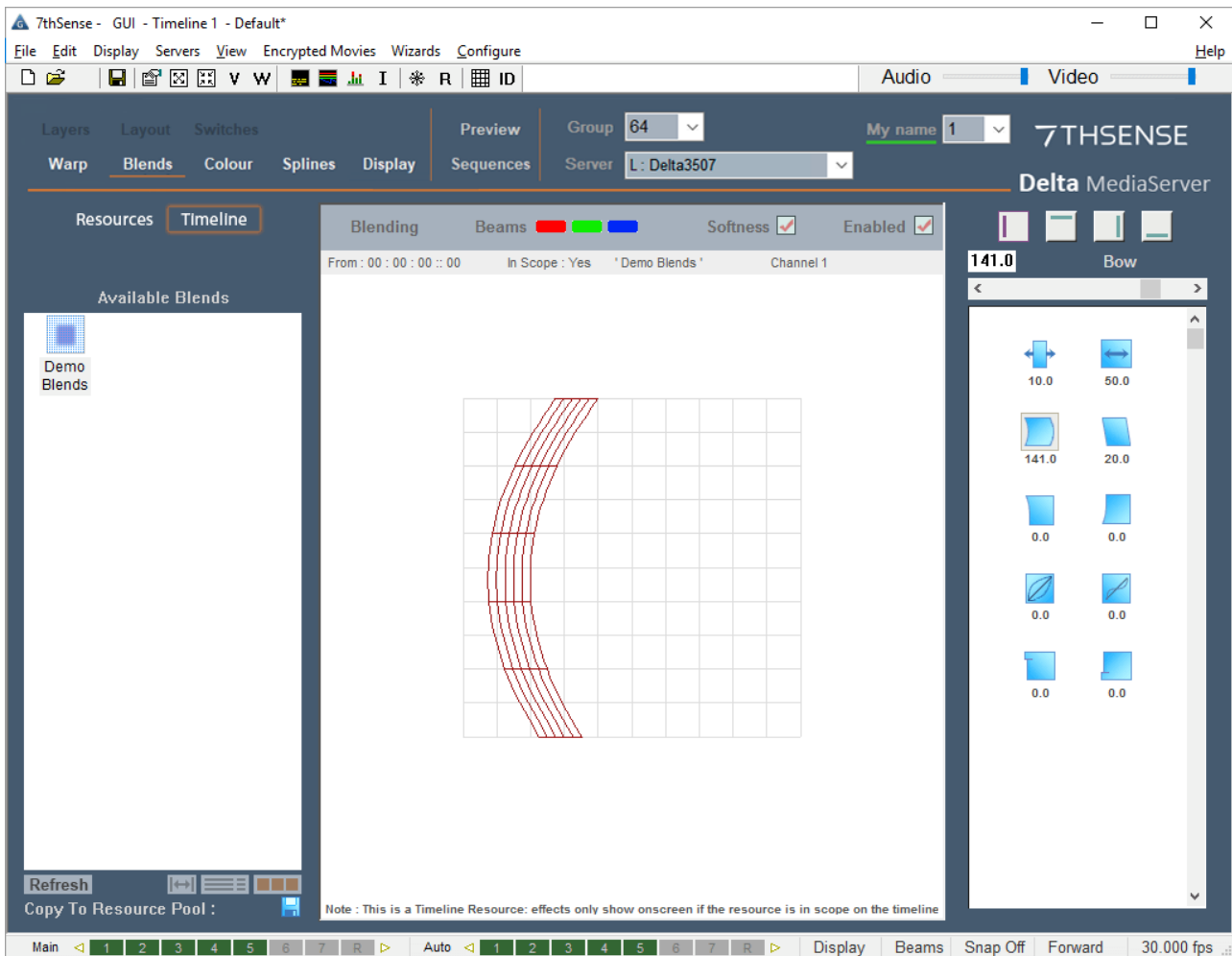

The Edge Blending page allows you to tune each blend (Left, Right, Top and Bottom) for position, softness, bow and keystone, as well as gamma and smoothness (s-correction). Blend Limits allow you to stop the blend at a hard edge part way through the image (used on some complex blends).

To edge blend a system, ensure softness on overlapping blends is the same, make the edges parallel, then tune the position and gamma to make a seamless blend.

A good blend is highly dependent on the fundamental display matching, so ensure the luminance and colour match between the adjacent display channels is as good as it can be.

A blend can be inverted (edit the resource on the timeline, Timeline tab), so the black part is in the middle of the channel, soft edges are outside this. This is used when blending insert channels which are blended to surrounding channels

- The Enabled button allows you to temporarily disable this group's blending.
- The Softness button toggles between a hard edge or correct softness for this group so you can match up the two adjacent blends with a hard edge, then enable the softness to see the result. This is a temporary condition which is not saved to the file.
- If you put two blends (same channel) on the same frame, they will multiply together, so you can create complex blends using multiple blends.

- On the Mesh page of the resource editor (only available whilst in Mesh Mode), choose between normal **Channel** blending or apply the blend to the **Source Texture** from the **Blend Target** drop-down menu.

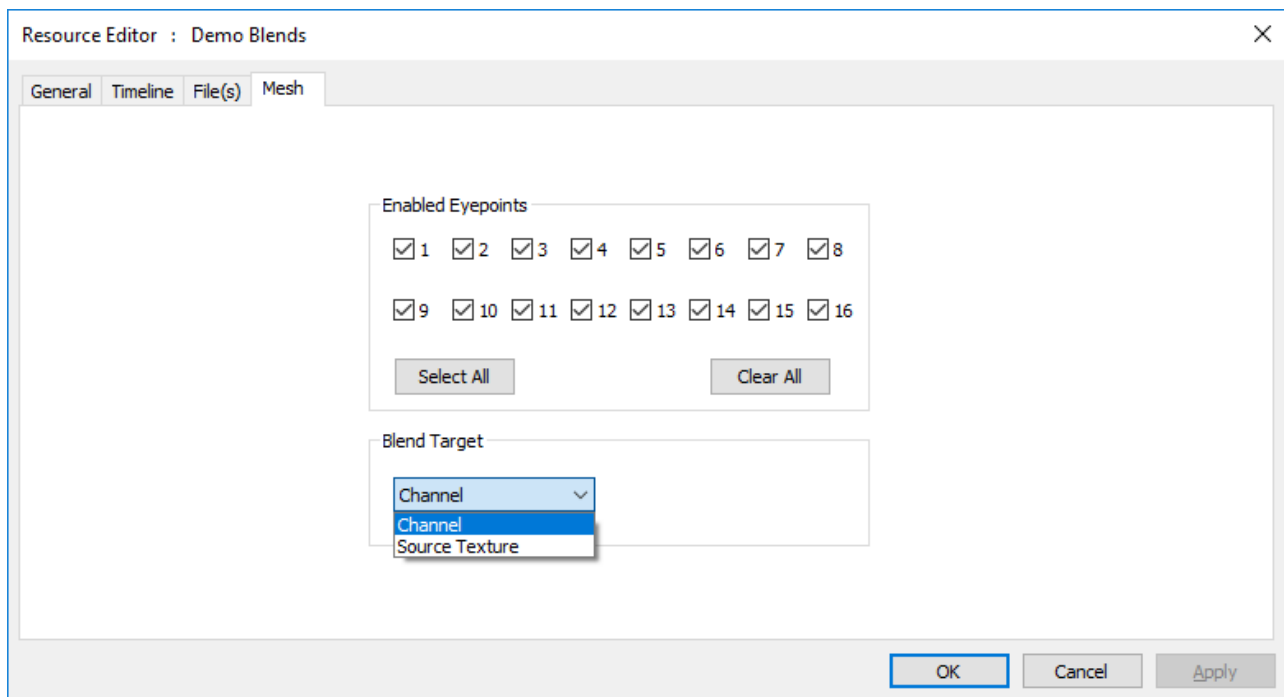

This is used to apply blending on the 3D model between different media and can be used in conjunction with other blends set to Channel mode for standard projector edge blending.



In the example below, blending has been applied to a cube mesh with 2 channels. The first image shows what happens when the blends are applied to the whole **Channel**, whilst the second image shows how blends are applied to the **Source Texture** 3D mesh.

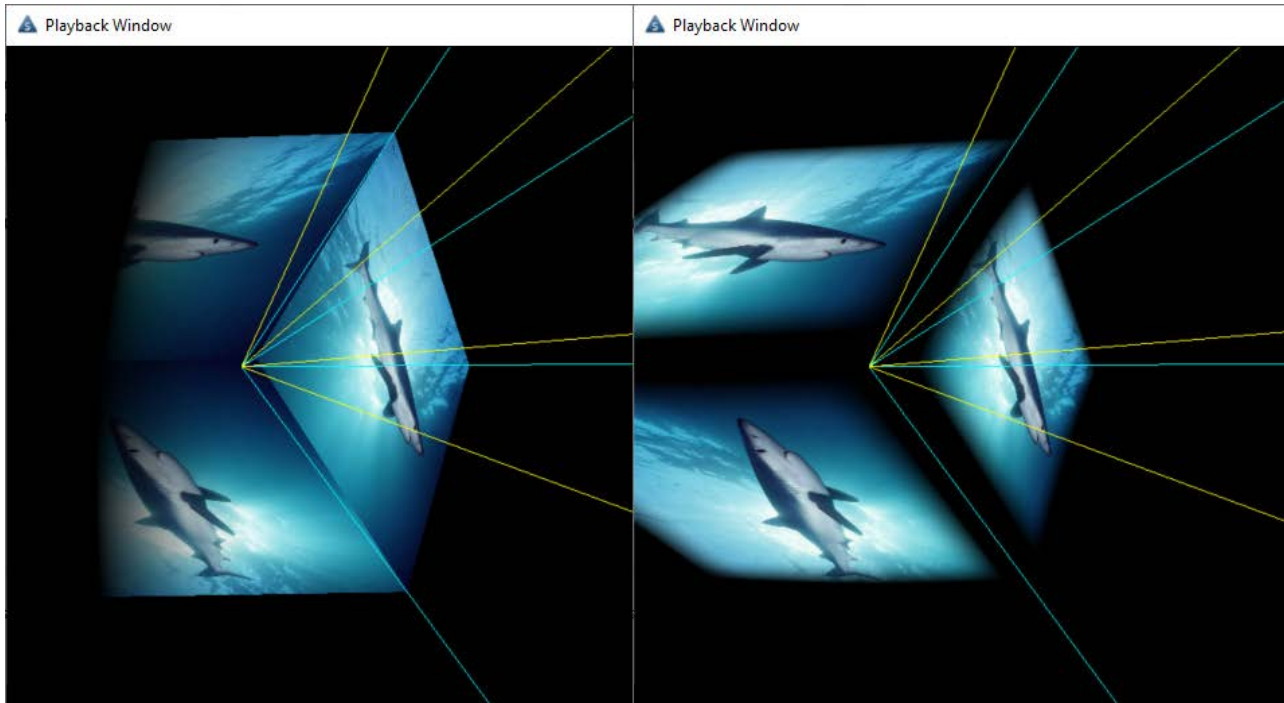

For more information on Mesh Mode, including Mesh Editing functionality, see [Display Configuration: Mesh Mode](#) <sup>221</sup>.

- Blend resources can also have Fixed enabled – this will auto-reset the start frame of this geometry to frame 0. If Fixed is disabled, you can set the start frame as normal.

## Display Configuration: Colour Balancing and Convergence

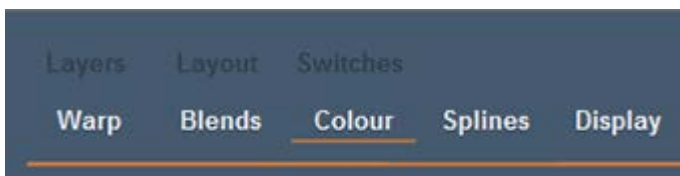

Adjacent channels may not be accurately colour matched. To change the colour of a channel, you must first add a flat colour resource to the timeline (background layer), assign it to a channel, and then adjust it here whilst observing it on the screen. Note that if the projector supports higher bit-depth colour adjustment, it should be carried out in the projector in preference.

In the *Display Configuration menu > Colour*, tune the overall (flat) colour of the image using the Black/White contrast button.

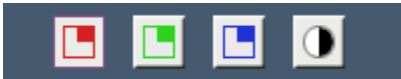

Then adjust the brightness and gain (contrast) for each RGB colour (or overall) and gamma can be also adjusted. The central image in this page is a static reference only.

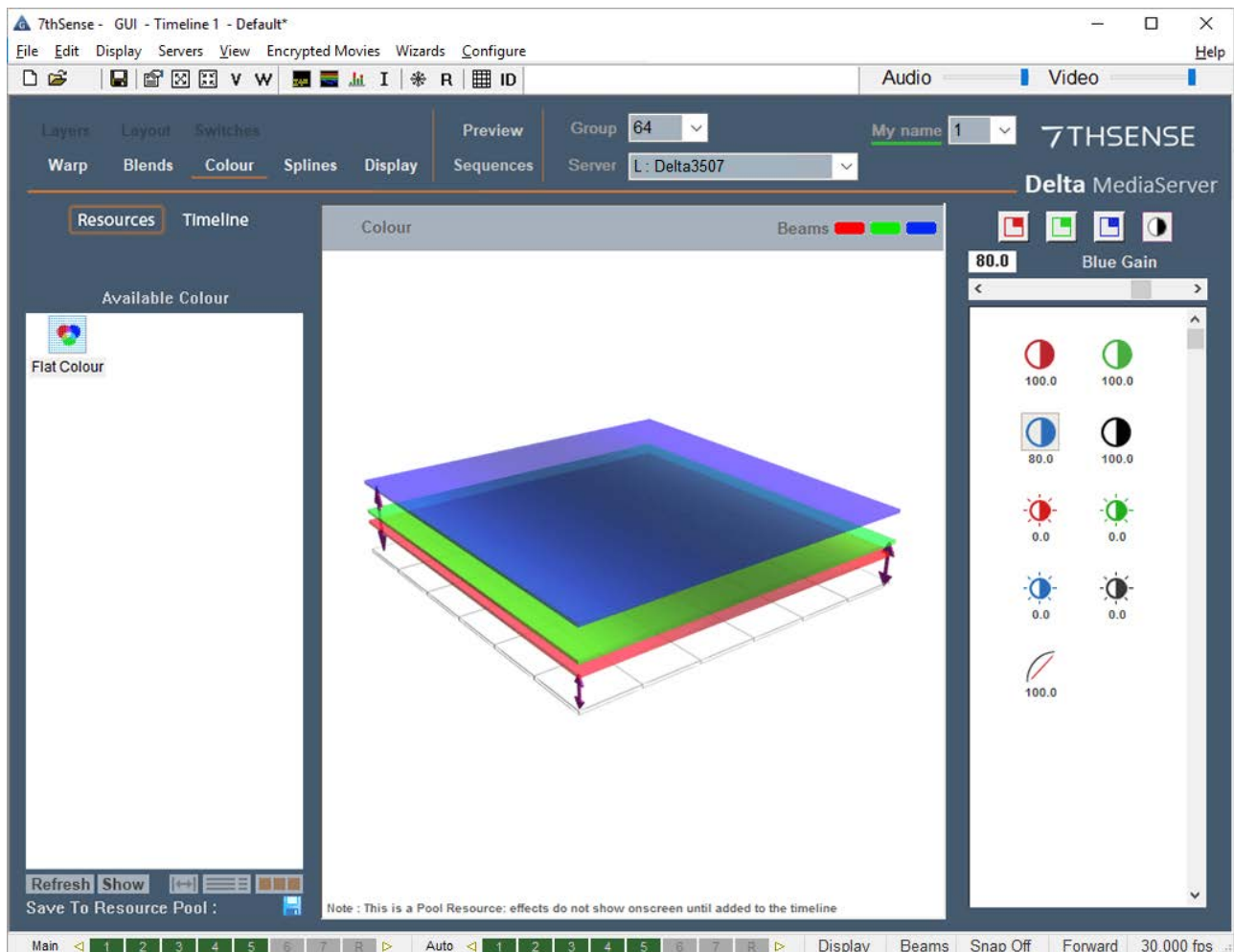

If colour or luminance drop-off to the image edges is not good enough, select the RGB square buttons:



Then pick which side to increase or decrease in luminance for that colour. The centre of the picture is unaltered, with increasing adjustment to the side you picked. Here, left edge, red colour adjustment is selected:

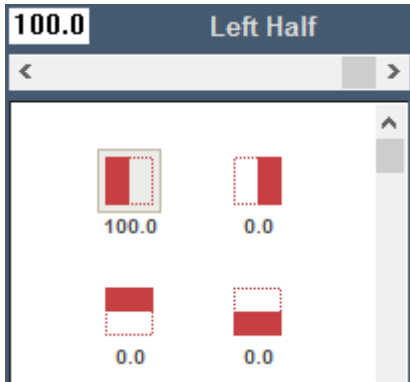

## Colour Balancing Sequence

The normal sequence of operation in matching a multi-channel display system is:

- Choose a rich, full-screen image with all colours present.
- Observe the centre of each channel, and use the White colour controls to match the centre luminance and colour.
- Observe the edge between channels, and use the relevant edge colour shading control to match the colour and luminance at that point.

This is typically used to match colour and luminance across multi-channel display systems.

## Display Configuration: Splines

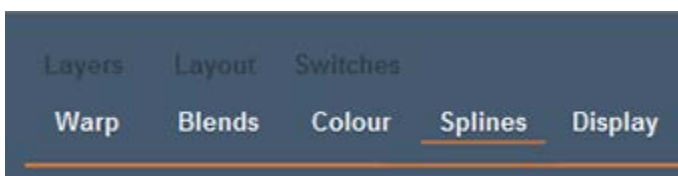

Spline resources can be applied to any layer, including the background. They comprise a series of Bezier curves along which the top-left (optionally the centre) coordinates of a media resource travels. The motion can be A to B, or 'Ping-Pong' A to B to A, and can be set to repeat any number of times. Default splines are supplied, which can be edited and saved back as resources to the pool.

To alter Ping-Pong, repeat count, and advanced timing of each node, edit the resource on the timeline.

### Ping Pong

When this is enabled with a repeat count greater than 1, instead of simply repeating the move, starting at the first node again, it will reverse course along the spline until the start, then reverse again, ping-ponging direction.

### Repeat Count

By default, this is 1, where the whole length of the spline is travelled over the length of the spline resource on the timeline. With a count of (for example) 4, it will travel 4 times over the spline path in the same length of the spline resource on the timeline.

## Spline Properties

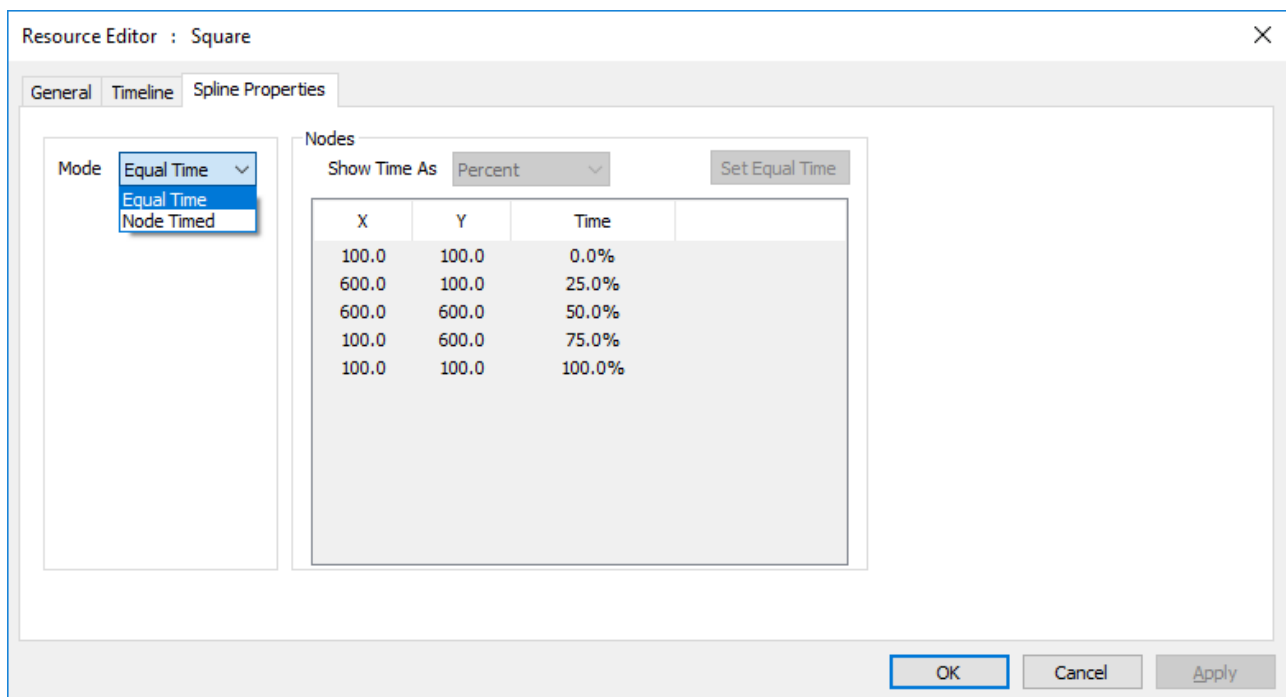

In **Equal Timed** mode, each node is given the same fraction of time allocation as set by the length of the spline resource on the timeline. For example, with 5 nodes, the 5th node will be reached at 100% of the length, the other nodes at 0, 25, 50, and 75%.

In **Node Timed** mode, you can edit the fraction of time for each node, as long as they all add up to 100%. For example, you can set the 5-node example to 0, 12, 13, 75, 100% so that the 2nd node will be reached after 12% of the resource length, the 3rd node after a further 1% (a quick move), then the 4th takes  $75-13 = 62\%$  (a slow move) of the length.

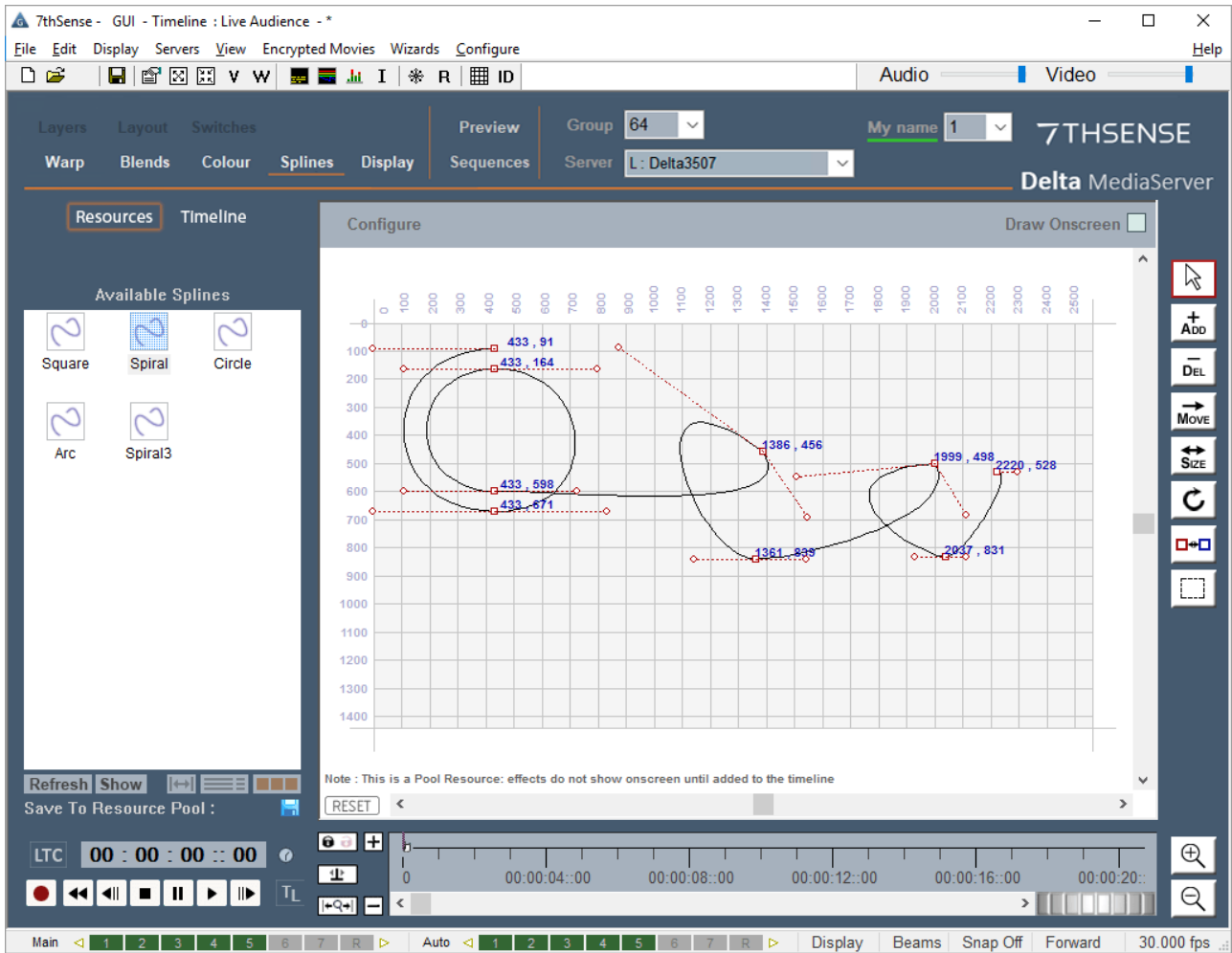

## Spline Controls

You can select the spline in the Timeline tab of the resource window, then using the controls in the right panel, add nodes, remove them, move nodes and node controls around, until the shape is as required.



Move a node or node control  
(Press the Control key to restrict movement in X or Y)



Add a node to the end or insert a node in the middle of a spline



Delete a node



Move the entire spline



Resize the entire spline



Rotate the entire spline



Toggle a node from symmetric control nodes to separated control nodes



Rubber band selection of a number of nodes  
(Press the shift key to add to the selection)

**Note** you can also zoom in and out using the mouse wheel:



Zoom into the canvas



Zoom out from the canvas

In certain modes (Move, Delete, Toggle Node Type), dragging on an empty part of the canvas allows you to drag the canvas around to navigate more easily.

## Draw Onscreen

With this checkbox selected, the spline path will be shown as a tracking line in the playback window when the spline resource is in scope. In addition, parts of the spline to the left of the playhead are shown in yellow, future parts in red so you can see how far through the spline the resource is.

## Spline [Configure] Menu

Click the [Configure] button on the splines page for the following menu options:

### Reset Spline Location

This will move the spline so that the first node is at 0,0 in order to put it back on the canvas – it does not change the shape of the spline

### Limit Spline to Canvas

This will move any node which is off the canvas onto the canvas – note that this will change the spline shape.

### Show Node Coordinates

Enables the drawing of the pixel coordinates of all nodes

### Show Node Order

Enables the drawing of the node order

**Mirror Spline Horizontally / Vertically**

Mirror the spline horizontally or vertically

**Rotate Spline**

Rotate 90 Clockwise, 90 Counter Clockwise or 180 degrees.

**Undo / Redo**

Pressing Ctrl+Z will Undo and Ctrl-Y will Redo up to the last 20 changes to each spline.

**Show VCR Controls**

Show the playback controls and timeline, to enable moving the play head.

**Snap**

Enable or disable snapping points to the grid at preset grid sizes.

**[RESET] Button**

Resets the view position so that the canvas is shown full screen

**Save to Resource Pool**

This button in the resource window allows you to alter a spline, then save it to the \Splines folder as a template for future use.

**Note** that Splines only work in Flat or Mesh mode (not Dome Mode).

## Display Configuration Files (XDL files)

---

When choosing 'File > Save As' you have the option of saving a Display Configuration file (choose this in the 'Files of Type' dropdown box). This file contains a subset of the current server's settings, which relate to the display configuration.

You can load an XDL file at any time onto an existing show. This merges the display configuration in the XDL file with the current timeline contents, which allows you to keep display configuration separate from the show.

**An XDL file contains:****Display Settings**

Canvas size, active channels, channel sizes, timeline length and framerate, geometric mode, display gamma, beams, geometry and softness enable flags.

**Background Geometry**

Only those geometries on the background layer are saved in an XDL file.

**Blends**

If present, any blends are saved to the XDL file.

**Colour**

If present, any colour corrections are saved to the XDL file.

**Note:** an XDL file is merged with the current file. Any existing background resources (warp, blend, colour) present in the first 10 frames of the timeline are deleted, before any of those resources are merged from the XDL. Any of those resource types present after the first 10 frames will not be altered.

**Permanent Geometry**

You can specify an XDL file which is loaded after any file load so that the display configuration, point distortion and background geometry, blending and colour is maintained across show files even though this is not saved in each show file.

In DeltaGUI menu: *Configure > Preferences > System*, browse to the XDL file which is to be loaded each time. This is stored in the registry.

With a permanent XDL file defined, the behaviour of this process is on any file load:

- Load the Show XML file as normal
- Delete any geometry, blends and colour found in frames 0-9 on the background layer
- Merge the XDL file

You can also set the XDL file from external control if you want to swap between different permanent geometry setups:

```
SETDISPLAYCONFIG "C:\program files\7thsense\delta\setup1.xdl"
```

or

```
SETDISPLAYCONFIGALL "C:\program files\7thsense\delta\setup1.xdl"
```

to set all in that group to the same XDL file.

**Note** that a popup shows in DeltaGUI to highlight when an XDL is loaded.



## Display Configuration: Flat Plane Mode



### FLATPLANE MODE

In this mode, projected images are co-planar: i.e. they are on the same flat (or curved) screen surface.

In Flat plane mode you can have up to 64 channels (dependent upon licence options), which show any part of the **canvas** (the full display area including all Delta output channels), up to the full canvas (or over-scanned) and down to very small areas of the canvas. Click the **C** button to select active channels:

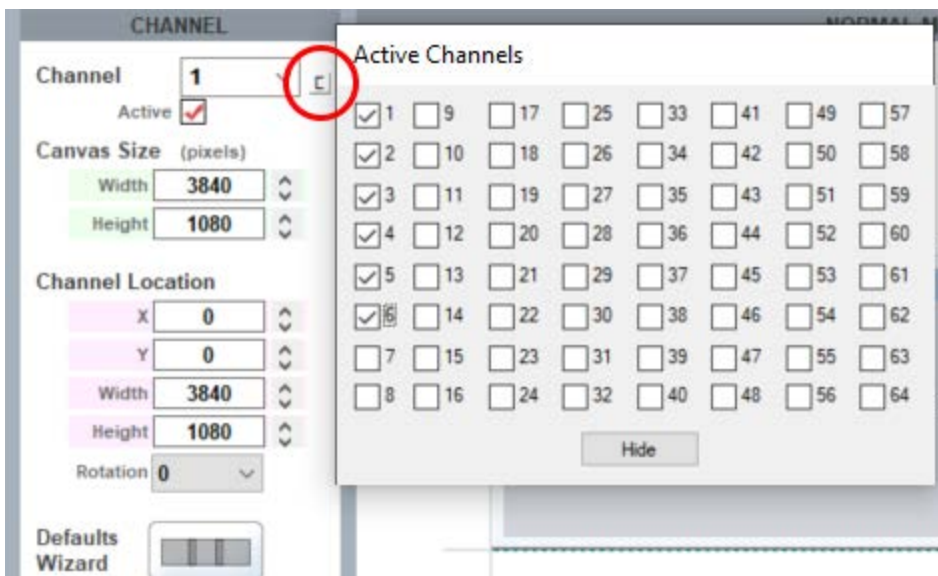

You can think of a channel as a window onto anywhere in the entire canvas, for instance a small channel will only fill a small part of the entire canvas.

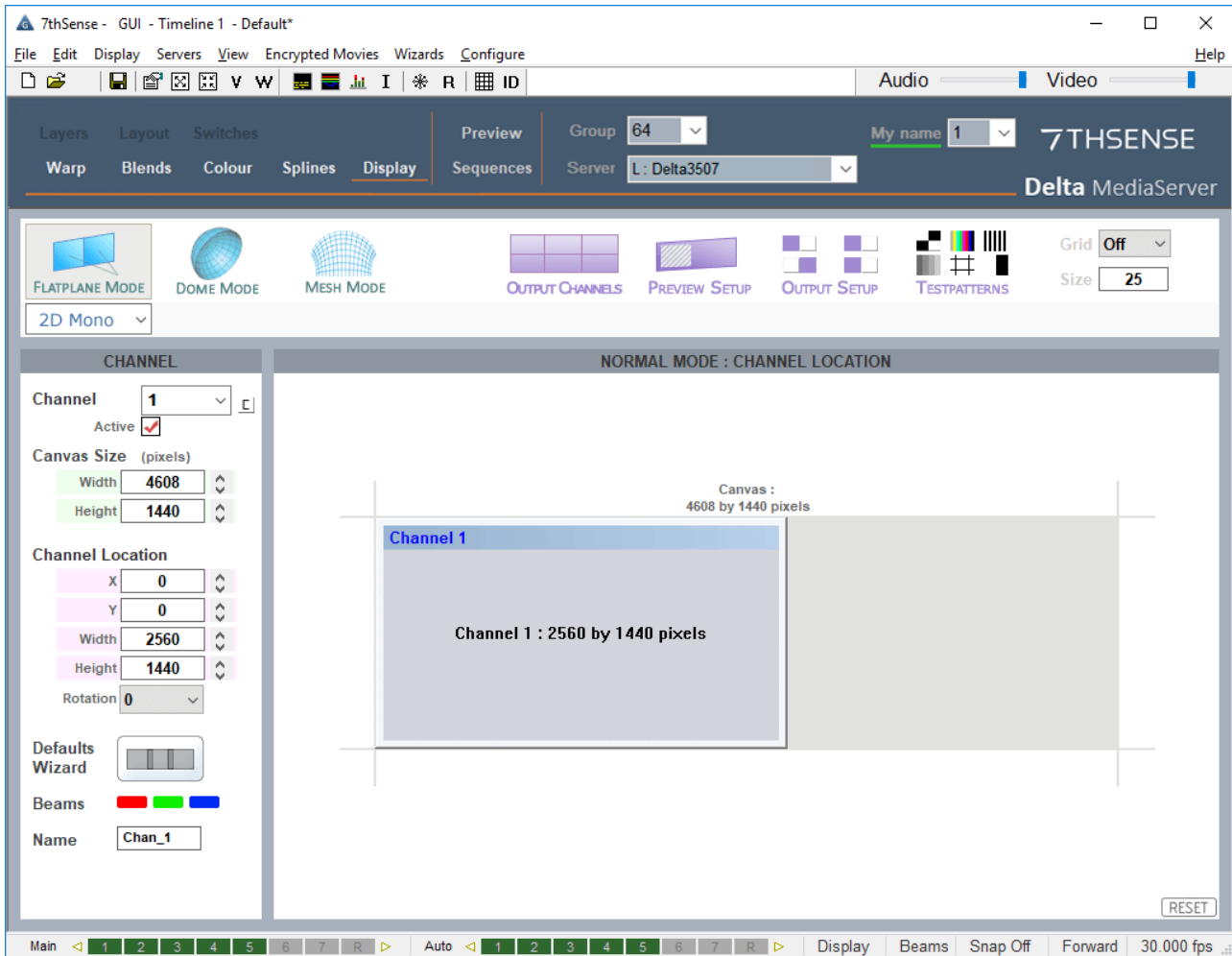

In the example above, the canvas is set to a nominal  $4608 \times 1440$  pixels (it can be any units to suit your need), and two channels are defined: Channel 1 is shown as a blue rectangle covering half the canvas, Channel 2 covers the other half, with an overlap for blending of 512 pixels.

These channels can be independently sized or rotated by any angle to match the display orientation.

Each channel can be dragged and resized onto the canvas here. These illustrations show the effects in a 3-channel panoramic display in DeltaGUI and the playback window.

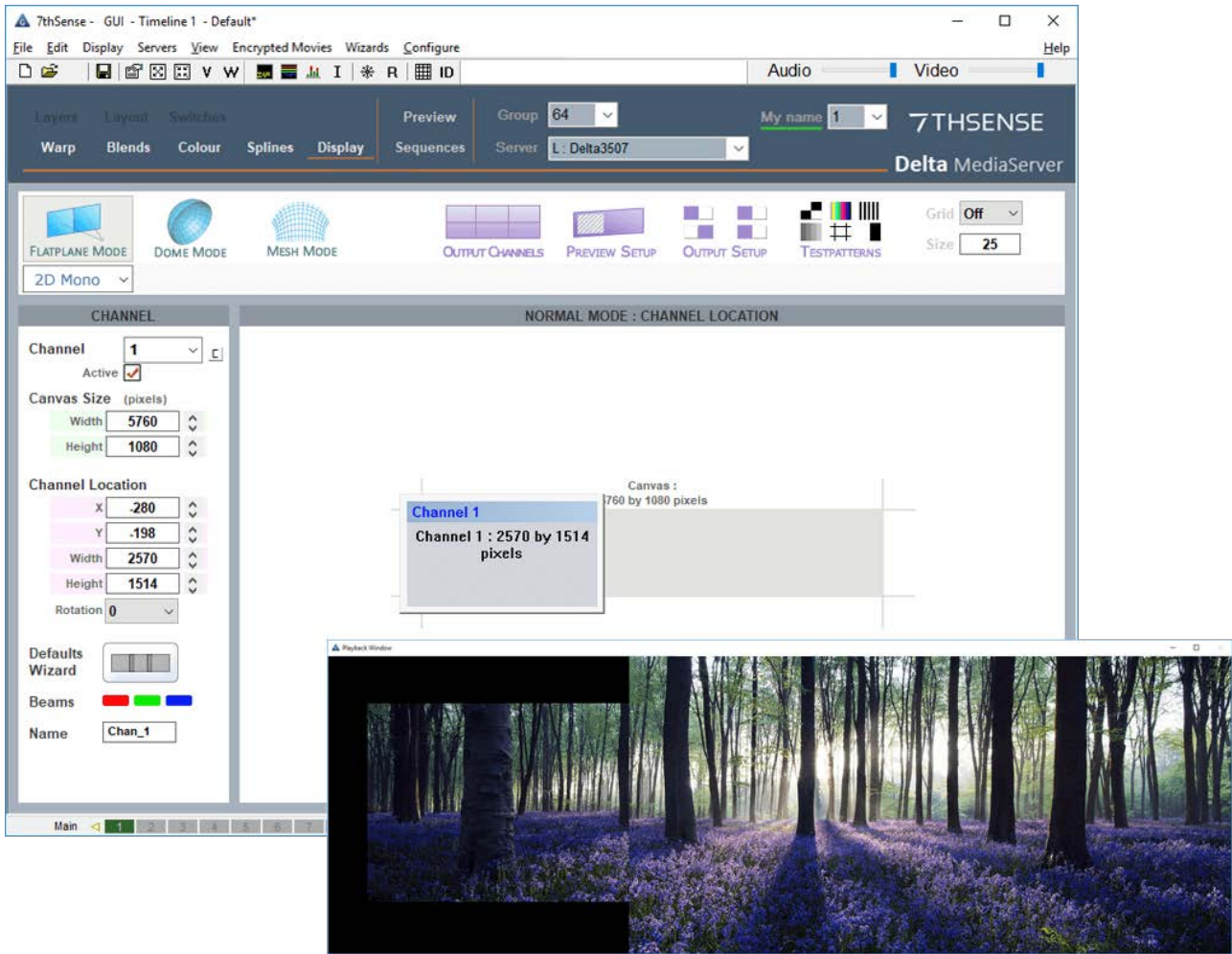

▲ Channel 1 has been oversized to the canvas

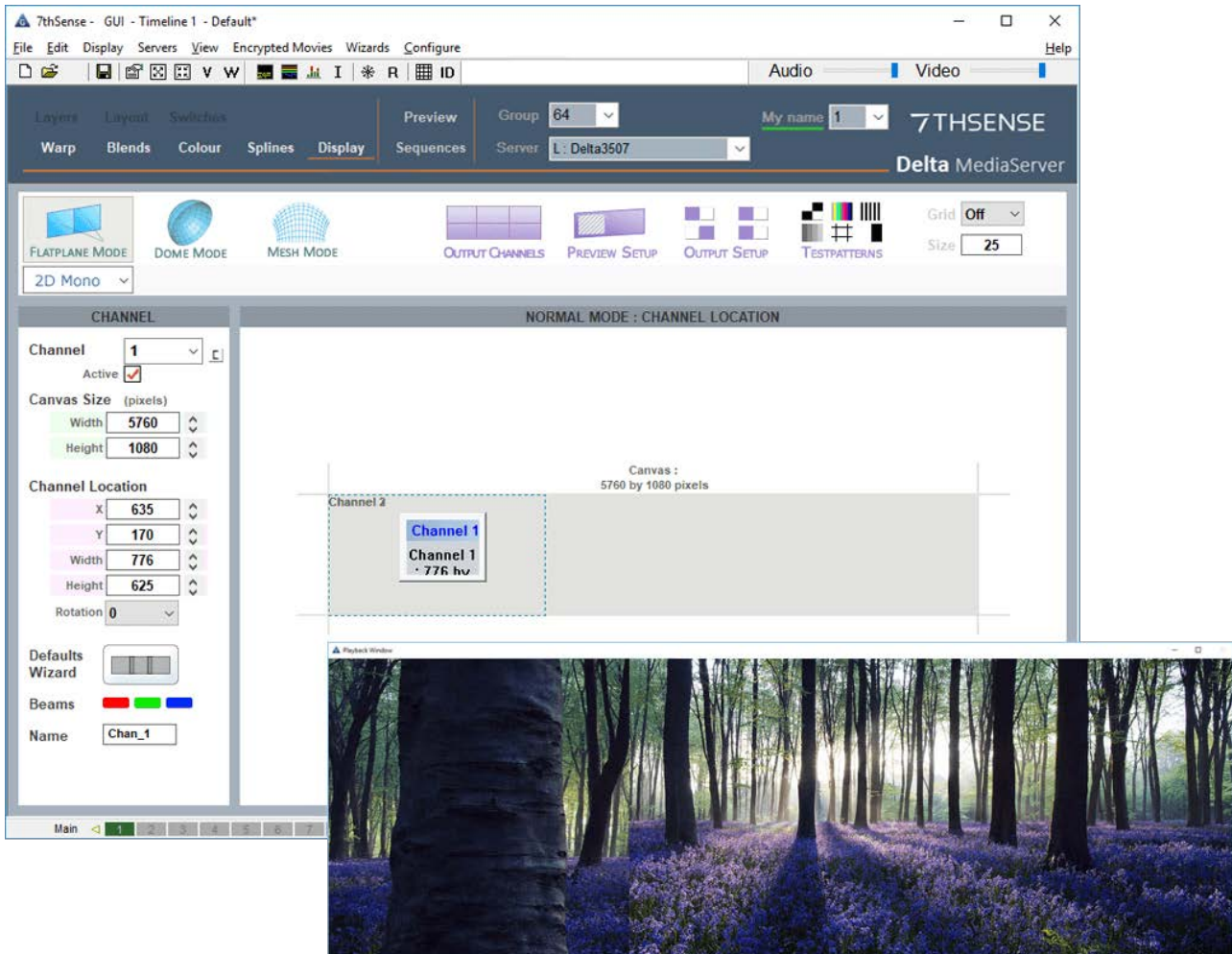

▲ Channel 1 has been undersized to the canvas

## Dynamically Resizing Channels using Sequences

External control commands can be used to trigger channel resizing, using [sequences](#)<sup>354</sup> on the timeline.

*Example:*

```
$startblock
SETCANVASSIZE w=32 h=32
CHANNELMOVE num=1 x=0 y=0 w=32 h=32
$endblock
```

```
$startblock
SETCANVASSIZE w=1920 h=1080
CHANNELMOVE num=1 x=0 y=0 w=1920 h=1080
$endblock
```

## Flat Plane Channel Arrangements

---

### Edge-Butted Display

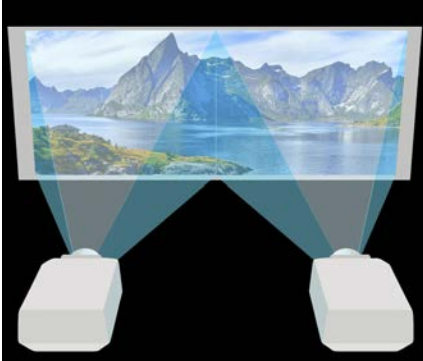

In this configuration, each picture is lined up to its neighbour exactly along a common edge. In Delta, Set Channel 1 and 2 to exactly half of the canvas size, and set Channel 2 to have an X Offset of half the canvas size. No blending is required for this system.

You can either type in the figures manually, or use the Defaults drop-down list and choose Horizontally Edge Butted to automatically calculate the figures.

In the example below, Channel 2 is shown with an X offset of half the canvas width.

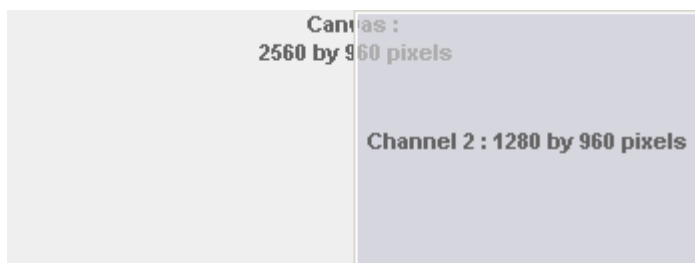

### Overlapped Display



In this display, the projected images are physically overlapped (usually by a minimum 10%), then a blend is applied to the left and right edges to provide a seamless display.

You can either type in the figures manually, or use the Defaults drop-down list and choose Horizontal 10% Overlap to automatically calculate the figures.

In the example below, the canvas is set to 2304 pixels wide, with Channel 2 shown with an X offset of 1024, leaving a 256 pixel overlap between Channels 1 and 2.

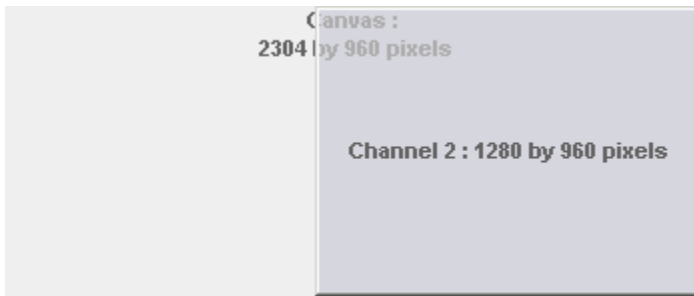

### Underlapped (Bezel) Display

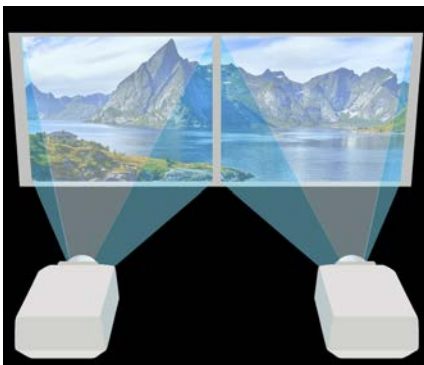

In this display, the projected images have a physical gap, so the Delta imagery must also have a gap otherwise things will not 'disappear' properly in the gap.

A typical example of this arrangement is two or more display-wall panels butted together, rather than projectors as illustrated. Due to the bezel around the panel edge, there is always a significant gap between adjacent channels, so the underlapped configuration can be tuned to provide the correct imagery.



## Flat Plane Output Channels

The Output Channels button shows the channel layout, with a representation of all active channels. This is a flat plane mode array of 6 channels. If a channel is made inactive, the display will adjust to best fill the canvas.

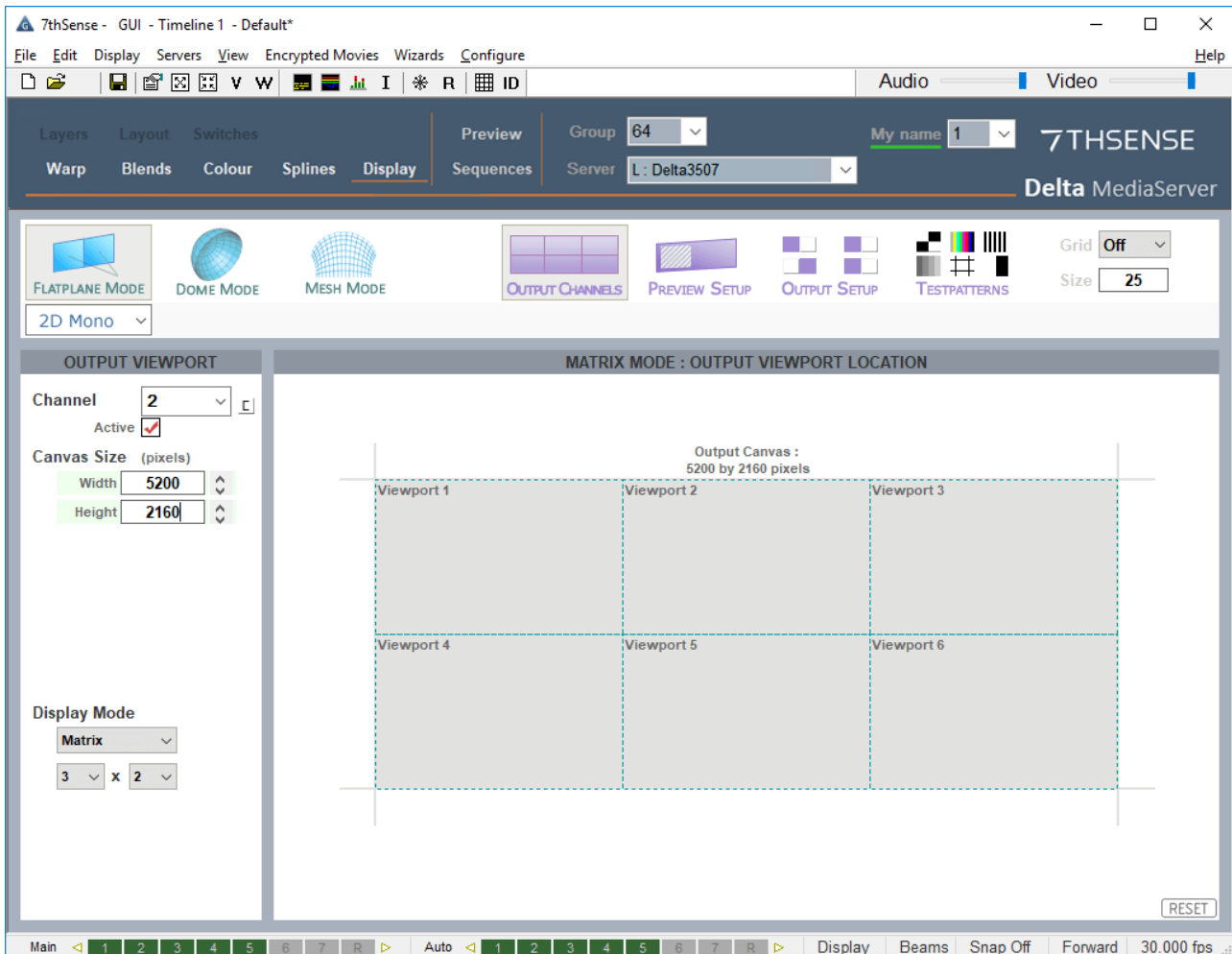

### Display Mode

This replicates the settings in the Defaults Wizard (see [Flat Plane Mode Defaults](#)<sup>(169)</sup>).

## Flat Plane Preview Window Setup



Set the area you wish to see in the Preview window. You can do this while viewing the actual Preview window.

Click the Preview Setup button and then type in or drag the preview location XY (top left corner coordinates), width and height values (and/or rotation). This location is independent of any output channel.

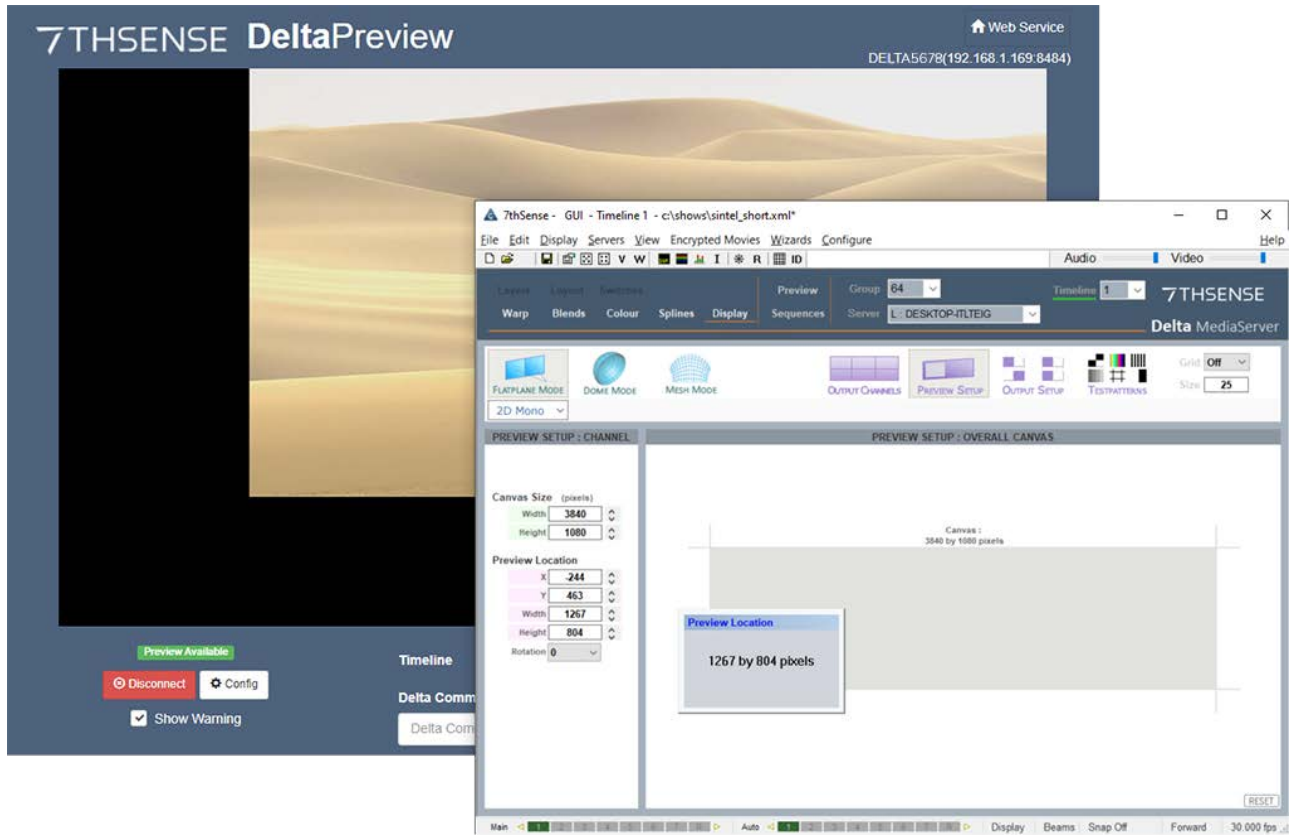



## Flat Plane Mode Defaults

Press the Defaults Wizard button to view the configuration dialog:

From this dialog, you can arrange channels in a horizontal line, vertical line, or X by Y grid of channels. You can also choose to edge butt the channels (no overlap) or set the overlap in pixels or percentage of channel width.

### Canvas

#### Rescale Canvas

will resize the canvas when overlap is introduced, for example reducing from  $2560 \times 1024$  to  $2432 \times 1024$  for 2 channels 10% overlapped. You can choose to leave the canvas size fixed instead – in this case, channels will be resized to fit.

### Channels Used

Assign the number of channels required (or if editing an existing display configuration, use existing).

## Channel Arrangement

In most cases, match the channel matrix applied to your desktop display arrangement as set in the graphics card configuration on the server.

### Overlap

#### Edge Butted

is typically used for displays which have no overlap.

#### All Overlapped

creates multiple channels which all look at the same canvas, but can have different distortion / blending – ideal for stacked projection.

#### Overlapped

is used for overlapped projection.

#### Underlapped

is used to remove the gap created by bezels between fixed-matrix panels.

## Channel Size

Channel size can be Forced to a user value or in 'Use existing size', will be taken from the graphic card's information.

## Add Warps and Blends

For **Overlapped** channels, you can choose **Create Warp** and **Create Blends** options. Create Warp will add a flat (non-distorted) warp resource for each channel and Create Blends will insert nominal blends in the right place as a starting point. Note that existing warp and blends will be removed from the timeline on the selected server.

## Process: Flat Plane Align, Warp and Blend

---

Any non-perpendicular projection requires a degree of warping in order to correct for perspective. This procedural guide covers flat plane screens – which includes curved screens, but not spherical surfaces – and uneven surfaces, but not polygonally-mesh-mapped ones. Once set up, the display configuration for the theatre can be saved and loaded separately, to be merged with any show.

## Three Adjustments per Channel: Shape, Overlap Brightness, and Colour

The basic principle is that since the canvas as a whole is divided into areas covered by several channels, each channel will require its own correction by warping to maintain both aspect ratio and perspective. The channels will need to overlap for smoothest continuity, corrected for luminance by blending, and differences in characteristics between projectors may finally require correction for colour.

- **The alignment task** is about mapping a seamless, evenly-proportioned grid, across all channels, onto the physical canvas, without distortion, duplication or cropping, using the various warping tools.
- **The blending task** is about making the joins between channels invisible through luminance blending and colour correction.

In the example used here, projectors are in line, but other configurations are possible.

## Physical Setup and Tools

We assume here that the theatre setup has provided you with enough information to know media size, physical canvas properties and degree of overlap between channels, and that best efforts have been made already in aligning projectors correctly. The procedures outlined here will apply every time readjustment is necessary, for example following regular maintenance.

Since one of your key tasks will be to ensure that the size and aspect ratio of every grid square is the same, some basic tools will be useful, including, for example, a laser line (to find true horizontal and vertical) and a tape measure.

Autoalignment, such as Scalable Display Manager™, is a practical though more expensive solution, but for more complex surfaces may be worthwhile (enable this in *Config* > [Startup & File Load](#)<sup>95</sup>).

**Please note: AutoAlignment is a licensed option.**

## Sequence in DeltaGUI

- Know your canvas size, your overall media size, the approximate channel overlap, and how your channels are distributed.
- Use the information in the Defaults Wizard to distribute active channels, positions, and overlap for Delta, and to generate default background warps and blends.
- Turn on the pixel grid display, and adjust channel X and Y locations, and overlap to bring the defaults approximately into line with reality.
- Adjust each channel for proportion and linearity, and align each channel to the next, using surface, timeline and point distortion warp.
- Display test patterns or flat colour media in order to apply blends and adjust overlap luminance.

- Save the .xdl display configuration file to use for any show in this configuration.

## Process: Setting Up Channels

In DeltaGUI, start a new show (*File > New*), clear of all resources and configurations. Check in *Display > Output Setup* that the **Output Channel Mode** is Off (All In Line).

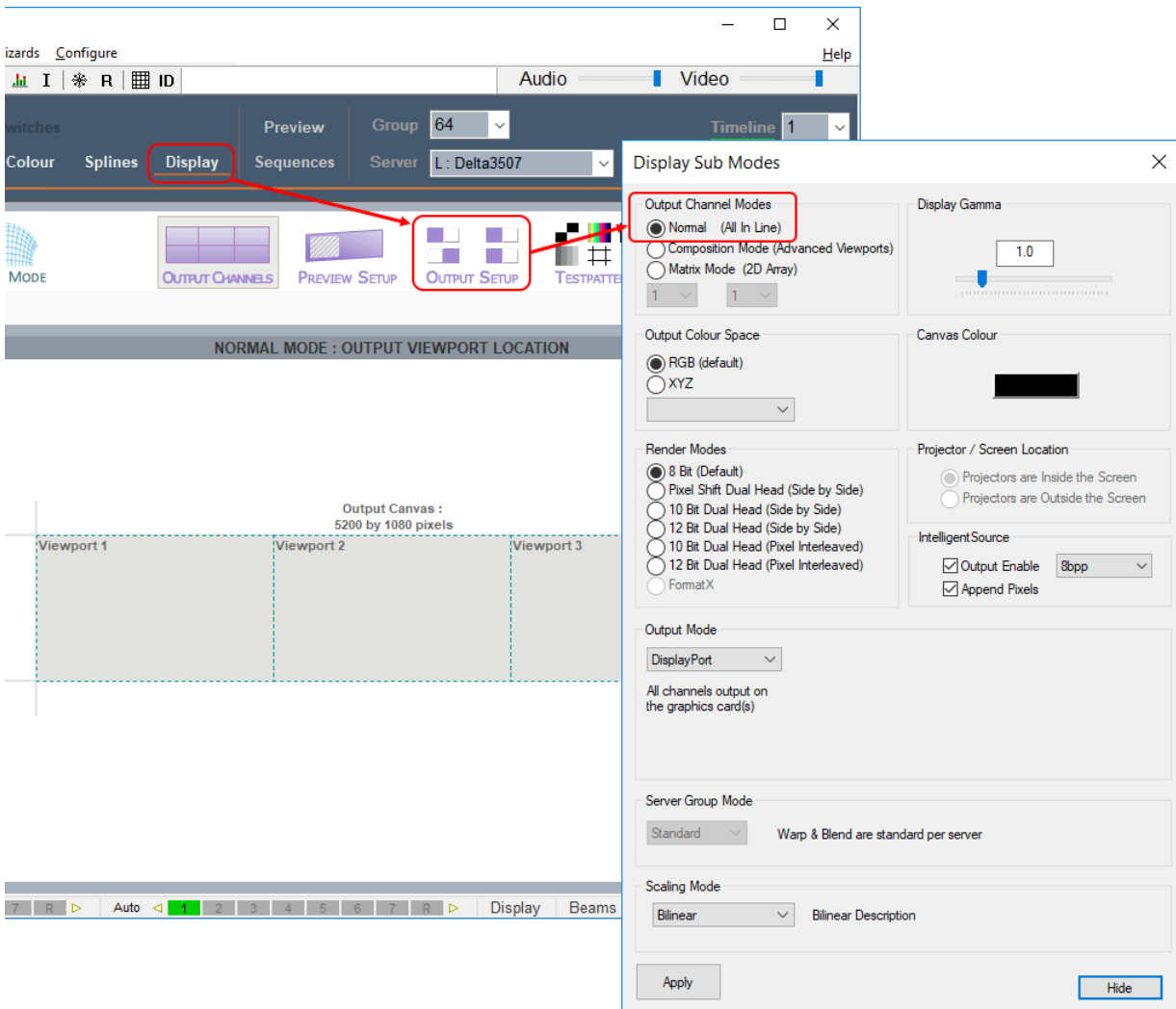

In this example, we have three  $1920 \times 1080$  channels, and have an approximate 20% overlap between channels. The wizard will rescale the canvas and provide initial warps and blends.

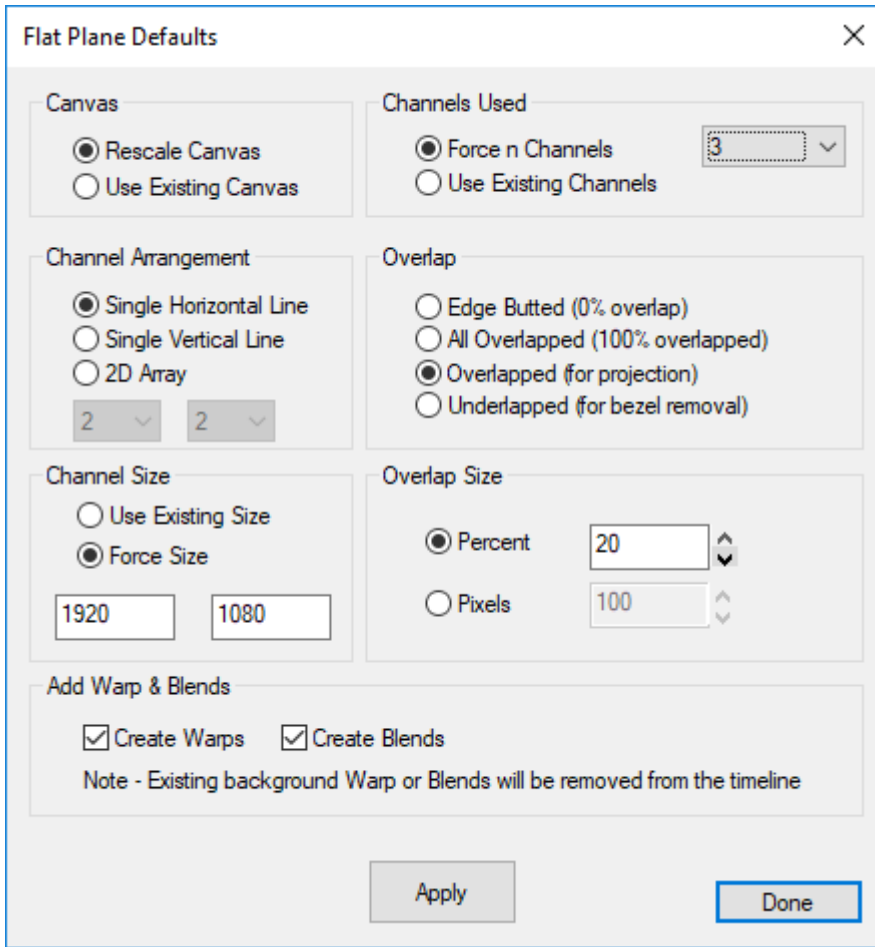

Click Apply, and Done, and you will see the three channels positioned:

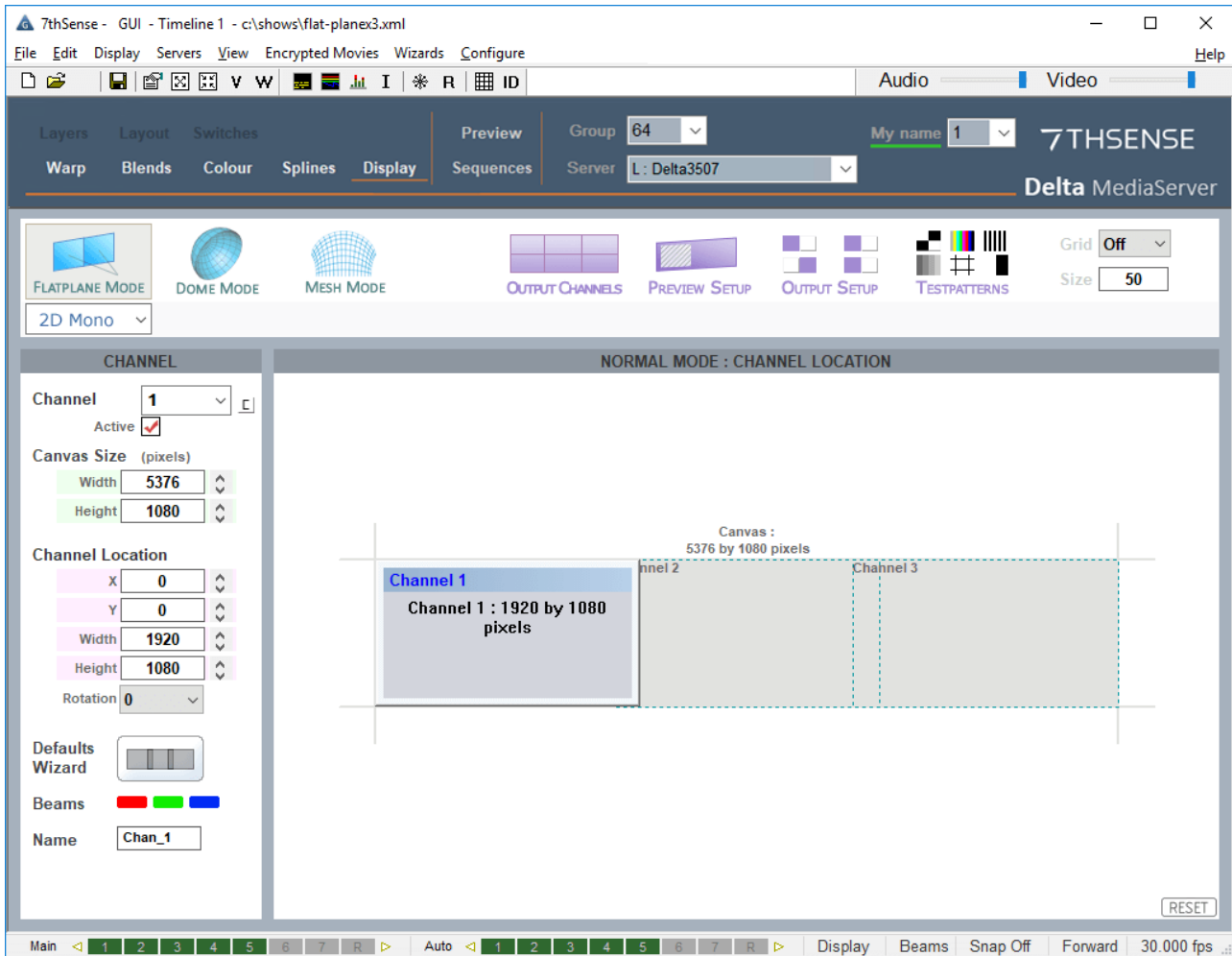

These canvas dimensions (in this example, 4992 × 1080) provide the aspect ratio for media content design.

Look at the DeltaGUI Layers view, and you will now find a default warp and blend for each channel, in the background layer, and these resources are available for selection and adjustment in Warp and Blends view.

At this point, DeltaGUI has distributed three channels to a flat, ideal canvas, but it does not know anything about the actual physical setup, such as screen curvature or projector angles and settings. We shall now project the default Delta grid onto the screen and warp it into correct position.

## Process: Warping to the Physical Surface

Disable any media on your timeline, go to Blends and uncheck 'Enabled' so that all edges will be visible, and switch on the pixel grid:

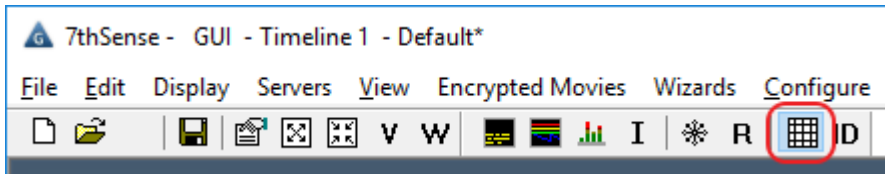

Your canvas will now show this grid, revealing not just imperfect positioning, but angular distortion and rotation, and the grid squares may be of uneven size. In this example, we are using a laser line to indicate true vertical and horizontal wherever it is useful.

Alignment is an iterative process, in which you will make minor adjustments using different tools in turn, because positioning will affect proportioning and vice versa.

### Correcting the Overlaps

Along the left and top axes of each channel you should see grid numbers. Here is a channel overlap portion with the red laser line to guide our warping. Note that the numbers should roughly coincide:

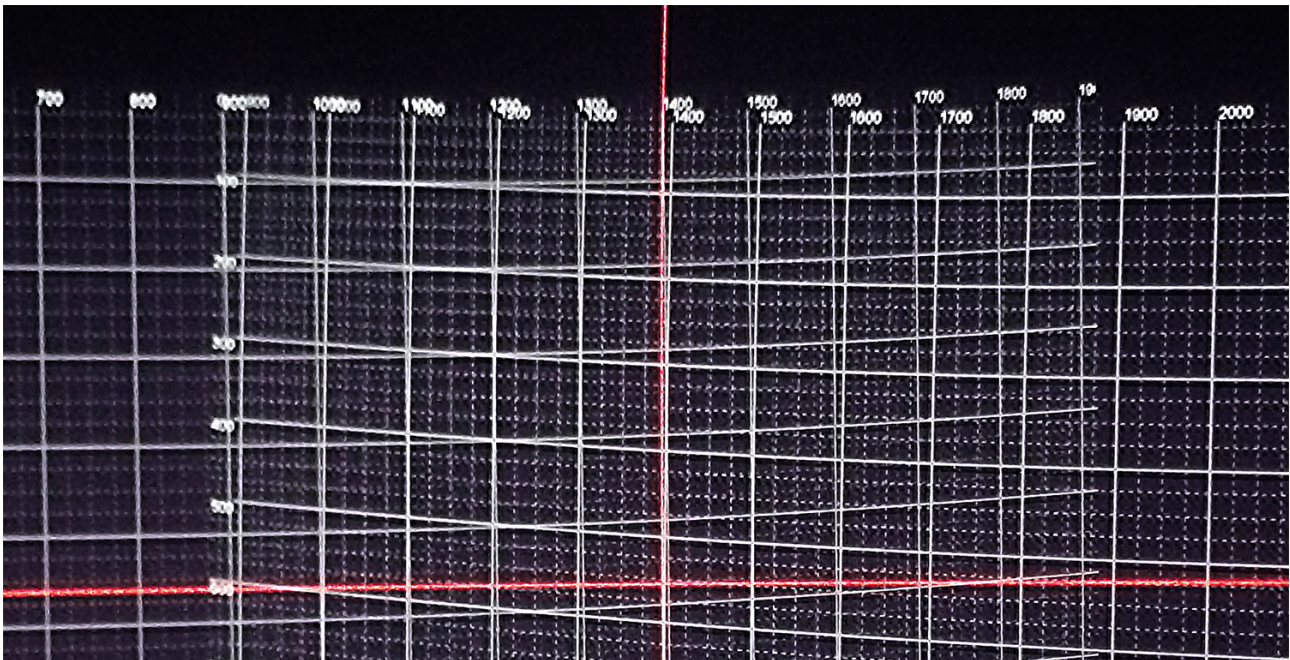

How well the numbers coincide depends on the accuracy of the overlap entered in the Defaults Wizard. You can adjust the overlap and rerun the wizard, but with multiple channels and slightly variable overlaps, you may need to adjust individual channel X and Y locations.

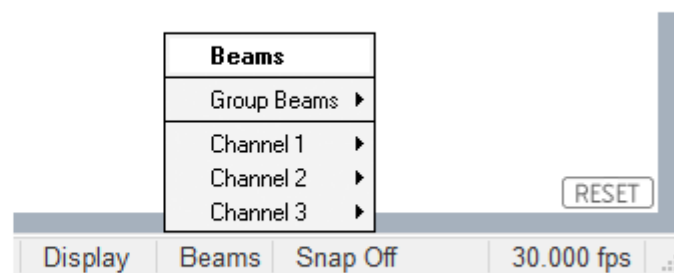
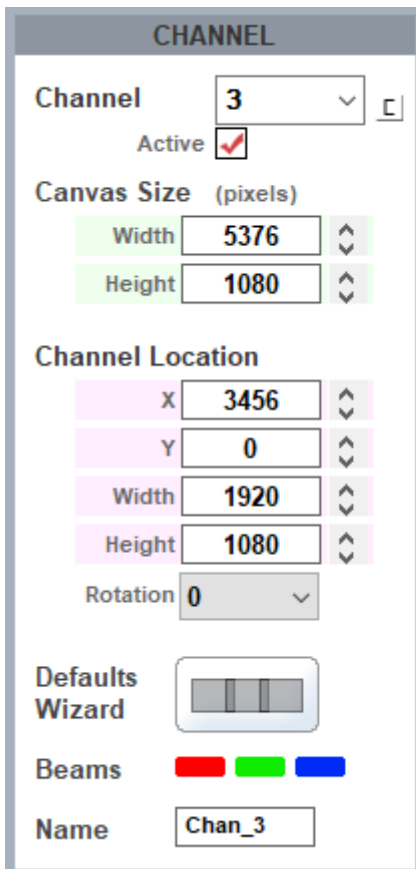

Note here too that the RGB beams can be switched out, to colour each channel differently and distinguish them. (Alternatively, use the Beams menu in the status bar.) A channel's pixel grid can be hidden by switching all beams off.

## Rotational Alignment

If a channel appears slightly rotated (off axis), Delta can correct for this. Rotation in the display setting (above) rotates the media but not the pixel grid: it is not a warp. Use this typically for 90 degree increment channel rotation.

Rotation in the Timeline warp tool rotates the grid, but within the aspect ratio of the channel. Other warps may therefore be more useful for minor realignment.

## Grid Warping

### Surface Warp

If you know the physical canvas frame positions (corners or edges) for correct aspect projection, it can help to mark these. You can then work inwards to align each channel. If the physical canvas cannot be marked, then it may be better to work outwards from the middle of each channel to straighten the grid, and to adjust for equal grid square sizing.



Focus on worst-case misalignment first, and aim for progressive improvement rather than perfection with each move.

Familiarise yourself with the warp tools and how they manipulate the grid. Learn the effects of single and multiple point selection, the difference between linear and spline (surface mode) grid deformation, and the geometric advantages of timeline warping. The sequence in which you apply warp tools can make a difference. There is no fixed way, because a faceted canvas, a single flat plane and a curve, will all require different treatments.

➤ See [Display Configuration: Warp](#)<sup>142</sup>.

Now go to the Warp view and select Surface geometry. There are two approaches.

### Outside-In Approach

If you know where the corners of a channel should be, reduce the grid to its outer points only (use the H- and V- buttons). Here the top left corner is selected for the channel 1 warp geometry, to be dragged visually into position on the physical canvas. Move a point with Ctrl+arrows, and Ctrl+Shift+arrows for fine movement.

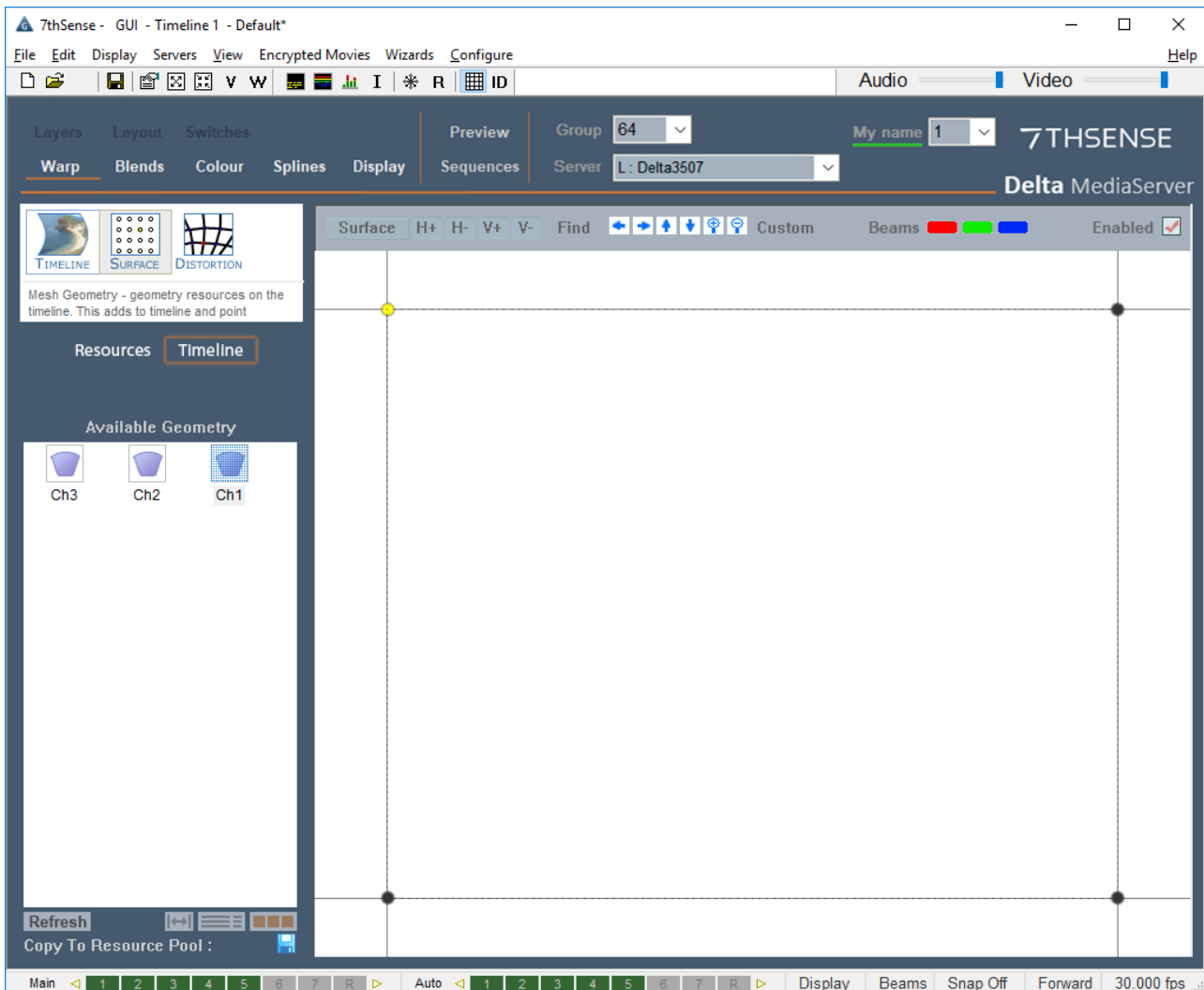

Once the corners are positioned, add grid points (H+ and V+) (adds vertical and horizontal grid lines). This enables smooth shaping of the channel to the canvas. Adjust outer borders first, and then linearity across and down the canvas (again, a laser line will help if you have true verticals and/or horizontals). Where the canvas is accessible, simple physical references, such as a measuring tape or marked card, can be used to compare actual pixel grid dimensions across the physical canvas.

### Inside-Out Approach

If the projected area border is simply relative to the centre of the media, working from the middle outwards may be more practicable. Using laser lines, more points on the surface warp grid can be used, and groups of points moved together, in order to achieve true verticals and horizontals in the grid, and linearity.

### Timeline Warp

For surfaces that are evenly flat or curved, applying Timeline geometry is quicker (these are mathematical approaches to the whole channel that include sizing, skewing, bowing and proportional linearity for all, half, and quadrants of a channel).

## Point Distortion

For surfaces with irregularities, the Point Distortion option provides a useful addition. Media with finer detail, including writing or subtitles, can become blurred, especially in overlaps, where the surface is not smooth or flat. These point, or point group, distortions are added to the other warps and are used last.

Repeat with each channel across the canvas, and adjust the channels so their grids exactly overlap those of their neighbours.

## Process: Blending Flat Plane Channels

---

Where channels overlap, the FlatPlane Defaults Wizard will have placed blends in the background layer for you. For overlapped in-line channels, the top and bottom, and canvas left and right edges will not have been proportioned, but they will need moving out of scope.

If you have not used the Defaults Wizard, and placed your own blends in the background layer, you will just have a little more to do.

Enable or disable all blends (all channels), or just the softness, using the two upper checkboxes.

➤ For full details on blending tools, see [Display Configuration: Blending](#)<sup>150</sup>.

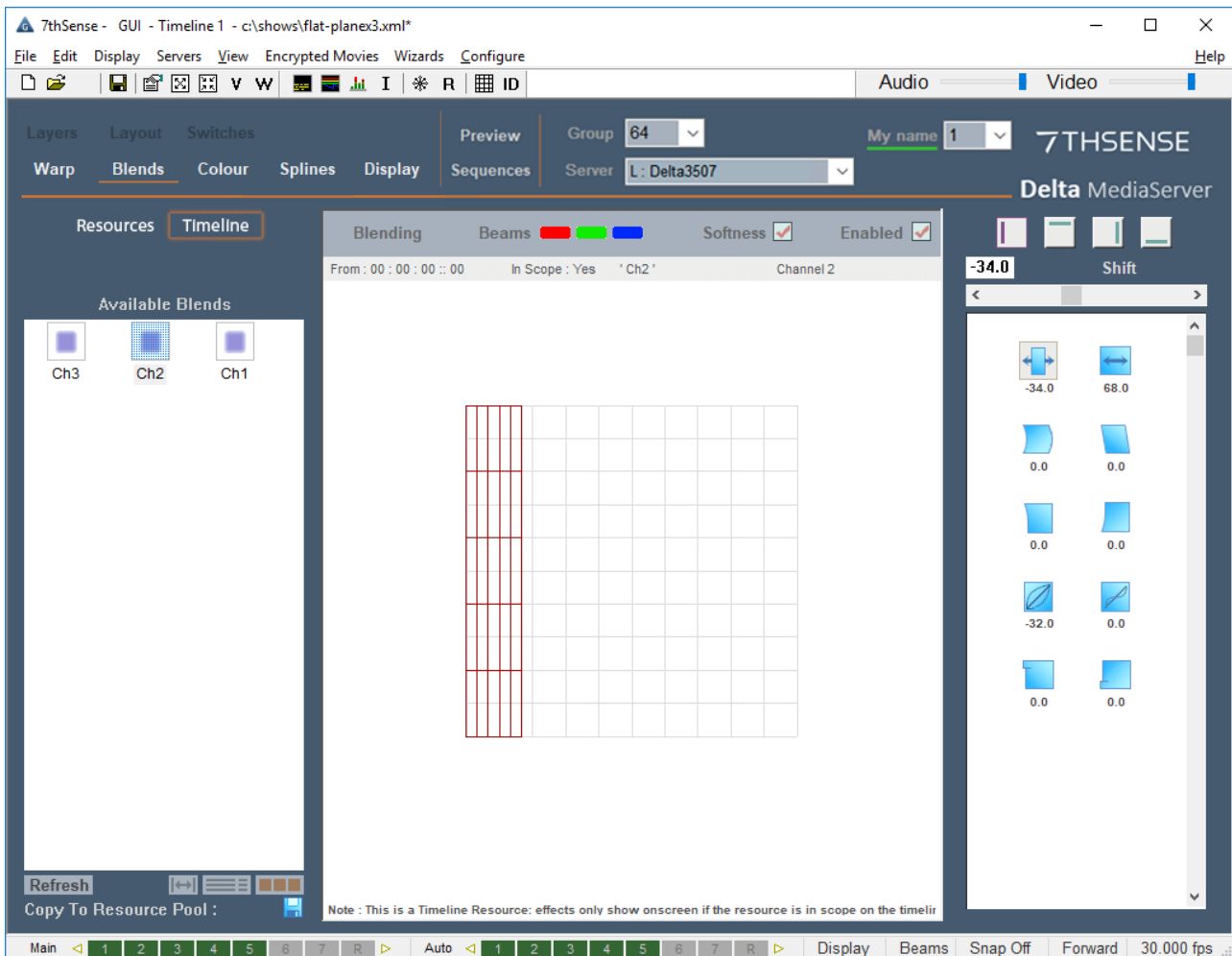

Add (or enable) timeline media resource(s) and switch off the pixel grid. If you have correctly aligned your channels, the overall display will not be torn or duplicated, but where channels overlap, the default blends may be creating shadows. Edit the position or shape, softness and gamma of adjacent blends until luminance is even. For this you can use the 'Uniformity' or 'Flat White' test pattern. It can also help to use flat red, green and blue images in turn. Finally, view your show media.

If necessary, apply a flat colour to your background layer for any channel that requires colour correction. This will complete your alignment and blending.

➤ See [Display Configuration: Colour Balancing and Convergence](#) <sup>153</sup>.

## Process: Display Configuration Files

Now you have achieved your flat plane alignment, it can be saved and applied to (merged with) any media show:

1. *File > Save As > Display Files (\*.XDL)* (do not use the Default File option)
2. *Config > Startup & File Load, Merge Permanent Display Config* (on any file load) and browse to the .XDL file you saved.

3. As and when the display configuration needs adjusting, *File > Open* and select the .XDL file to edit.
  - See [Display Configuration Files \(XDL files\)](#)<sup>(159)</sup> for more detail.

## Using AutoAlign with Pre-warped Media

Delta geometry (warp) and autoalignment functionality is normally used to fit media to a given flat or curved screen. The media is produced in a flat, rectangular format as standard, and Delta applies the required warp to any media sent to the projector(s).

If content creators and AV integrators know the display size and geometry, and the projection configuration, they may calculate the theoretical shape required and create pre-warped media to fit. The method, however, relies on projectors and lenses being setup and positioned perfectly, as well as the 'theoretical shape' of the media accurately matching the actual display, so there will always be some minor adjustment necessary, and autoalignment may be the best answer.

Since autoalignment software generally assumes flat and unwarped media, it is necessary to apply an inverse of the pre-warp to the warp calculated by the auto alignment system.

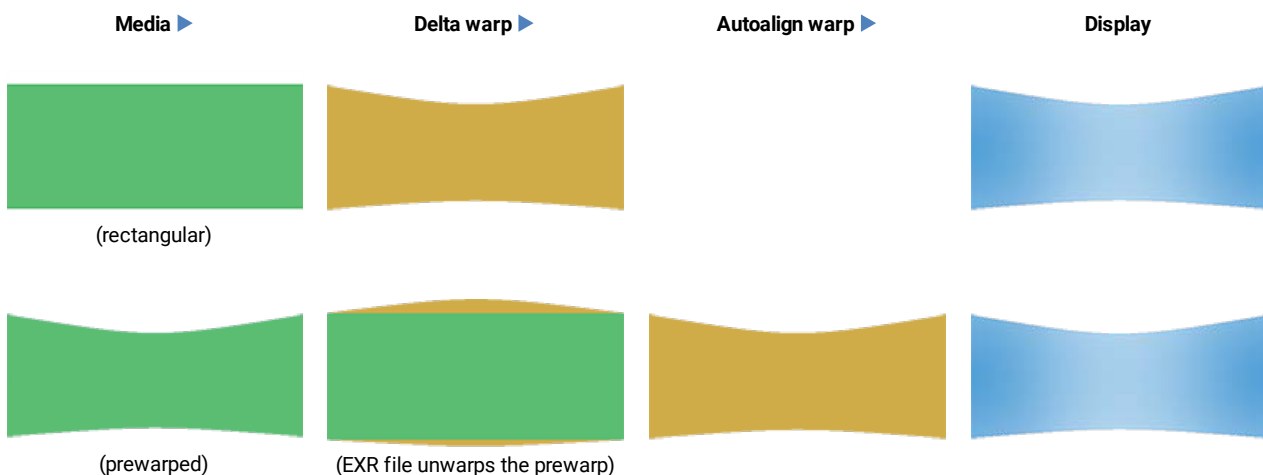

7thSense therefore requires pre-warped media to be delivered alongside the following configuration details and media files:

1. An inverse warp map for each projector in the system. To be delivered as .EXR files due to the requirement for uncompressed floating point pixel positioning of the data inside the files. The EXR files act as an ST Map (UV per pixel map) that define where every 2D output pixel location is taken from, in 2D input pixel space – in the plane of the projector's imaging device.

Red X position 0 being left, 1.0 being right of input image

Green Y position 0 being top, 1.0 being bottom of input Image

## 2. The Frustum definition and location of each projector (tan theta lens assumed)

- X,Y,Z position
- Orientation as XAxis (Heading), YAxis (Pitch) and ZAxis (Roll) rotation
- Left, Right, Top, Bottom angular width of projection cone in degrees from projectors orientation angle. This can also be supplied as a H & V FOV.

Once created, the EXR files should be stored in the C:\Geometry folder of the Delta server (refresh GUI to see in the Resources panel). Each can then be dropped onto the timeline and allocated to its channel.

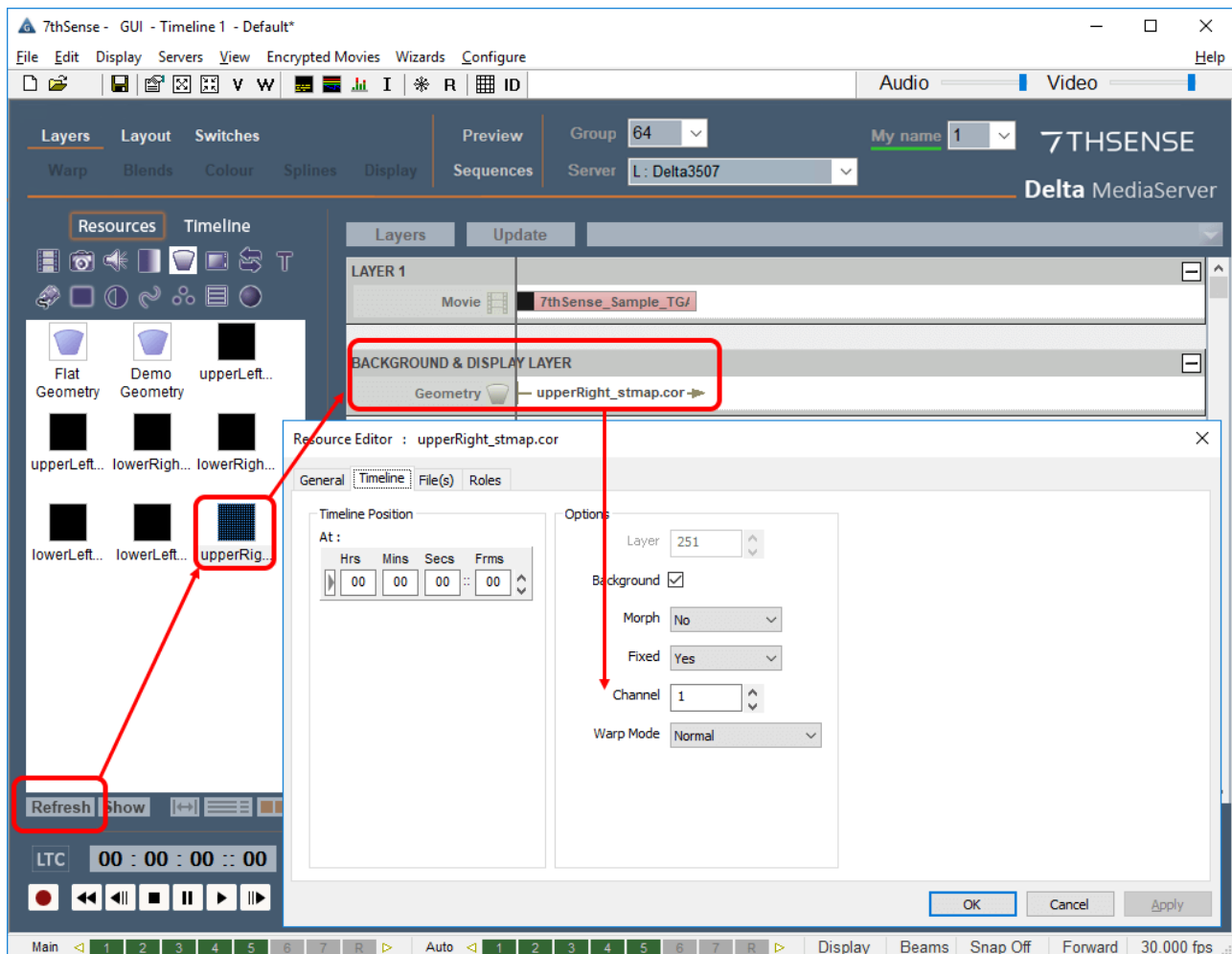

Once each channel has its EXR file attached, camera calibration (auto alignment software) can then be used for perfect alignment to the display object.

**Note:** The Projector location and Frustum positions must be fixed in the autoalignment software to match those used when generating the pre-warped media.

To ensure the highest image quality, the Delta media server warp result that is applied is only the difference between the pre-warp definition and the calculated warp of the auto-alignment system.

## Display Configuration: Composition Mode

---

Composition Mode is a Delta Licence option for managing multiple flat screens that do not form a contiguous geometric shape. This may be a complex video wall, or large-scale LED modular panels, distributed on a building or buildings, or LED backdrops to entertainment. Essentially, it is a means of placing separate output channels independently within an overall canvas.

### The principle: placing parts of a media frame into distributed channels

Media is usually designed for the shape and dimensions of the display canvas: a fisheye for a dome, panoramic for wide screen, rectangular and so on. Each channel (projector or display panel) addresses one part of the total canvas with just that part of the total media frame. This situation can be optimised for bandwidth or processing capacity by carving the media down to only the part of each media frame required for each channel, but the parts remain channel-mapped and the channels all fit together with overlap and blend.

However, in the case of distributed LED panels that do not form a contiguous geometric canvas, the media design can itself be pre-optimised, and the separate rectangles packed far more economically into a frame that minimises empty pixels. Take this simple example where an arrangement of display panels is used to display a single piece of media:

The media could be rectangular:



Even though the LED display array is not:



But that is far from optimal. So taking only the media area (viewport) required by each display panel channel, the elements can be packed tightly:

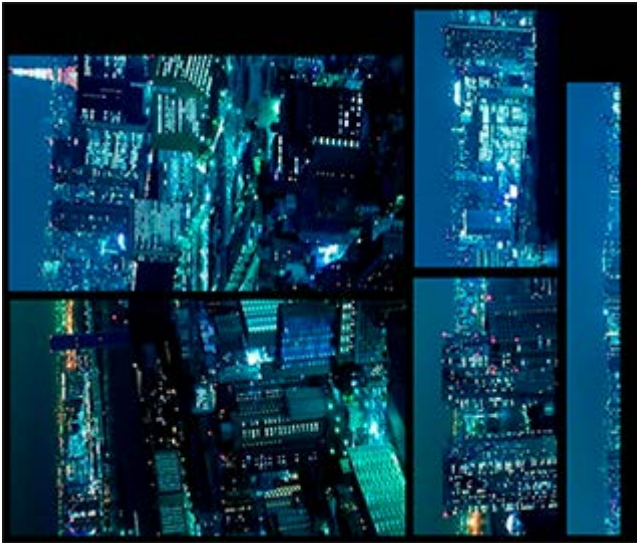

Using mapped co-ordinates, Delta composition mode extracts each element of the media, rotates and/or positions it to address each channel (LED panel) appropriately:



## Multiple Distributed Displays

In other cases, different media might be addressed to the various channels in a more complex or really big array. Compare the real array (left) with its logical layout (right):



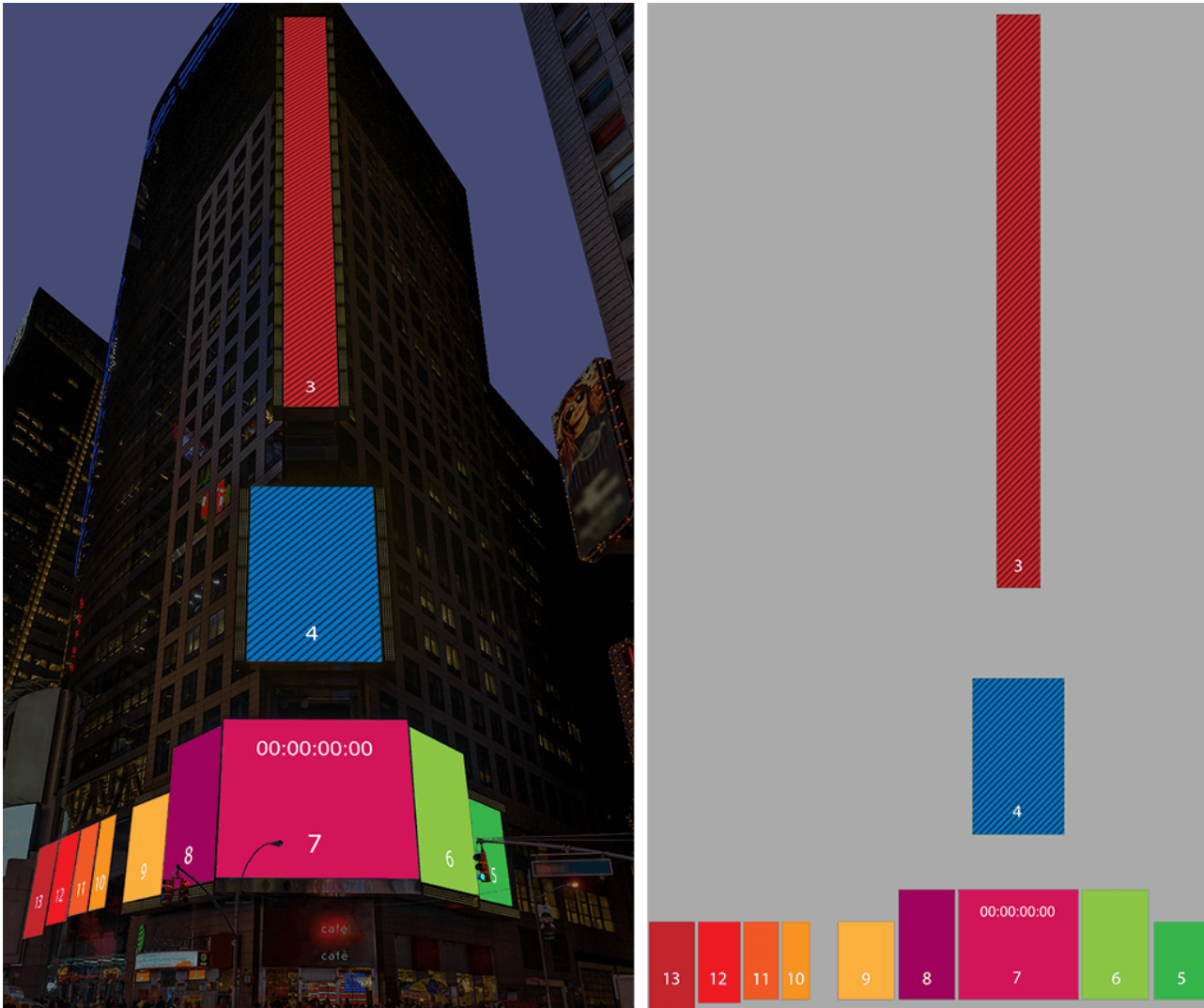

Again, there is a lot of unused area, when treated as a whole, which wastes a lot of bandwidth. The media can be sliced and packed more efficiently in the frame; we then unpack it on the Delta canvas. Note how a single LED display (the long thin one) can itself be sliced. Pieces can also be rotated in the packed file, and rotated back on the Delta canvas. Here is the packed frame:

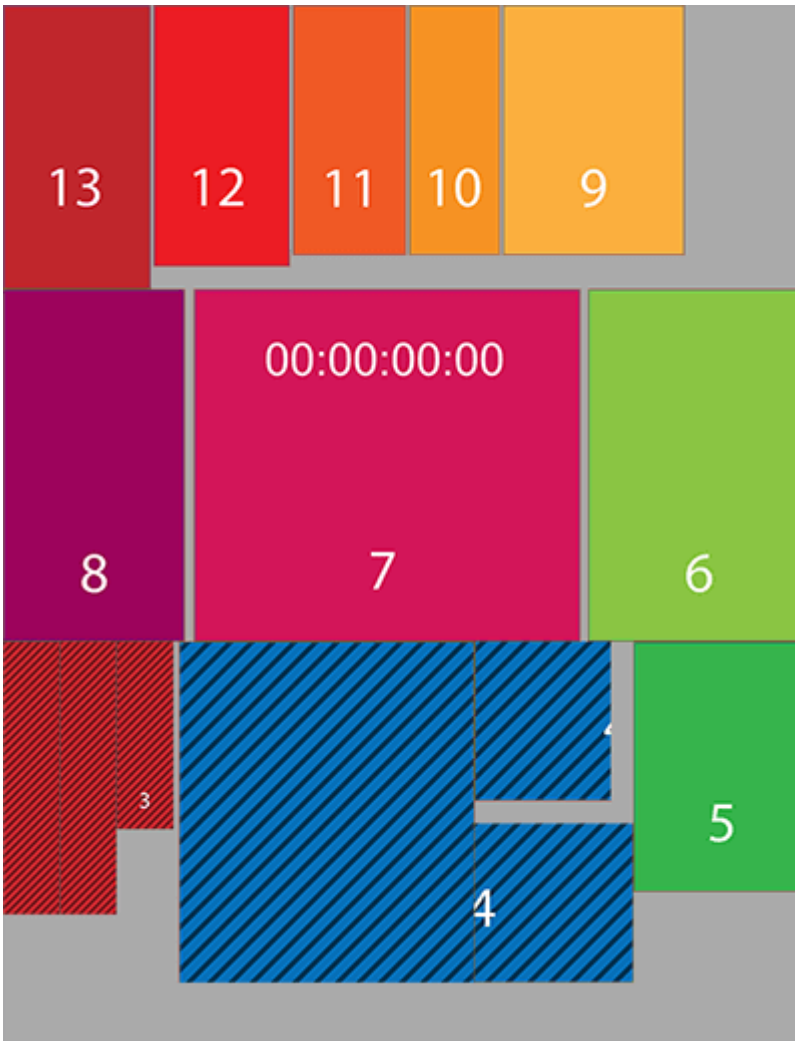

**Output Blocks**

The size of the media frame is dramatically reduced, but an LED processor is still limited to what it can process (often up to HD 1920 × 1080 pixels) and so this format may still be too big for an individual processor.

To break the media up further, the *unpacked* media can be planned on a Delta canvas of 4 × 1920 × 1080 HD blocks:



All we need to do now is to find the coordinates and dimensions of each LED panel in the packed artwork, make each a channel, and then place the viewport for each channel in the output, according to this plan.

Delta will place the elements in the output, and the LED processor will be programmed to map the outputs onto the displays.

**Important Note:**

Prior to creating your show in Delta, you must prepare your media (as above) and ensure that you calculate the size and position of each LED output screen in relation to a rectangular canvas:

- Note your canvas size in terms of required outputs (total height × total width in pixels).
- Establish the coordinates of the LED display elements within the media.
- Draw up a diagram to show position and size of each viewport within the canvas.

## Composition Mode in DeltaGUI

In DeltaGUI, set the [Output Setup](#)<sup>128</sup> to Composition Mode.

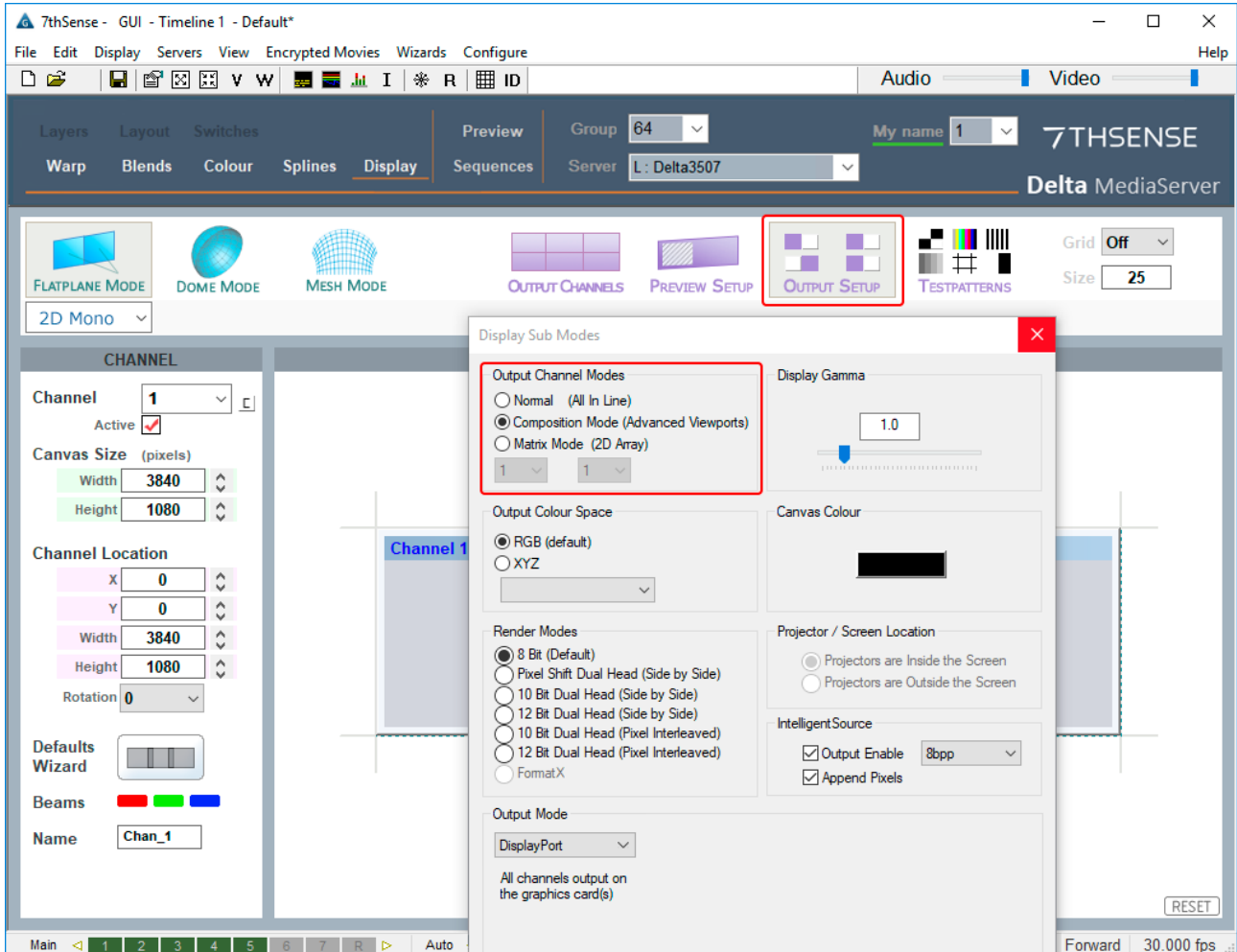

## Set up Channels and Canvas Size

It is recommended to set one channel per viewport (LED screen). Click the **C** button to activate a channel for each LED display:

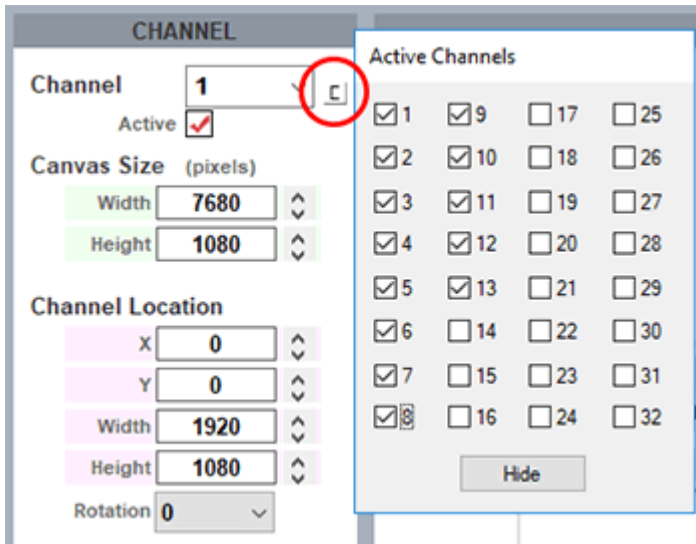

Enter the Width and Height of the total canvas (to match the total media pixels, here 4 × HD outputs), then selecting each channel (LED display) in turn, enter its width and height, and XY location. Whilst channels can be dragged to position in this view, you must know the numbers and will have to enter these anyway. You may find it easier to activate, locate and place each channel in turn. These illustrations show the finished result.

Note here how all the channels have been located, and now look the same as the packed artwork. Channel 7 is selected, showing its position in the media frame, and dimensions. If a display has been rotated in the media to better fit, correct the rotation here.

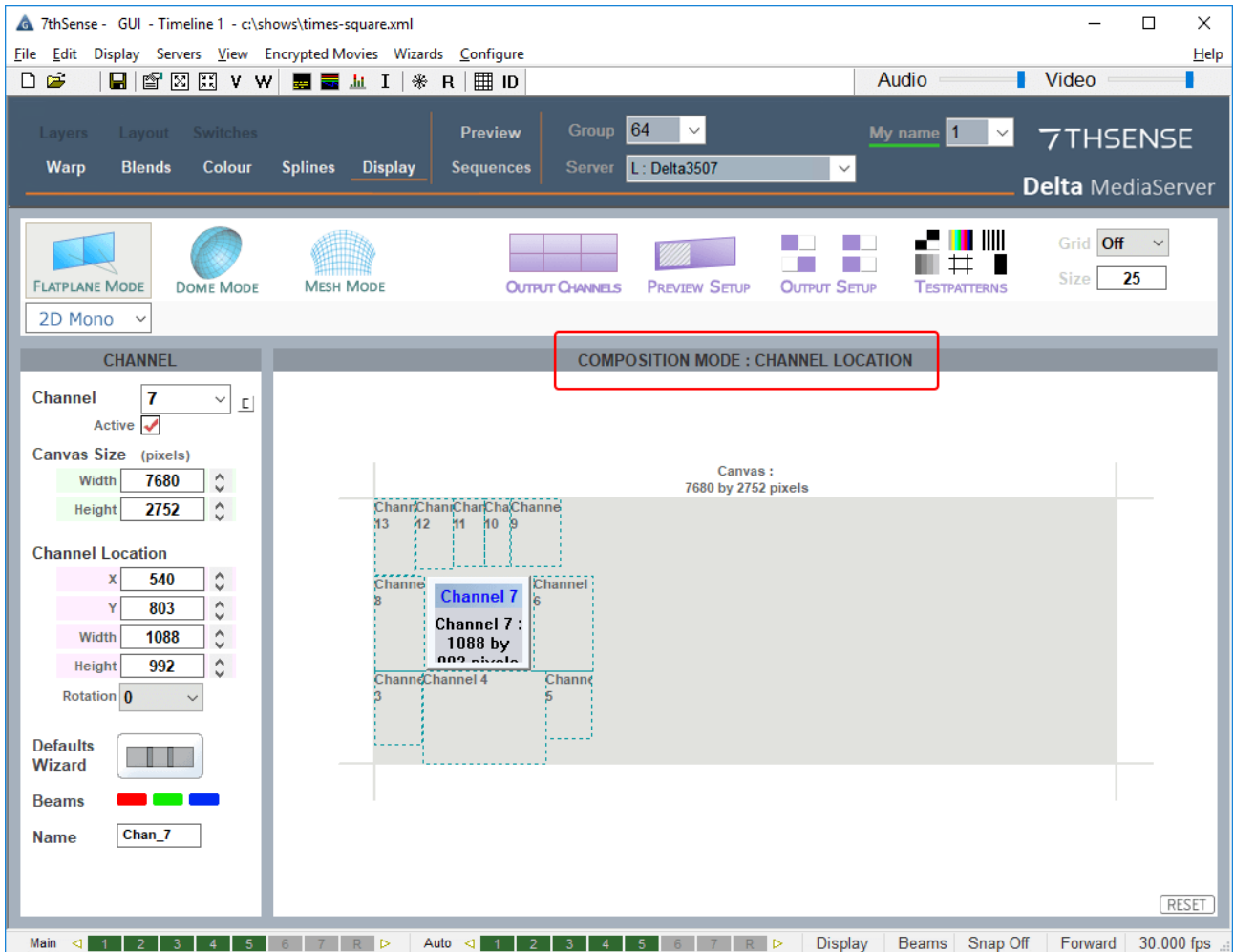

Next position this channel (area of the packed media) on the output.

Click 'Output Channels'. Width and height will be the same as for the channel, the Viewport Location will be as shown in the HD output blocks (see above).

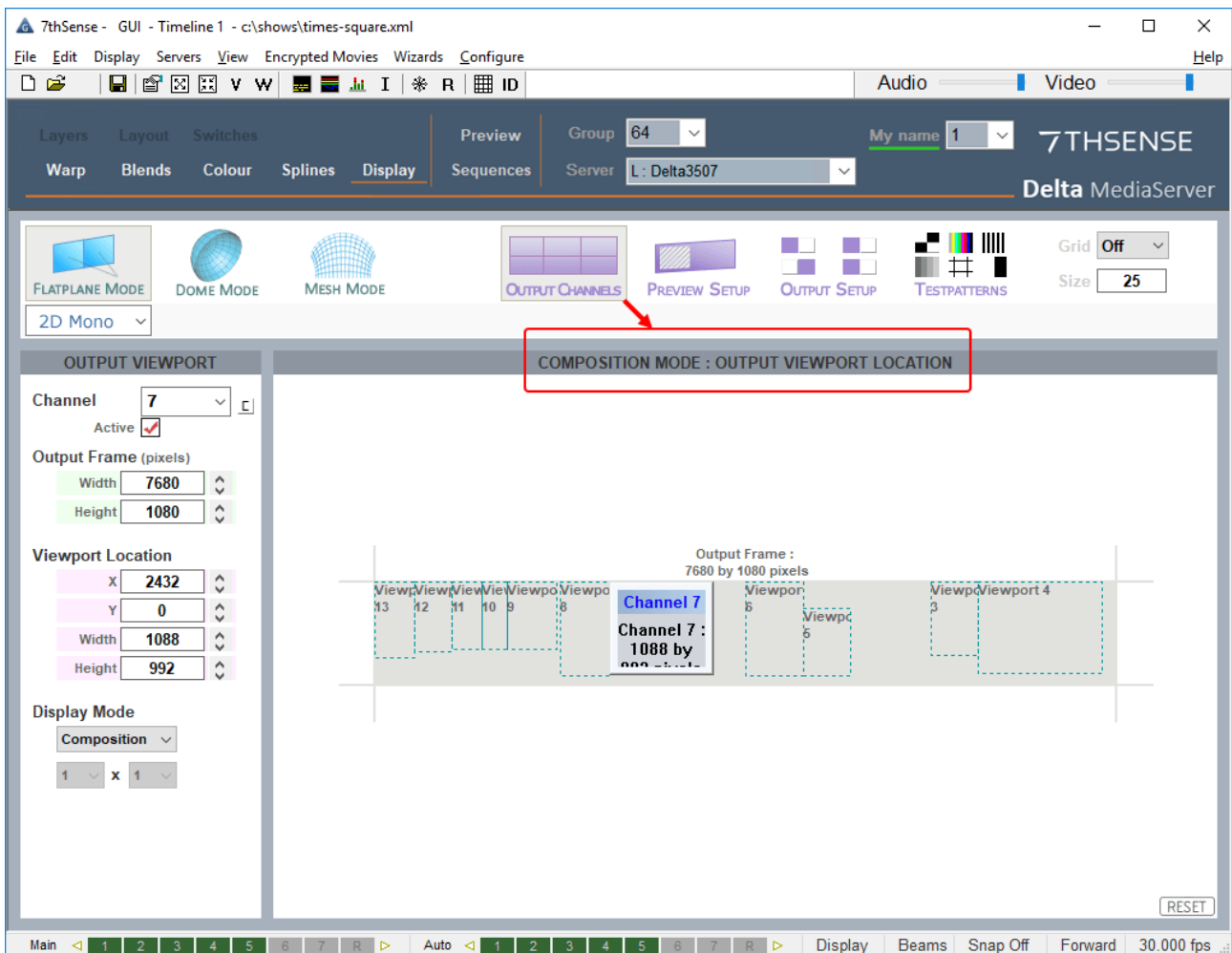

This completes the composition; the rest is up to the LED processor to render the outputs to the display panels. (The Delta Playback window will not make much sense in this mode.)

## Composition Mode and IntelligentSource

To enable all outputs in Composition Mode to carry the IntelligentSource data row, a small adjustment must be made.

With IntelligentSource data stream enabled, you will see the data row visible as the top pixel row in the Playback Window. In Composition Mode, you will initially only see this in the first (top left) output, so you must restore it to every output.

In *Display > Output Setup*, make sure that you remain in Composition Mode and that using the drop-down boxes beneath 'Matrix Mode', you represent the same output arrangement as your graphics driver (e.g. NVIDIA Mosaic).

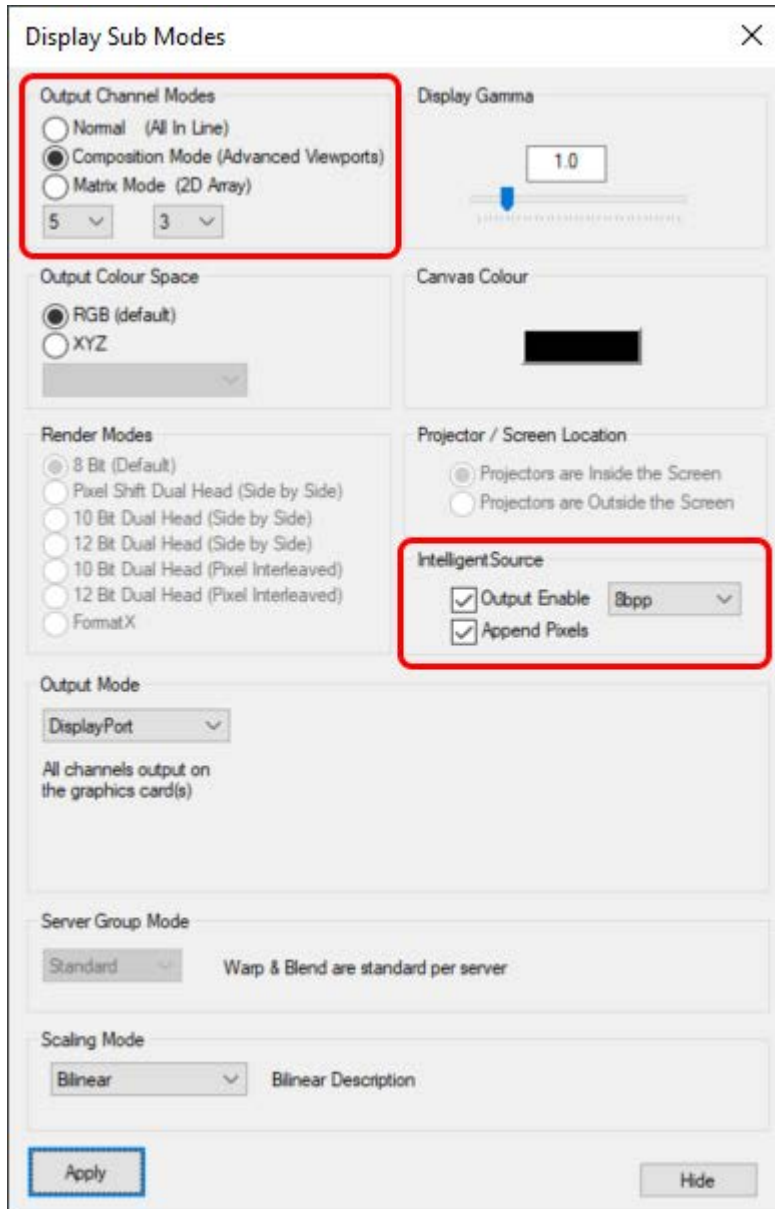

You will now see the IntelligentSource data row flickering in the top of each output in the Playback Window.



## Display Configuration: Dome Mode



Dome or frustum mode is a Delta licence option, for projection onto spherical or ellipsoid surfaces.

For projection purposes, measurements are relative to the eye-point. For a hemisphere, this will be the geometric focal point; for a partial hemisphere (illustrated here), it will be at the centre of the intersecting plane. Elevation is taken from the eye-point, with  $90^\circ$  being vertical to the dome centre,  $0^\circ$  being from the eye-point to the dome edge. Azimuth, or horizontal sweep from the eye-point reaches from  $-180^\circ$  left to  $+180^\circ$  right. Linear measurements are in mm.

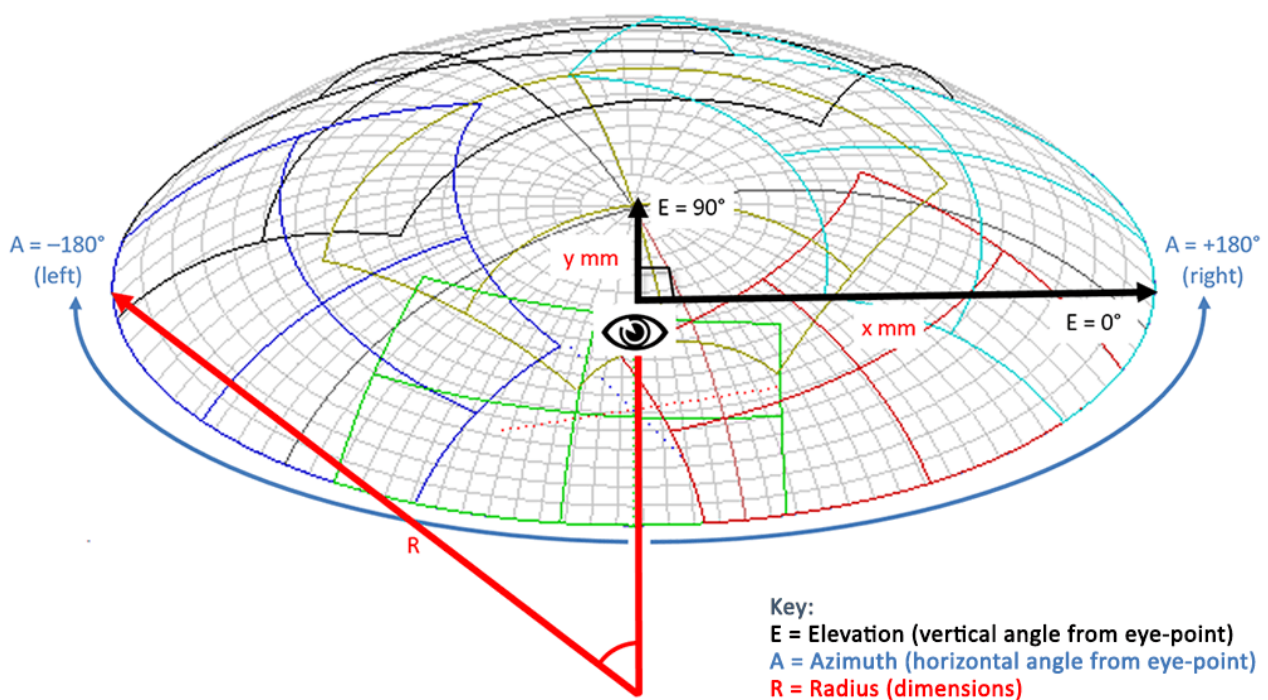

In Dome Mode, media can be placed on the canvas as flat, fisheye, panoramic or channel-mapped, as required. The projection area of each channel is outlined in a different colour in the DeltaGUI representation.

### Defining the Canvas

Screen shapes can be spherical or ellipsoid and are assumed to be geometrically accurate:

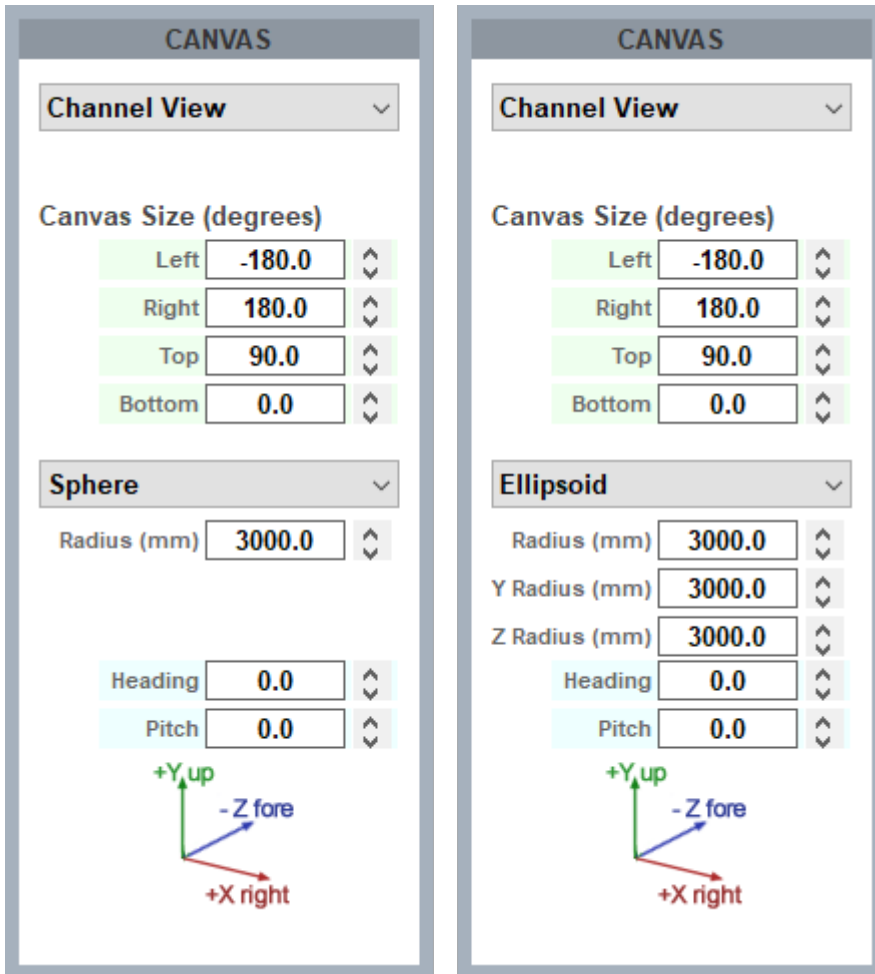

## Alignment, Warping and Blending

In the real world, projectors cannot be fixed accurately or ideally, and any movement will result in misalignment. Autoalignment software (7thSense recommends Scalable Display Manager) can be used on a regular basis to keep the display correct. Between the Delta defaults Wizard, manual adjustments and autoalignment data, you can very easily achieve optimal channel overlap, to which you can add warping (if necessary) and edge blending. By the nature of domes, you must ensure sufficient overlap at the dome edge, where this is smallest (8 degrees is advisable).

- See: [Configuring Delta to use Autoalignment Data](#) <sup>(208)</sup>

## Dome Mode Views

### Channel View

Channel View shows the segment of dome surface covered by (as 'seen' by) a single channel:

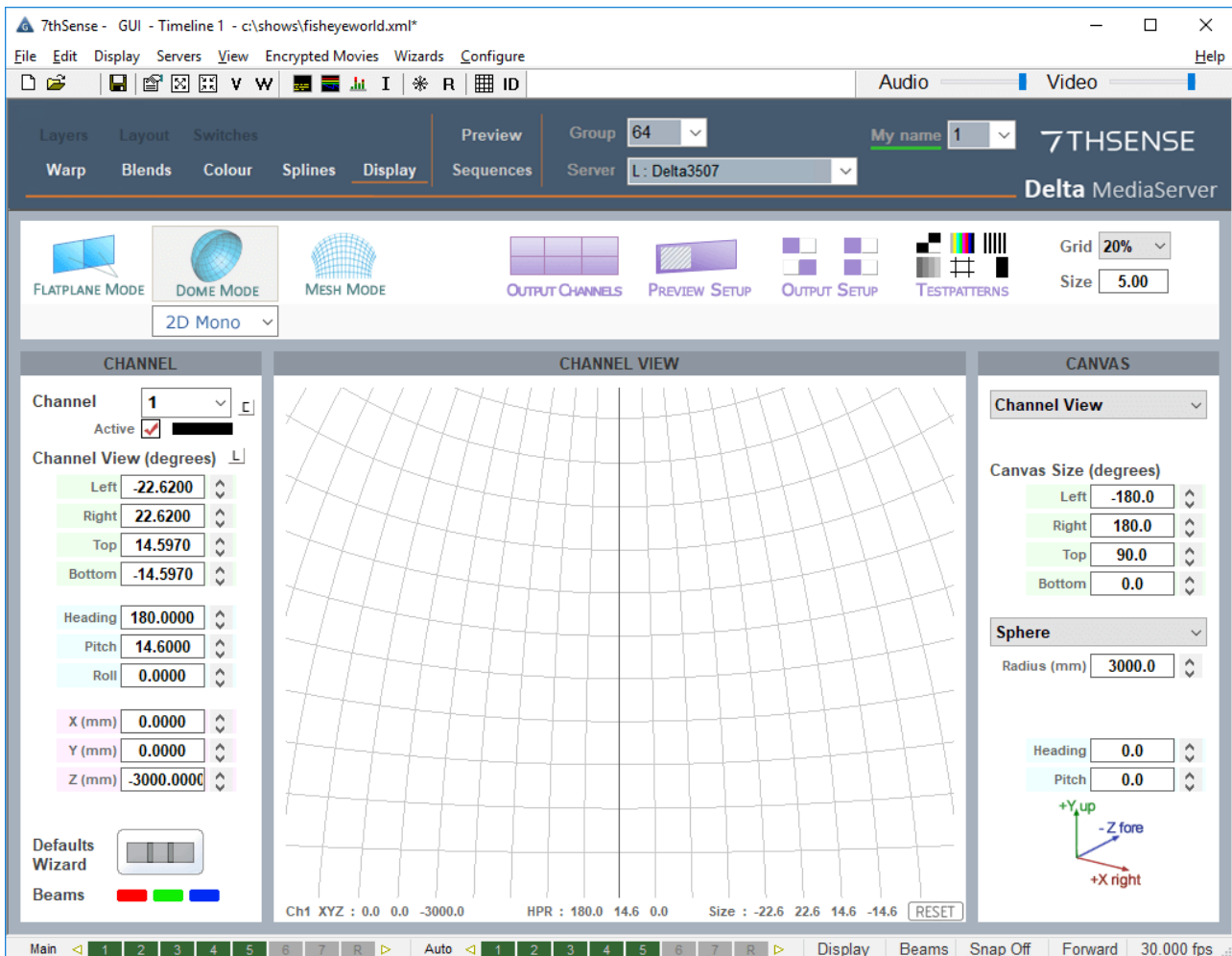

Note that the channel dimensions are reflected in the bottom status bar of the view. The **RESET** button restores channel dimension defaults.

### Interactive view

It's best to view the dome in Interactive mode, moving the interactive view to be from beneath the dome, looking up to see the whole dome surface. Use the mouse controls shown, to drag the model (or click on the mouse arrows) and manipulate the view.

#### Mouse controls:

- **Left-click + drag** : pan and tilt the whole mesh

- **Right-click + drag** : shift the whole mesh
- **Centre-click + drag** : zoom
- **Shift+left + drag** : spin the mesh around a set point in 3D space

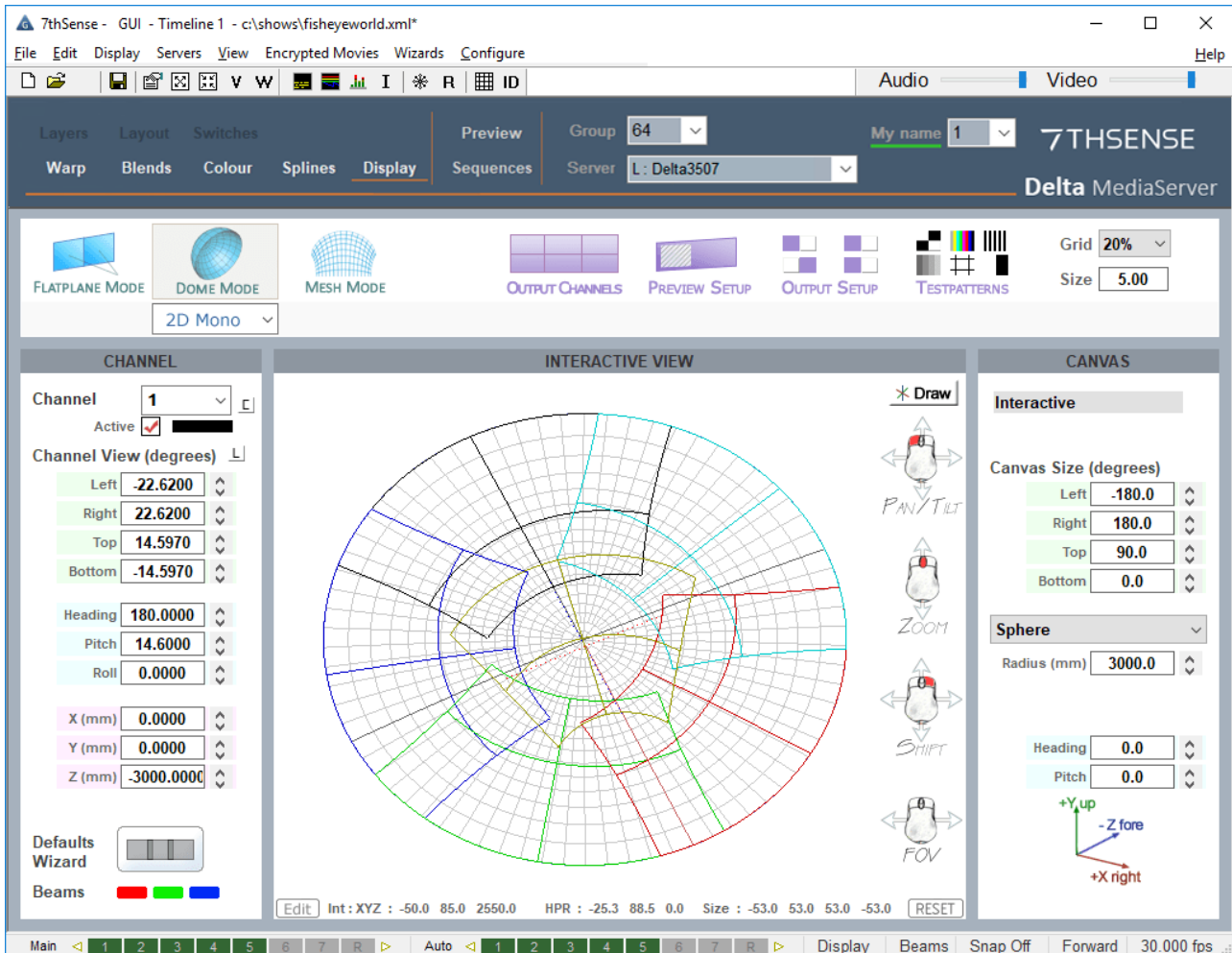

Note that the current interactive viewpoint is reflected in the bottom status bar. The **Edit** button allows you to save and name viewpoints and return to them:

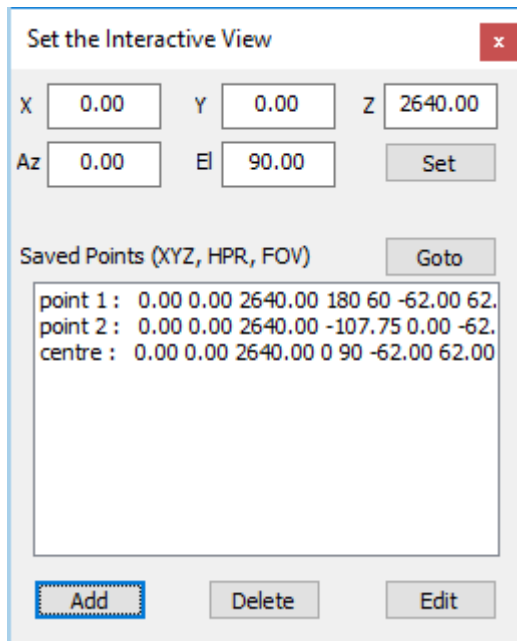

X, Y, Z, Azimuth and Elevation are from the current view, and can be further adjusted here. Field of view is saved from the current view.

If you want to see the origin of the frustum (which is the projection point location), press the \*Draw button, select *Frustum > Lines*, or select 'projectors visible', if that is helpful.

## Preview Setup and View

To view a spherical dome projection correctly requires a square format. Set this as a custom format in *Configure > Preferences > Preview Window*.

The Preview Setup button enables you to manipulate the viewpoint of the Preview window:

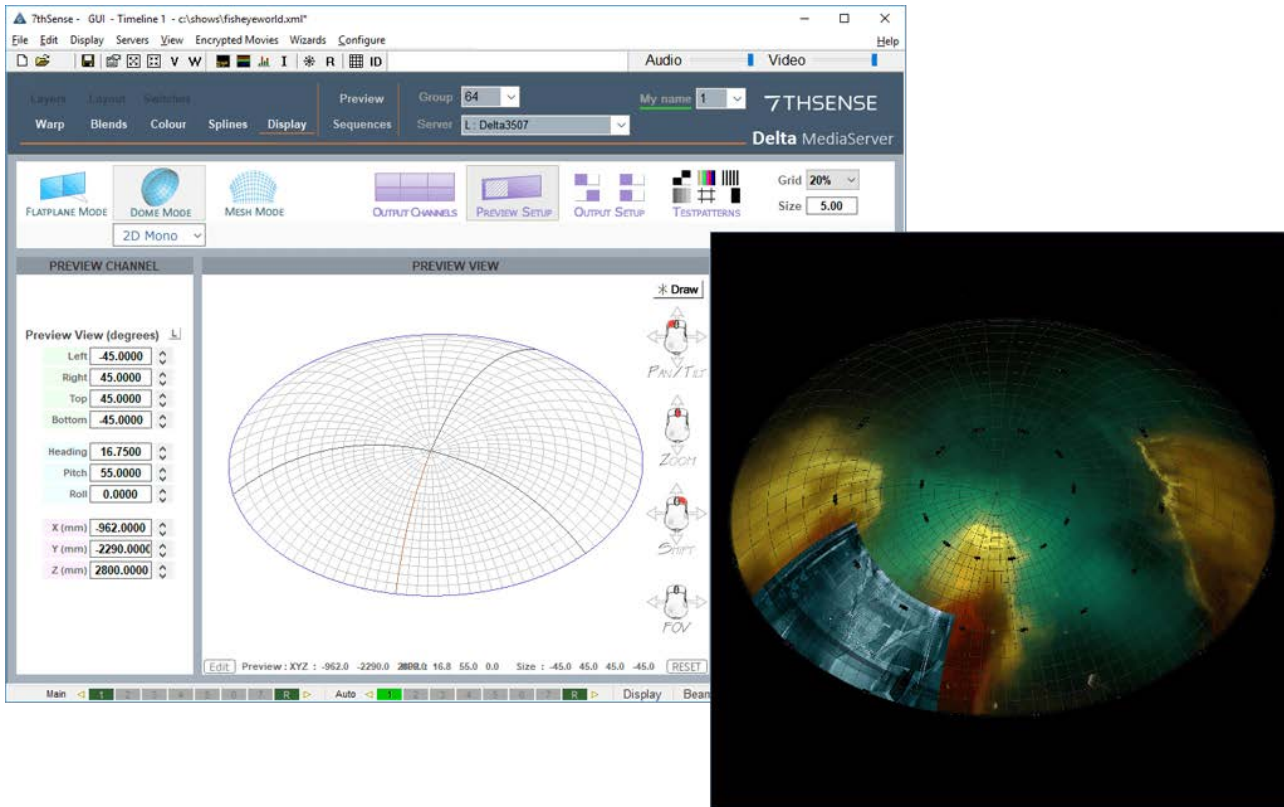

A reference grid can be overlaid on the preview and (below) playback window, selectable in degrees of separation (the number you enter is degrees between the lines) and visual intensity in percent. Enter settings where circled in red above, and toggle the grid on and off with the toolbar icon.

## Playback Window

In Channel Mode in DeltaGUI, the playback window will display the channels arranged according to how the graphics cards are configured. This will normally be each channel side by side (see Output Setup), unless the graphics card has been set up in a  $x \times y$  matrix.

In Interactive mode, the playback window will display the dome from the DeltaGUI viewpoint, and as you drag or move this in the DeltaGUI window, it will follow in the playback window. Alternatively, the playback window image itself can be dragged around with the mouse directly.

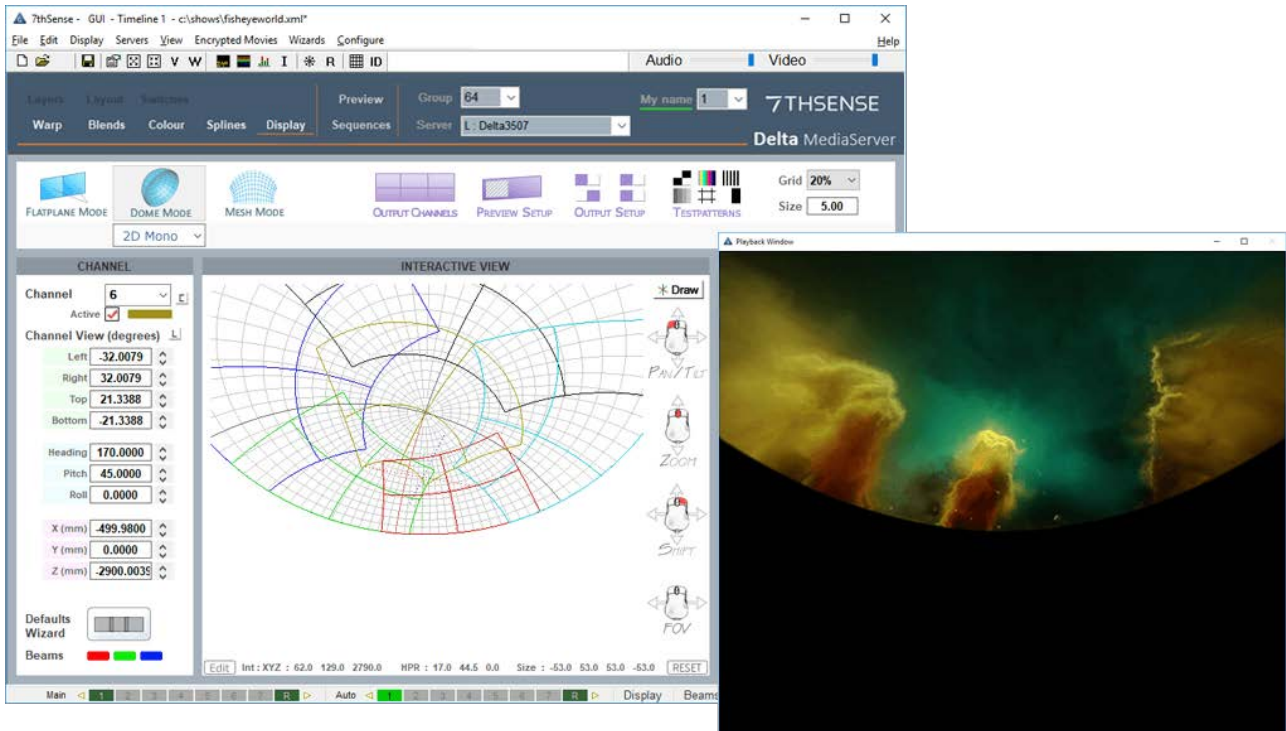

The *composite illustrations* below show the how the grid appears, when superimposed on the image, in each mode (left: channel mode, right: interactive). Blends and warps between channels are not shown in the playback window.

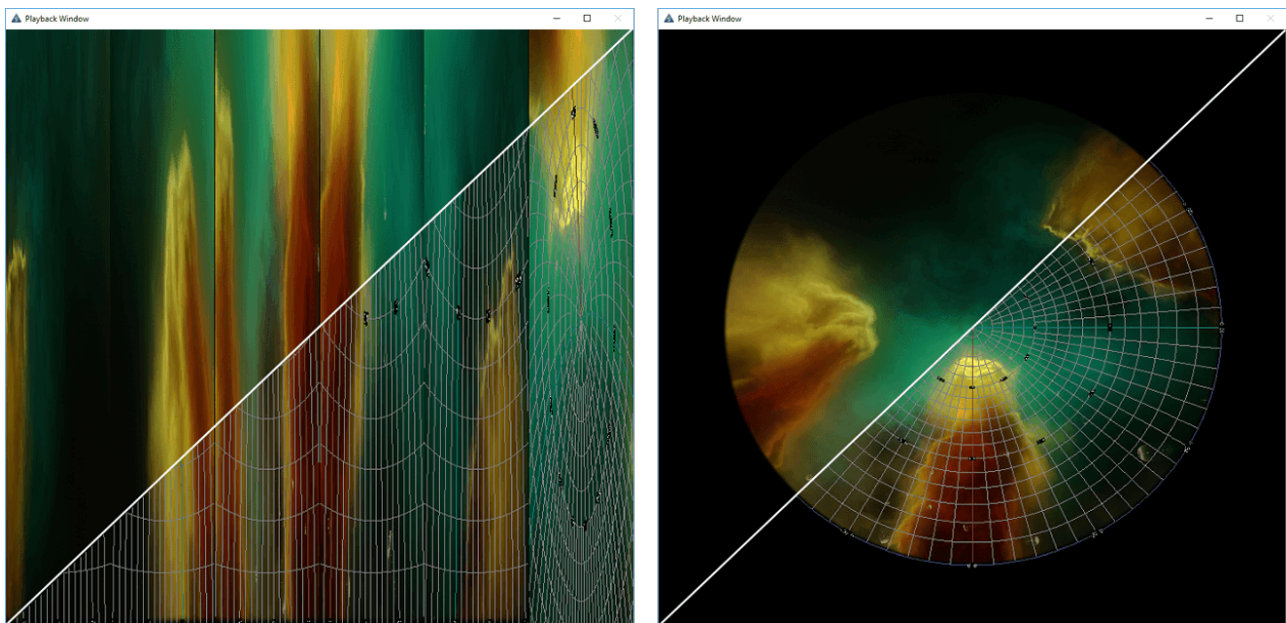

Fisheye image credit: NSC Creative: from 'We Are Stars'

## Defining and Sizing Channels

Set the number of active channels (projectors). Using either or both the default wizard and the channel dimensions settings, you will define the rectangular area of the dome covered by each channel. The centre of this area is given a (horizontal) heading, (vertical) pitch, and (rotational) roll. Its width is defined by left and right angles, and height by top and bottom angles.

Click the **C** button to define active channels. This example will be for 5 surrounding channels and a cap channel.

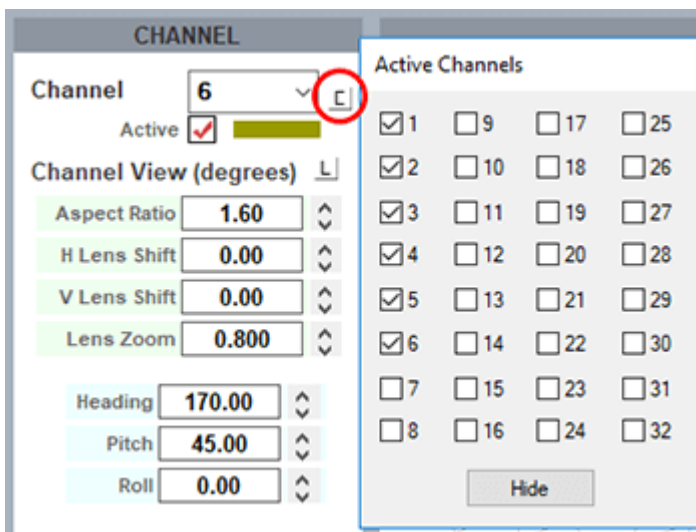



## Channel Sizing (Default Wizard)

Delta will distribute channels automatically, from where all channels can be adjusted manually. Press the Defaults Wizard button to view the configuration dialog:

The Dome Mode Defaults dialog can place projectors around the dome interactively, so you can design the projector coverage to allow sufficient overlap for blending, or note where projectors have to be placed due to lens restrictions etc.

### Force Size

choose Force Size to force the dialog's channel values into the server, or Use Existing Size to leave them unchanged.

### Aspect

Alter this to the aspect ratio of the projector's output video format, so for example,  $1920 / 1080 = 1.777$ , or  $1920 / 1200 = 1.6$

### HShift / VShift

Alter these values to match the known projector lens shift, so for example if the projector has no lens shift (image is dead center in the lens), leave these at 0, but if the projector has an inherent 100% lens offset vertically, enter 100 to VShift, 0 for HShift.

**Zoom**

This value should match the projector's lens zoom value (0.8 = wide angle, 1.2 - 1.6 = standard type zoom, 2-4 = long lens).

**Pitch**

Alter this value to pitch the projectors up to fill the dome. A typical projector arrangement is to have projectors located on the dome springline (horizon), so they need to pitch up to fill the dome.

**Roll**

Alter this value to match the projector roll angle if any, or for example set to 90 if the projector is in portrait mode.

**Channel Arrangement****Projectors at dome centre**

choose this if they are all at dome centre, facing out to the dome surface (unusual).

**Projectors at screen edge**

choose this if they are all at the screen edge, crossfiring to the dome surface (typical).

**Projectors inside screen**

choose this if they are all within the dome, crossfiring to the dome surface, you can set a separate radius from dome centre where the projectors are located.

**Projectors outside screen**

choose this if they are all outside the dome, firing on the outside of the dome surface, you can set a separate radius from dome centre where the projectors are located. Note in interactive mode on the server, content is only shown on the outside of the dome surface.

**Channels Used****Force n channels**

or leave as-is

**Include Cap**

will make the last channel point up at the dome pole, from near to where channel 1 is located, and also choose a wider Zoom for that one channel so it covers more of the cap.

**Screen**

Set Screen Radius

**Force a radius** in mm or leave as-is

**Spacing**

Set the spacing angle in degrees, or set to Calculate (default) to allow DeltaGUI to move projectors to equally spaced around the dome.

**Channel Size (manual adjustment)**

It may be necessary to make adjustments, or direct settings for a partial dome (see the example of a [panoramic dome](#)<sup>(205)</sup> section, below).

Set or adjust the dimensions for each channel or use the **L** button to use lens characteristics instead of angular dimensions:

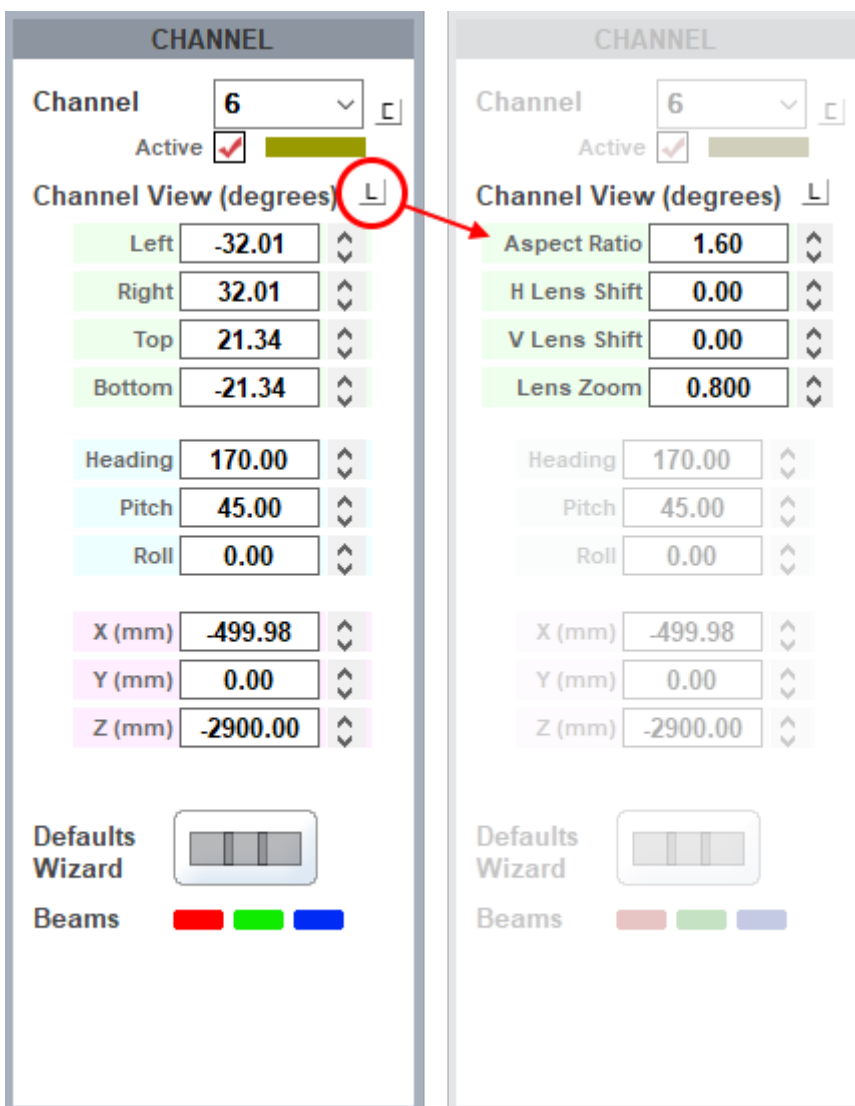

## Media Resources and Layers

Resources are layered on a dome as on any screen, including any animation, fading or transparency effects, and [transform animators](#)<sup>(350)</sup>. Note that rotating a flat resource is about its design centre and within its channel area, not about the dome centre.

*Configure > Preferences > User Interface > Features > Features* includes the option to enable [Intelligent Resources](#)<sup>(109)</sup> to detect fisheye, panoramic, flat or channel-mapped.

**Note:** Dome Mode resource defaults are set in *Configure > Preferences > Resource Defaults > Dome Mode Defaults*.

Layering resources on a dome is exactly the same as a flat screen, but different original mapping modes require different treatment. For example, here a **flat** image has been layered over a **fisheye** movie. The square image has required a geometric warp to be applied in the timeline, to re-align with the dome grid. Its position on the dome has been adjusted in the timeline Resource Editor. A channel-mapped piece of media would not require such geometric warping.

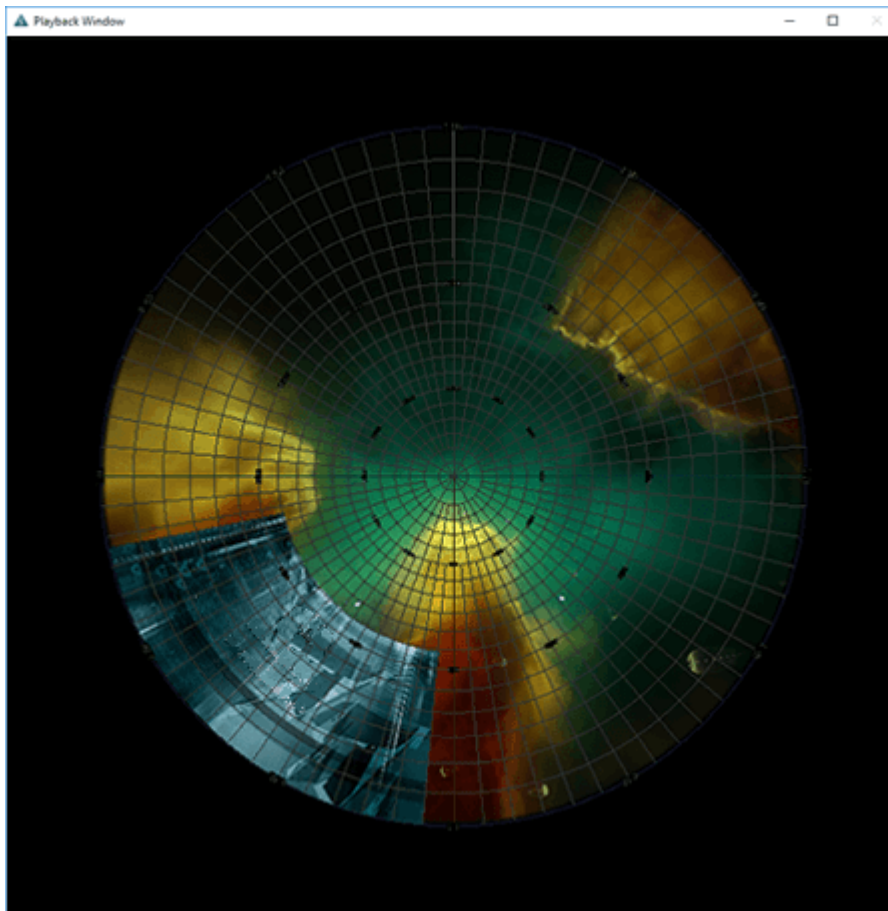

Fisheye image credit: NSC Creative: from 'We Are Stars'

## Panoramic resources

Panoramic media can be stretched around a dome or partial dome (spherical segment). Here a spherical canvas segment with three channels has been used, rather than a full dome. The canvas size and channel coverage have been entered into DeltaGUI here, and the angular height and width properties of the image entered in the timeline resource properties editor. The DeltaGUI **interactive view** shows the projectors and lines, and the grid is displayed for clarity. The Delta (web) **Preview** is shown top right, and **playback** window, bottom right.

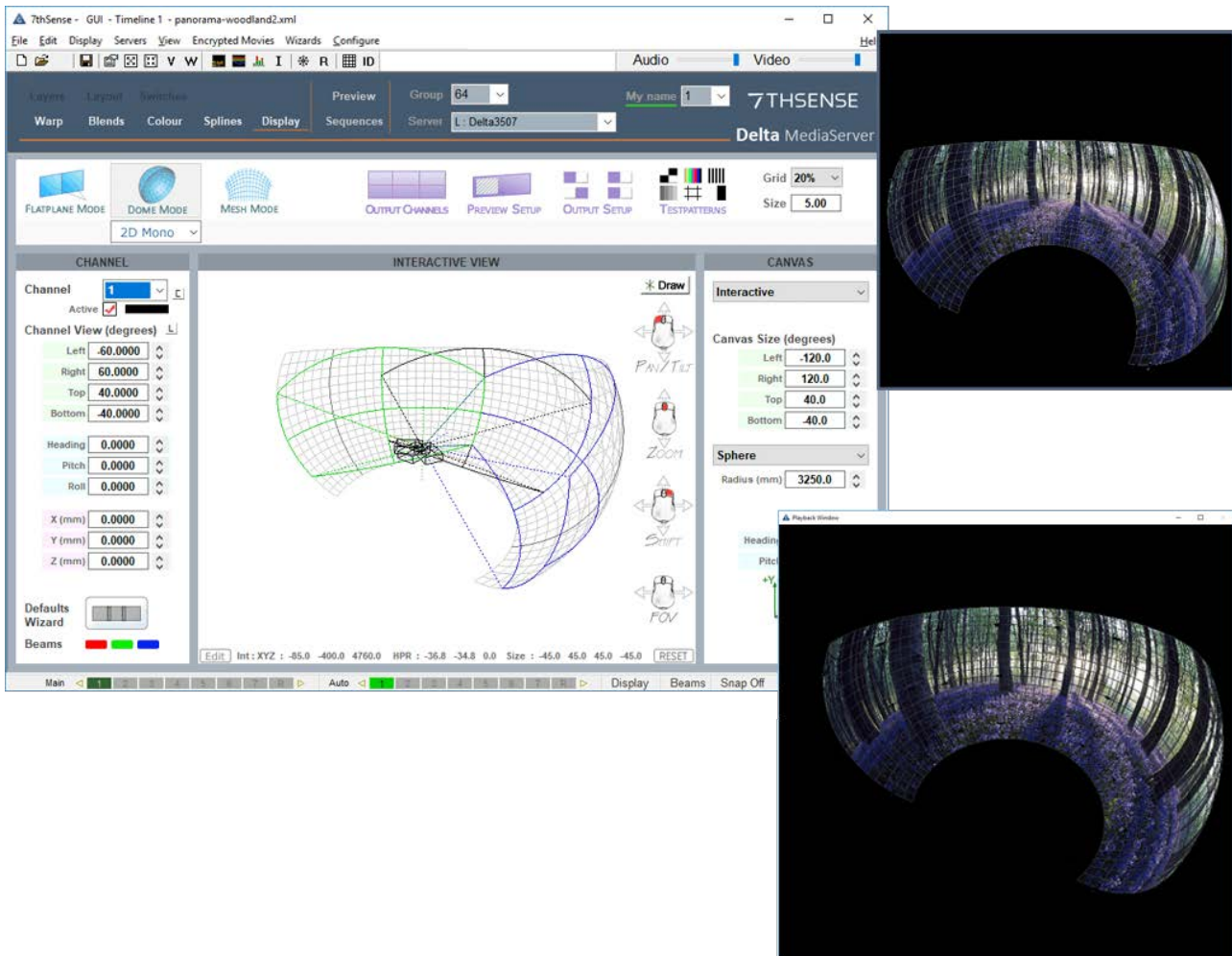

For comparison, the same panoramic image is shown here projected onto a hemispherical dome:

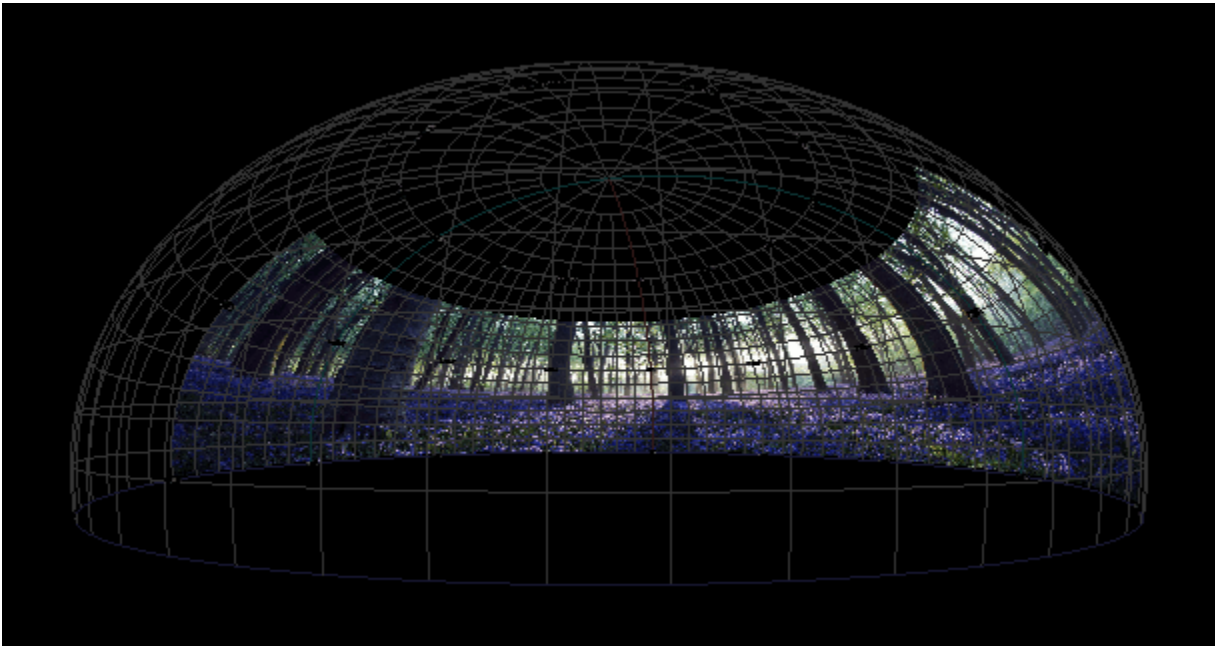

## Autoalignment Process: Preparation

---

### Autoalignment Calibration Data

7thSense recommends Display Manager™ from Scalable Display Technologies for automatic geometric alignment of displays with Delta Media Server. This is a camera feedback system, whereby light and patterns projected by the alignment software are 'read' by a DSLR camera to produce alignment calibration data. This is fed back to the Delta software to project a perfectly calibrated display.

Each Delta server loads the autoalignment data in its directory for Scalable Display autoalignment systems. The default output folder used by the Scalable Display Client is C:\Program Files\Scalable Display\DEI\LocalCalibration.

➤ see [Scalable Display Manager](#) <sup>(209)</sup>

Systems that can export MPCDI standard exchange files can also be used (for example VIOSO), and these files are copied directly into C:\AutoAlignment\MPCDI on the server. See:

➤ [Using MPCDI Data](#) <sup>(217)</sup>

➤ [Using VIOSO with Delta](#)

## Media

Full dome displays usually use fisheye media (square or dome-master format) and typically involve 6 or more projectors. It is important to have sufficient overlap to achieve good blends, and to position projectors for good overall focus and avoiding large incident angles.

## System Setup for Scalable Display Manager

It is assumed that:

- the graphics card setup has been done (AMD: Grouping; NVIDIA: Mosaic)
- Scalable Display Manager, as client, has been already installed by 7thSense on each Delta server being used for the display
- Scalable Display Manager (licensed installation) is installed on a separate laptop PC, on the same network as the server(s).
- DeltaServer has a current Auto Align licence, and Dome Mode licence. Check the 'About' dialog on DeltaServer. You should see Auto Align in the dropdown list of options:

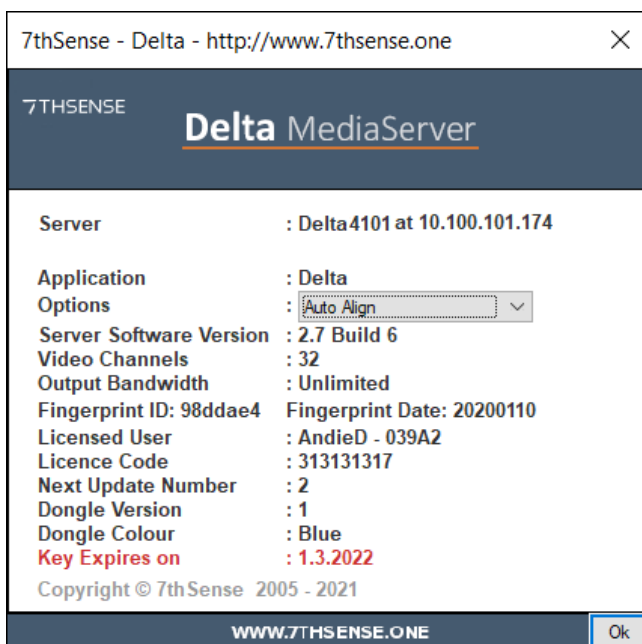

- DeltaGUI *Configure* > *Preferences* > *Startup & File Load* has AutoAlignment, Use Auto Warp, and Use Auto Blend enabled.

- In the diagram below, a Scalable Displays-recommended camera has been set up, with a fisheye lens, facing normal to the pole of the dome, close to the dome spring line, and can see the whole display – but as little more as possible. Unwanted light should be minimised to achieve best contrast for the Scalable software, and kept constant. This camera is connected to the laptop PC using Display Manager.

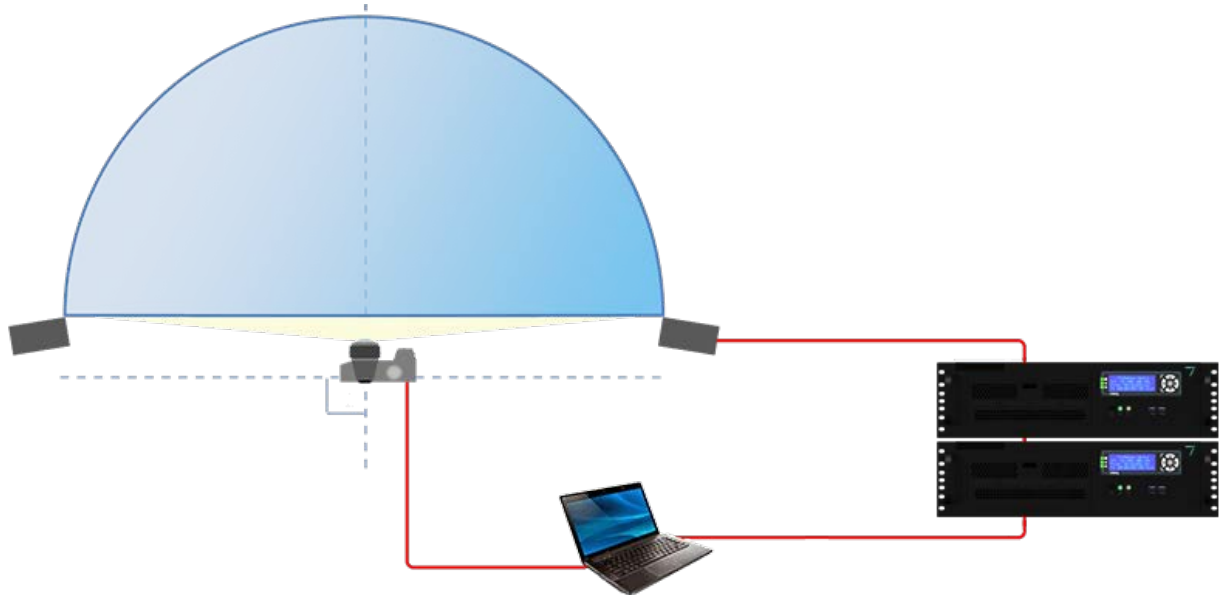

## Configuring Delta to use Autoalignment Data

---

To enable use of autoalignment data within Delta go to DeltaGUI: *View > Preferences > Startup\_File Load:*



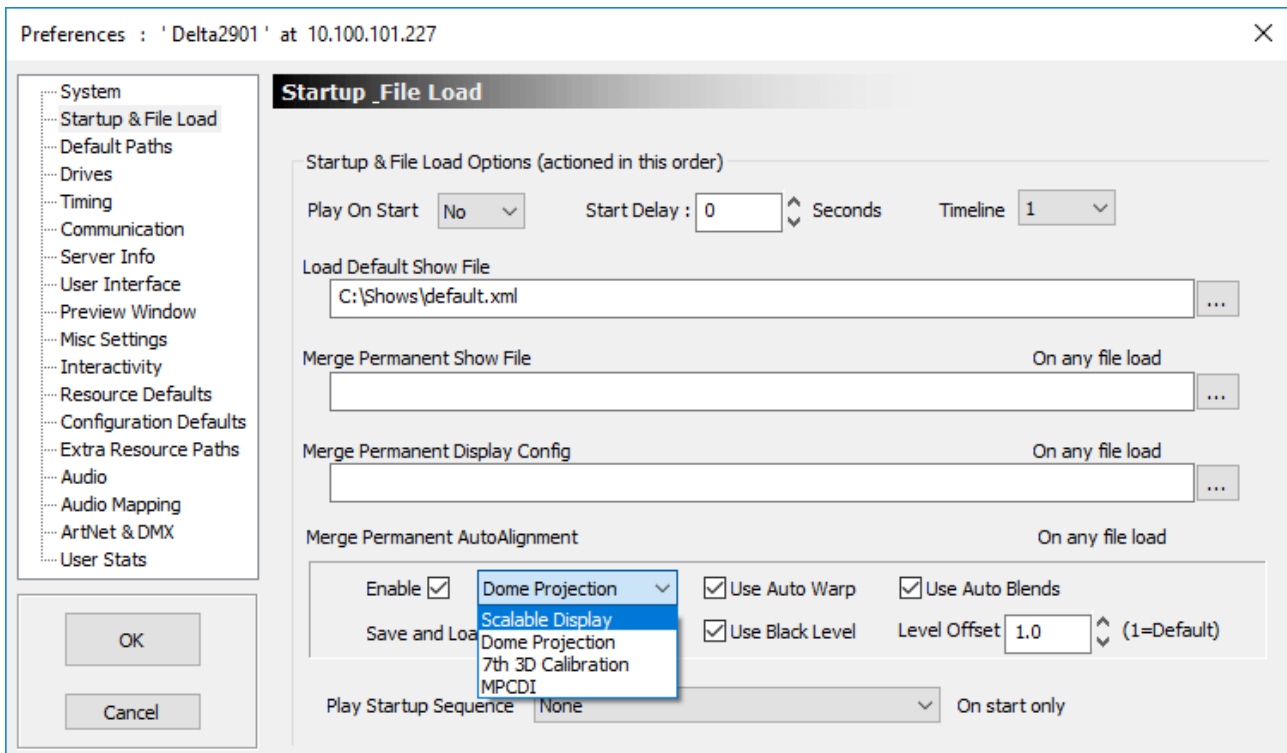

In the *Merge Permanent AutoAlignment* section:

- Select *Enable*
- Select the autoalignment system being used (e.g. [Scalable Display Manager](#)<sup>(209)</sup> or [MPCDI](#)<sup>(217)</sup>).
- Select whether you want to use *Auto Warp*, *Auto Blends* and *Black Level* options (as available to your autoalignment system type: Black Level is currently only available with Dome Projection and MPCDI systems).
- Click OK to accept changes: Delta will import and use the data.
- Delta automatically applies warp, blend and black (as available) when autoalignment is enabled.

Manual Geometry and Blend can be added as normal on top of any autoalignment data.

## Scalable Display Manager

Please consult the Scalable Display Manager User Manual for full details. This is our summary procedure for use with Dome display in Delta.

Scalable Technologies has a range of YouTube video introductions, beginning here: [How to align multiple projectors with Scalable Display Manager 8.0 - Quick Setup Guide](#).

Follow these steps in sequence to create the autoalignment calibration data that Delta requires from Scalable Display Manager.



First check (bottom left of the Display Manager screen) that the camera is connected.

## 1. Display Clients Tab

Select **Use Remote Display Clients**, then find and connect to every display client server.

Assign the IP address of the Delta server to the right-hand column. If it does not appear, try restarting the SDT Display Client on the host PC. This can be found in the Start Menu.

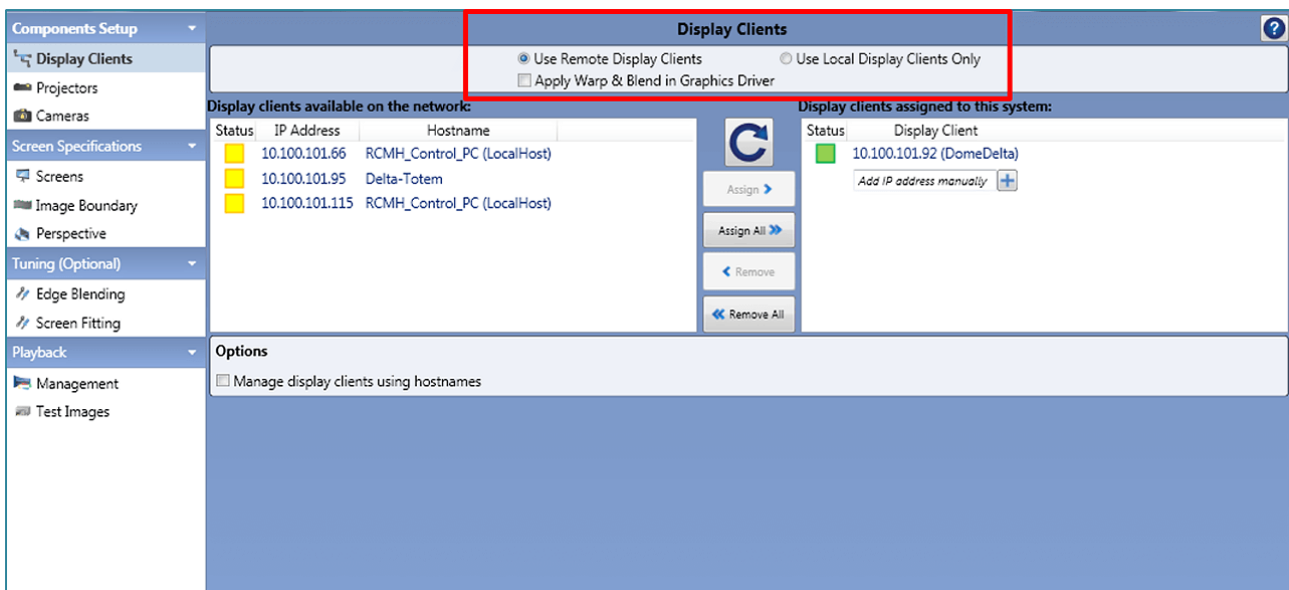

## 2. Projectors Tab

This may take a few seconds to load, and shows what is connected to the Display Client. Make sure the correct number of projectors appear and at the correct resolution. If you set a specific Matrix Mode array in Delta, you should have the same configuration here.

- It is important to disable any unused displays here.
- It is best to make this configuration match your DeltaServer desktop configuration. If it is not automatically correct, use the custom resolution option and number of rows and columns to make sure the layout matches Delta.

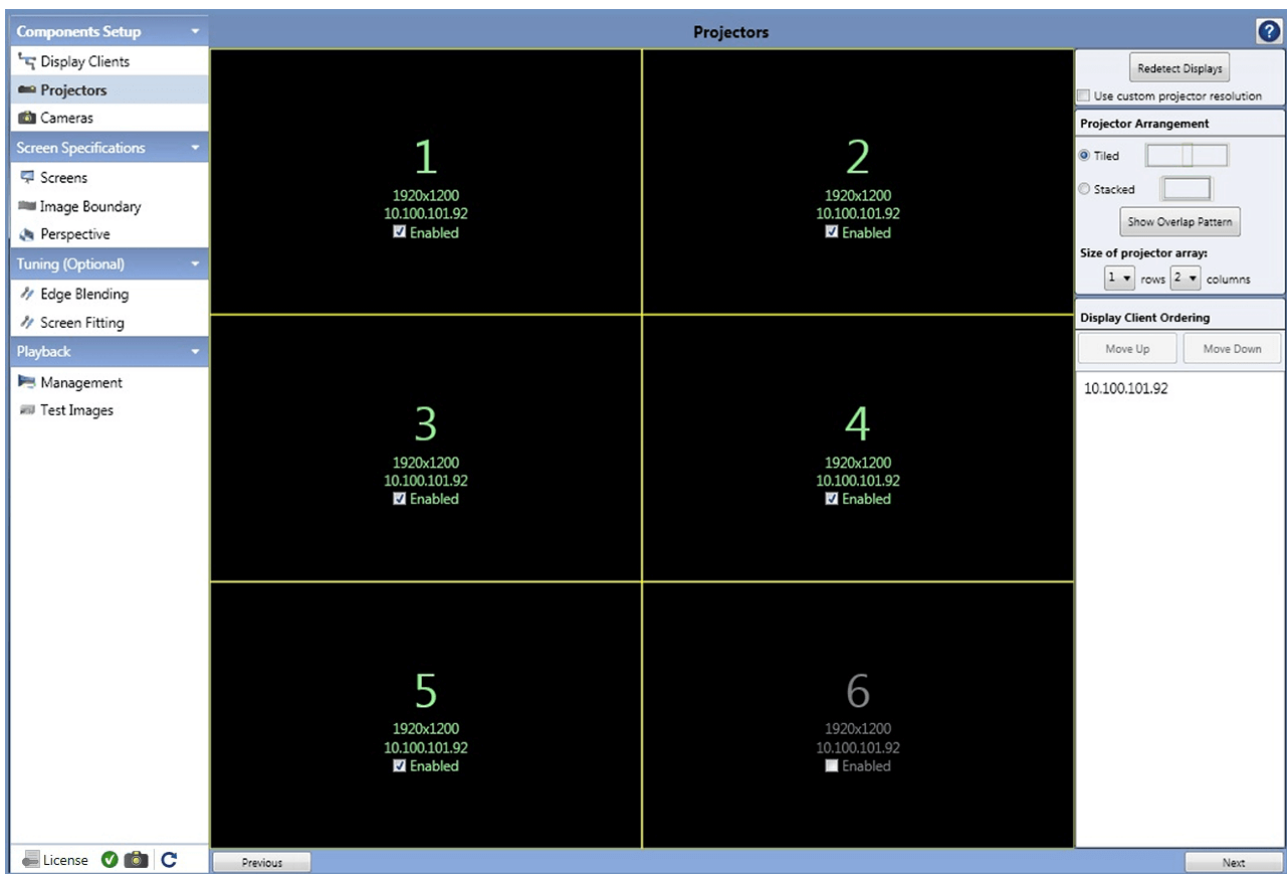

Click 'Next'.

### 3. Cameras Tab

- You are probably using a single camera, so make sure the number of cameras is set to 1, and set the type to 'Automatic'.
- Position the camera normal to the pole of the dome (see [Preparation](#) <sup>(206)</sup>), and make sure the entire screen image is in view and is not over-saturated.
  - The orientation of the base of the camera will determine where North (0 degrees) is.
  - The centre axis of the lens will determine where the pole is.
- Use the 'Show Pattern' button to put up sample grids to help ensure all the spots are visible.
- 'Auto-Tune' can be used for correct exposure, and is often necessary for large displays. It's worth trying without first, as the process is quite robust. If you can get away with the default short exposure time, the alignment can be a lot quicker.
- If setting the camera manually, you could use a 2 s exposure with an aperture of f/7.1 and ISO of 100.
- Project a pattern or static image that has contrasting edges to facilitate focusing, and take a picture with the camera in auto shot and auto focus mode.
- Clear the image and switch the camera to manual shot and manual focus mode.

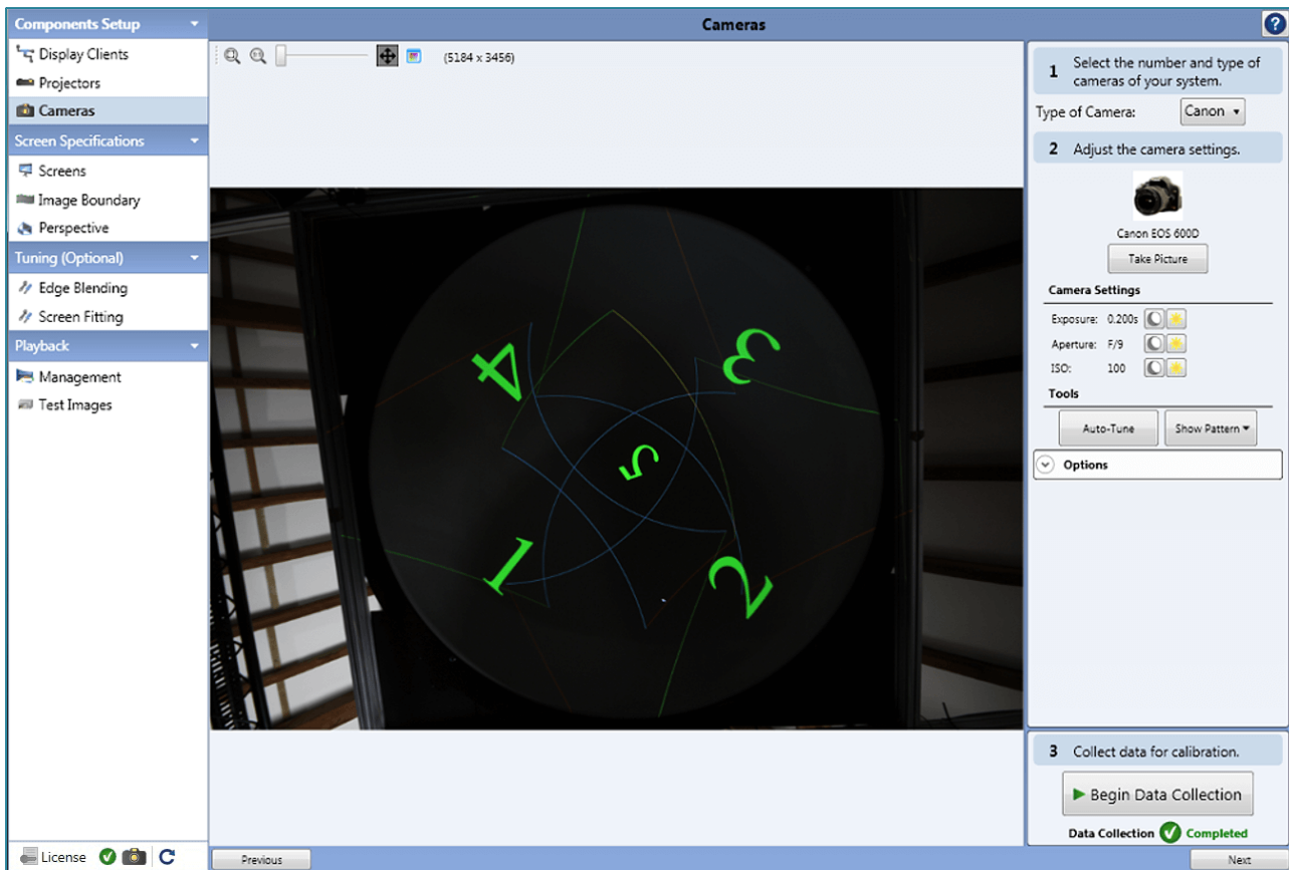

### 4. Collect Data

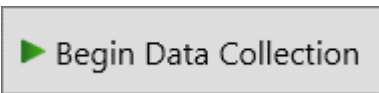

Check the camera has not gone into sleep mode and press Begin Data Collection.

The Scalable software will project a series of calibration images:



White

Used to see the area of a channel, and to auto detect the image boundary.

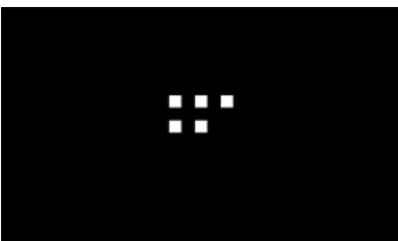

5 square dots

Used to determine orientation and location of a channel.

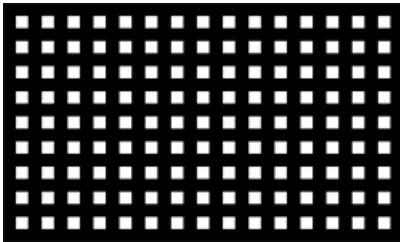

Grid pattern

Used to measure the screen geometry of the channel.

No more images will be taken by the camera unless a new data collection process is required.

When data collection is complete, click 'Next'.

## 5. Screens Tab

### Dome

The Dome screen type. There is no need to change any of the settings so leave them at their defaults of 10 and 90.

### All other types

Select the screen shape you have and enter the appropriate metrics for the screen:

Parameter	Value	Units
Dome radius	10	Relative
Maximum angle	90	Degrees

If you make changes, click 'Update Calibration'.

Click 'Next'.

## 6. Image Boundary Tab

### Dome

It is not necessary to set boundary points here, although you have the option to if necessary. Otherwise use auto detection, and check that the displayed image covers the desired area.

### All other modes

Set boundary points of the screen here.

Click 'Next'.

## 7. Update Calibration

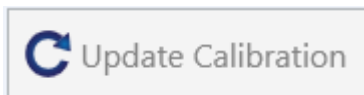

Modify the previously collected data with the new parameters by pressing Update Calibration. You will now need to make an adjustment to perspective that will not affect the calibration.

## 8. Perspective Tab

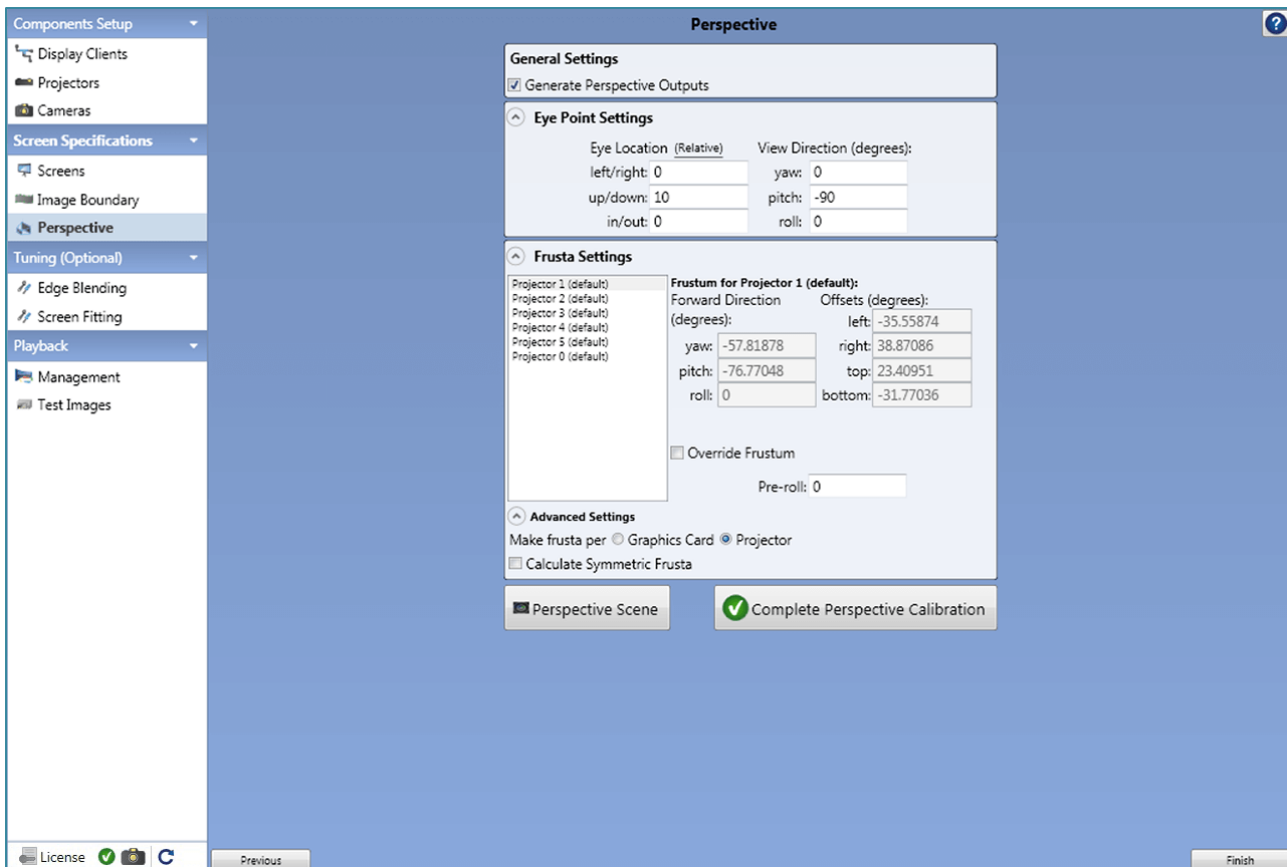

In the *Frusta Settings* > *Advanced Setting* area, towards the bottom of the panel:

- select 'Make Frusta per' **Projector**.

In Eye-Point Settings:

- set the **up/down** eye-point number. This is a representational number for the depth of the dome (= radius, for a full hemisphere) with a default of 10. This should match the screen radius setting in Delta, dome display configuration.
- set the **Pitch** value. The Scalable default views the dome as in front. For an overhead dome, rotate the pitch up by -90 degrees.

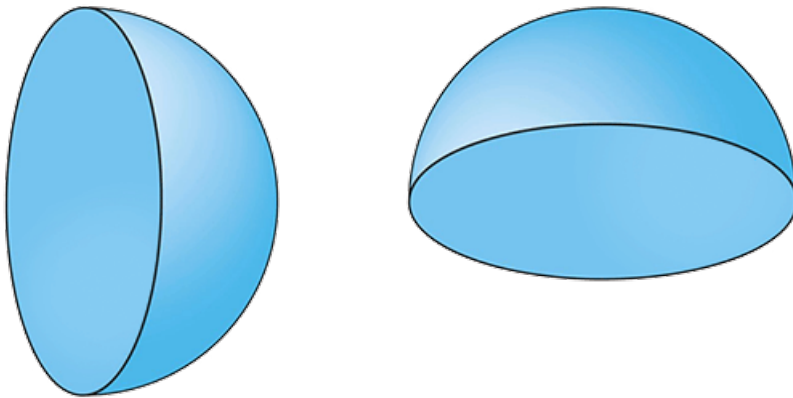

The pitch rotation could be set within Delta rather than Scalable but to avoid confusion, it is better to have the display represented correctly within DeltaGUI.



Click 'Complete Perspective Calibration', and then 'Finish'.

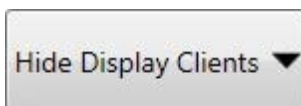

Once the final calibrated image is shown, clear the dome of images. Either click 'Hide Display Clients' in the Management tab, or close the Scalable Display Manager.

**Note:** The image shown as the final image onscreen by Scalable Display Manager may look as though it does not fill the entire screen. This is normal—it can still be fine within Delta.

## 8. Calibration or Recalibration?

The Scalable Display Manager alignment data apply to the relationship between the projectors and the dome. If the projectors have not moved and the camera position is unchanged, then changing input parameters only requires an update. If any projector has been moved, a full recalibration based on new camera images will be required.



Recalibration can also be run from the Scalable Display desktop icon.

## Import Autoalignment Data into Delta

The 'Refresh AutoAlign' button is available in either Flatplane or Dome Mode when autoalignment is enabled in the configuration startup preferences. Click it at any time to re-import the Scalable Display autoalignment calibration data.



The Scalable autoalignment data can be copied from C:\Program Files\Scalable Display\DEI\LocalCalibration into the C:\AutoAlignment\Scalable Display folder to be used on startup: click 'AutoAlign Use as Primary'. Whenever there is alignment data in this folder, it will be used in preference to new Display Manager calibration data.

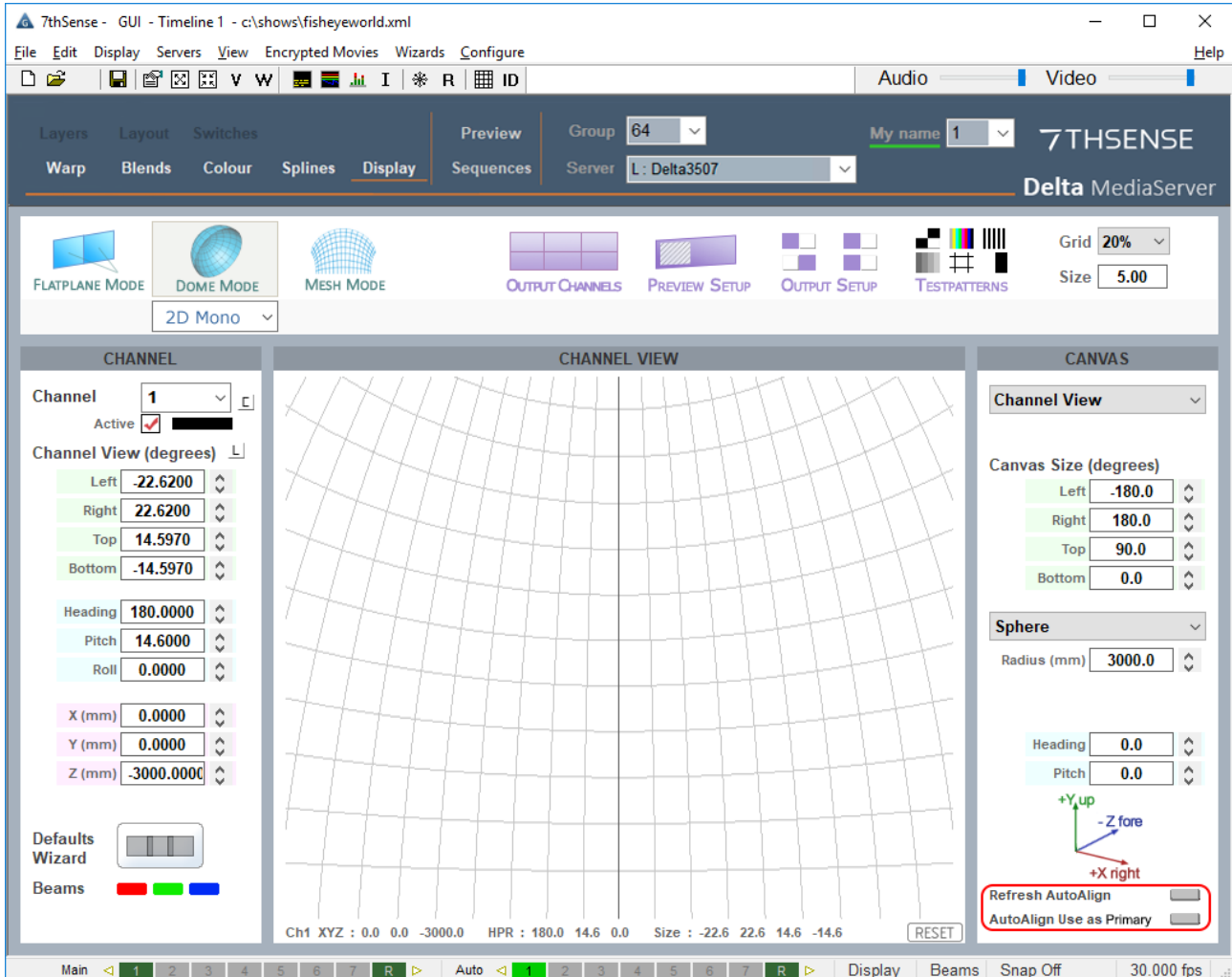

In Dome Mode, small changes to the Delta Radius number will allow you to finely adjust the position of the dome spring line.

## Using MPCDI Data

One of the methods Delta can incorporate is MPCDI (Multiple Projection Common Data Interchange v.2, 2013). It is a common standard for exchange of channel blends and warps and projector positional data as defined by VESA (see [VESA Standards](#)) and can be used to import autoalignment data from VIOSO systems.

MPCDI files are stored in the standard folder for Delta: C:\AutoAlignment\MPCDI.

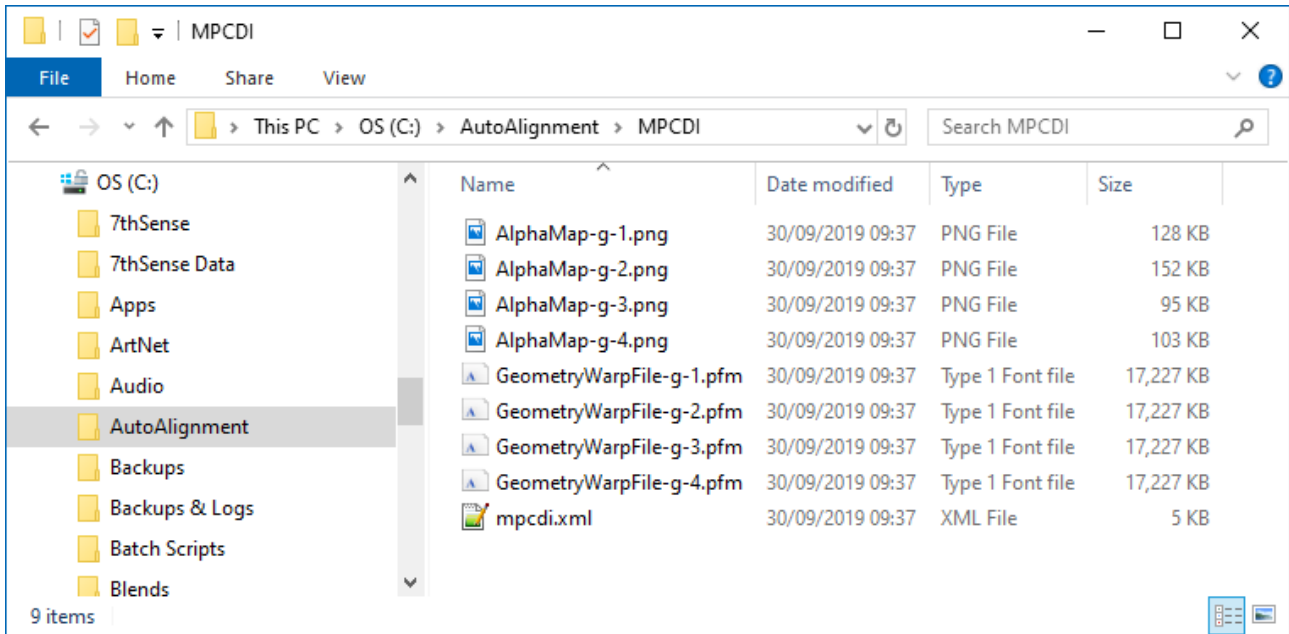

If you are receiving data from a third party source, check if the folder is zipped, and extract, or copy to this folder. The size of these files and the corresponding load that they add is a function of their resolution.

**Note** the file-naming standard, using the prefixes AlphaMap~ for the blend images, and GeometryWarpFile~ for the warps. The matching suffixes after a hyphen (in this example, g-1 to g-4) is what you will see in DeltaGUI. These are the MPCDI regions (Delta: channels). You need to know how these regions correspond to your Delta channel numbers so that you can match them up.

## Configure Delta to Use MPCDI

Enable MPCDI and check the required/available data, in DeltaGUI > Preferences > Startup & File Load:

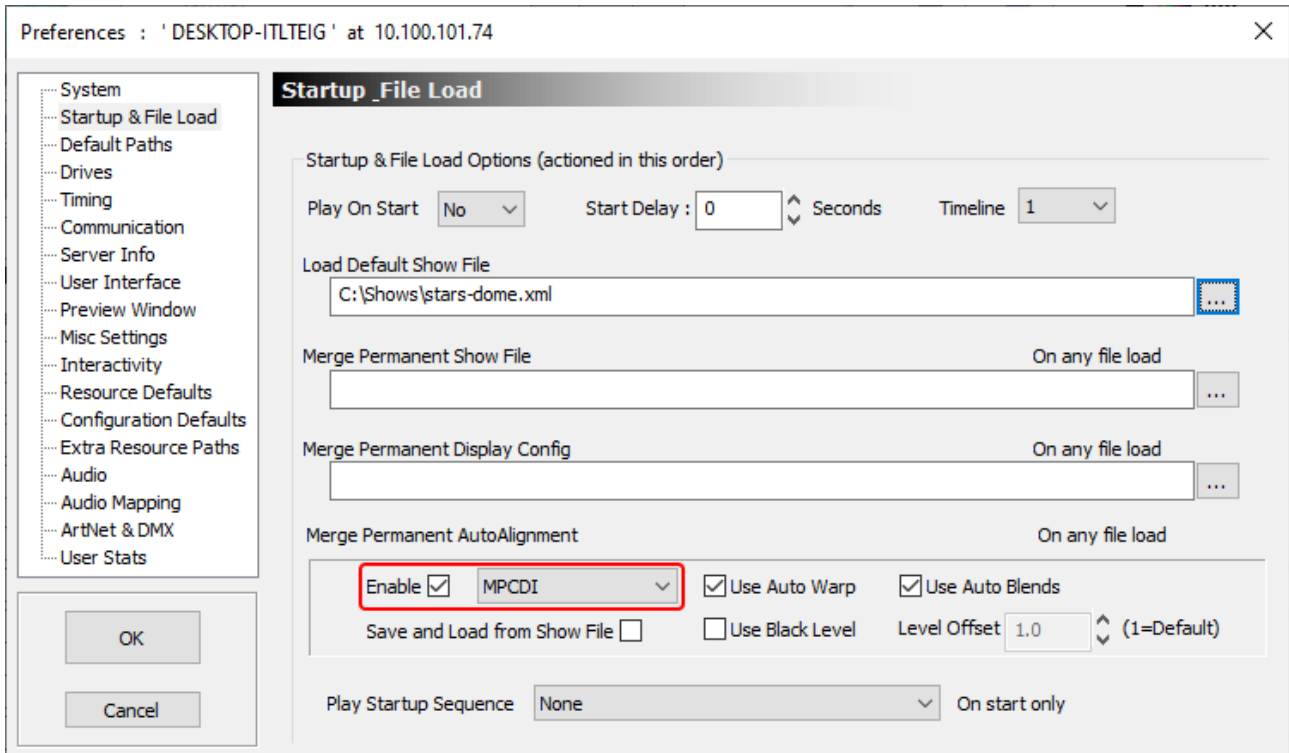

In DeltaGUI > Display > Dome Mode, you may need to click the Refresh Autoalign button. If at the top of the main window you see 'Autoalign Active - Error reading files', make sure you have enabled the right selections and that all MPCDI files are present. You should then see the MPCDI Region Names listed in the dropdown menu:

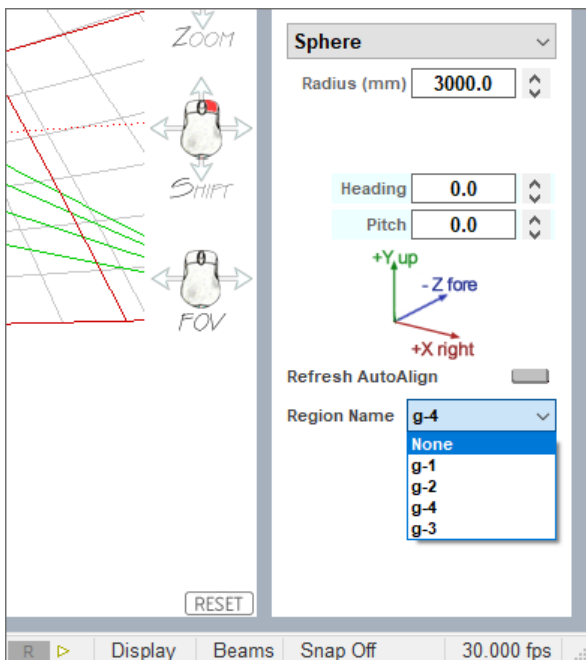

Assign your output channels to MPCDI regions by selecting in turn the Delta output channel (top left), then the MPCDI region (bottom right). You should see the channels come live in Channel View in the colour of the channel:

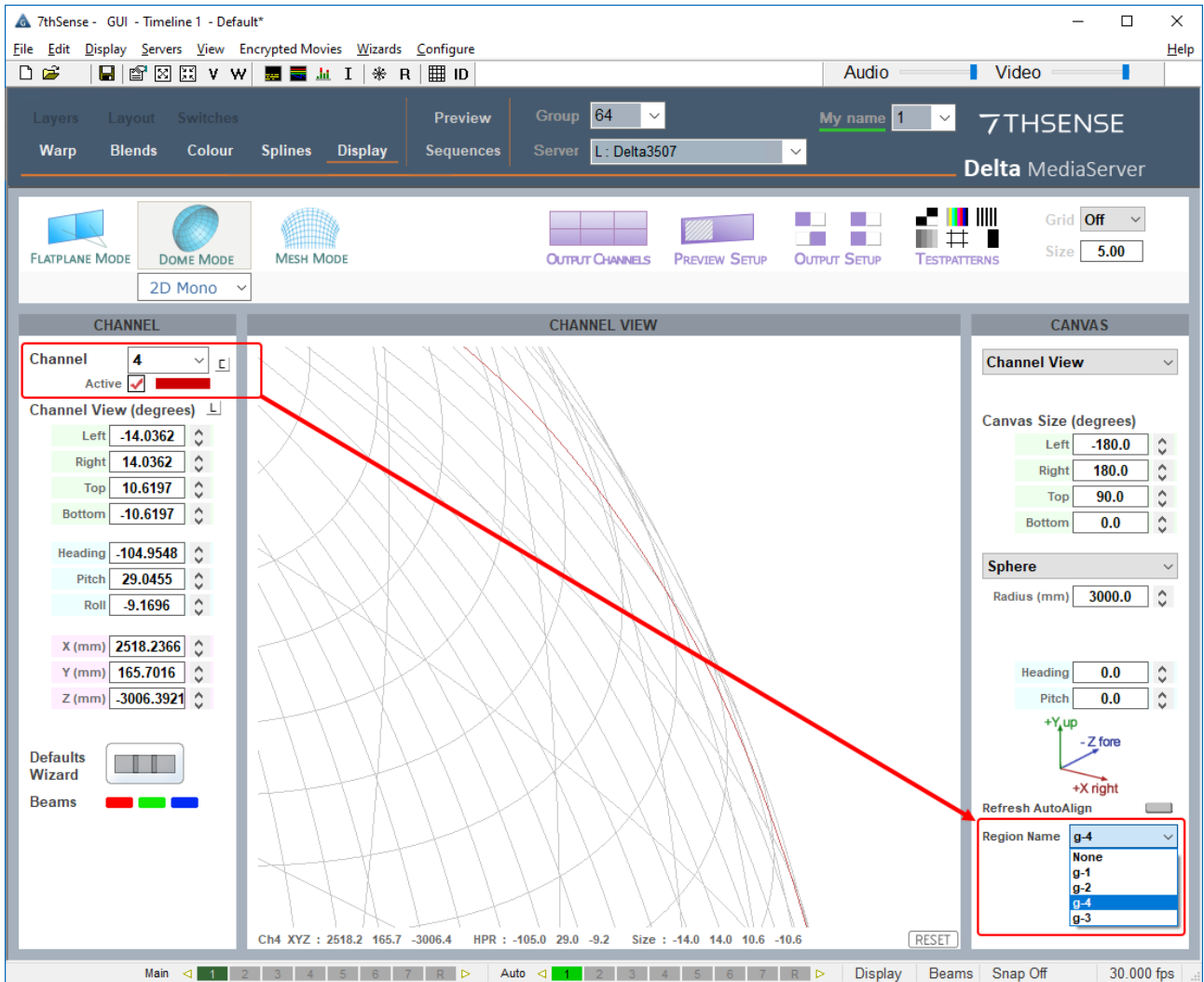

## Display Configuration: Mesh Mode

---



Mesh Mode is a Delta Licence option intended for projection onto complex objects or surfaces. This practice is commonly referred to as 'Projection Mapping'. Really, Mesh Mode could be utilized for even the simplest of traditional applications (e.g. a single projector pointed straight on to a flat projection screen), but most users would feel it introduces unnecessary complexity in applications where our Flat Plane mode plus 2D warp and blend tools can handle the job more simply.

DeltaServer uses a 'model-first' approach to projection mapping, meaning a 3D model (or 'mesh') representing the projection surface is prepared in advance, and then imported into DeltaServer for media texturing and projector alignment. This is opposed to a 'projection-first' or drawn-on-site workflow used by some other tools (generally more VJ-type 'rock up and do something neat' tools). The 3D model is generally instrumental to the media creation phase of a project as well, which often happens months in advance of going to the site. So, depending on whether the physical surface already exists yet in the world (e.g. a historical building) or not (e.g. some new sculpture that isn't built yet), the initial model may be software-originated or produced by laser-scanning. Often with a software-originated model, a laser scan is performed once the physical object does exist, and the planning model is then corrected against the laser scan 'point cloud' result by overlaying it in the modelling software.

This guide will take you through the process of matching your mesh model and media to the real life environment. The two major stages of projection mapping in DeltaServer are:

1. texturing content onto your 3D model in the virtual world
2. resolving alignment of the real world projectors relative to the model.

## Projection and Textured Modes Explained

---

### Projection Mode

Projection Mapping is the art of using projectors to paint media onto complex surfaces. Most projector lenses are designed for tangential mapping, meaning that when a projector's light source produces an array of pixels and passes that through, the lens is designed to produce a uniformly lit, uniformly focused rectangle of light on a flat plane surface. Success depends on the projector being pointed square at the surface, and the surface reflecting the light uniformly back to the viewer's eyes. The key challenges of projection mapping are therefore dealing with geometry and luminance (the intensity of light reflected/emitted from a surface), compensation or compromise, when projecting onto non-planar objects with varied surface properties, generally from multiple blended projectors shooting from disparate angles, and often in environments where viewer position varies greatly.

All these factors should be considered in planning a projection mapping. Simple, right? Tools like DeltaServer hide much of the challenge by predicting geometry and light behaviour in a 3D space. The resulting image relies on a sensitive static relationship between projectors and surface, so care

should be taken in installing the projectors in relation to the target, in a stable manner that will change as little as possible in the future. Any changes will result in the need for alignment adjustment.

### The 3D Object/Surface

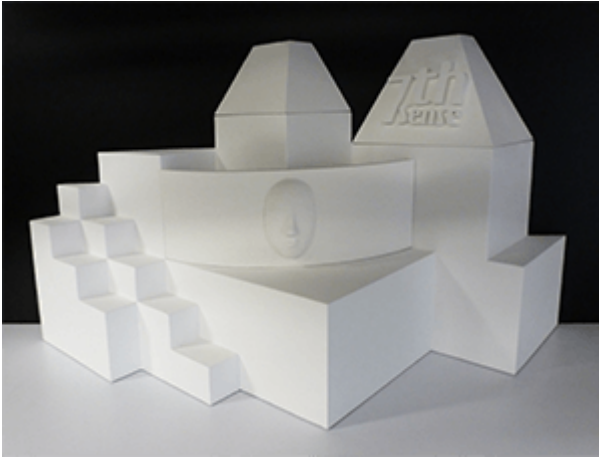

Geometry and light predictions are accomplished by placing a virtual camera representing each real world projector in the software's 3D space, whose X, Y, Z, heading, pitch, roll and lens characteristics closely match that of the real world projector lens. So long as the geometry of the 3D model accurately matches that of the real world object, you will accomplish an accurate reflection of that camera's view of the textured software model back onto the real world object.

Texturing the model means defining how 2D content will be applied to a 3D mesh of faces. DeltaServer supports both explicit UV maps (a list embedded in the .obj model file, defining relationships between 2D canvas x,y percent positions to 3D points on the model), as well as eyepoint-based virtual projection.

### The 3D Model

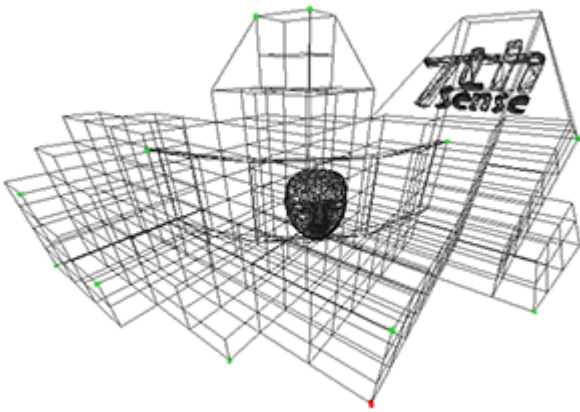

A 3D model is a system of co-ordinates ('nodes' or '**vertices**') joined in a mesh. The co-ordinates take as their reference a zero-point (or **origin**) within (or outside) the model of the reference object. The model can be rotated and viewed from any angle, but when used for projection mapping, the designer will take a chosen viewpoint (or **eyepoint**) that 'projects' an orientation from which the object will be viewed.

## The 2D Media



Because the designer's reference point is the origin of the model, the media effectively represents what the origin of the model would see in a mirror. For better and sharper results, the media can be displayed over several projectors, and it may be better to split a complex mesh model into more manageable pieces for those projectors, but projection mode still assumes that the designer and viewer are both looking at the media-painted object from the same view of the model.

## Textured Mode

### The 3D Object/Surface

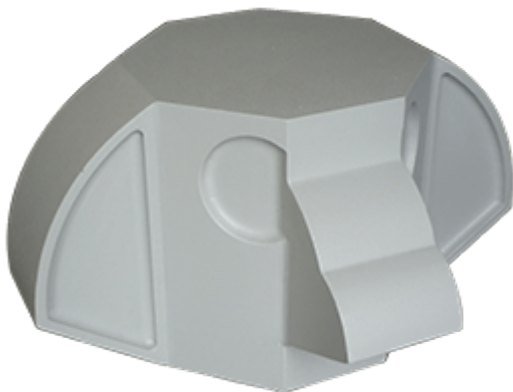

Just as the 3D model can be rotated and viewed from any angle, so the viewer can either move around the model, or the object can be rotated, and the media will 'stick to' and move precisely with the object.

Here is a demonstration model of a totem head with easy-to-identify surfaces.

### The 3D Model

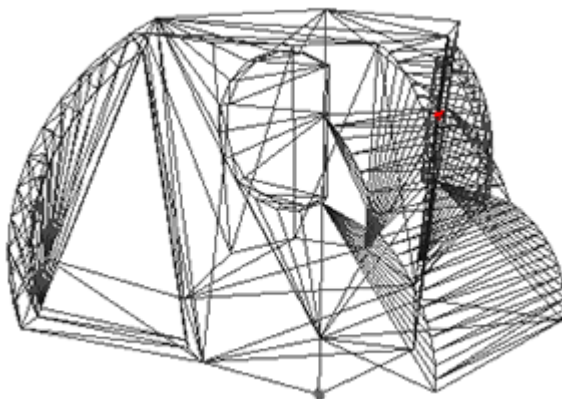

The 3D model is constructed in the same way, but its entire external surface is notionally 'peeled off' or unfolded onto a flat surface. This surface is 'painted' by the designer to create specially rendered 2D media. Whilst the object and model are described in  $X \times Y \times Z$  axes, the surface is described in the 2D  $U \times V$  axes, hence UV-rendered or mapped media.

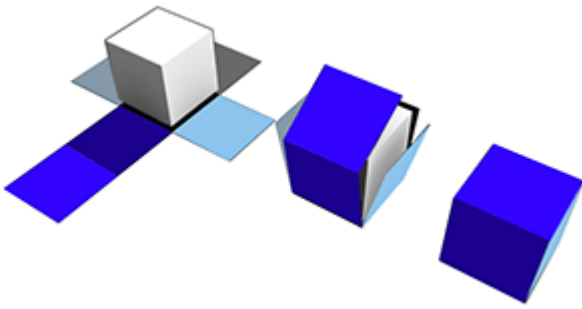

In this illustration a simple cube demonstrates the theory of what can be actually a more complex mapping, as in the 'totem head' example used here.

**The 2D UV-Mapped Media**

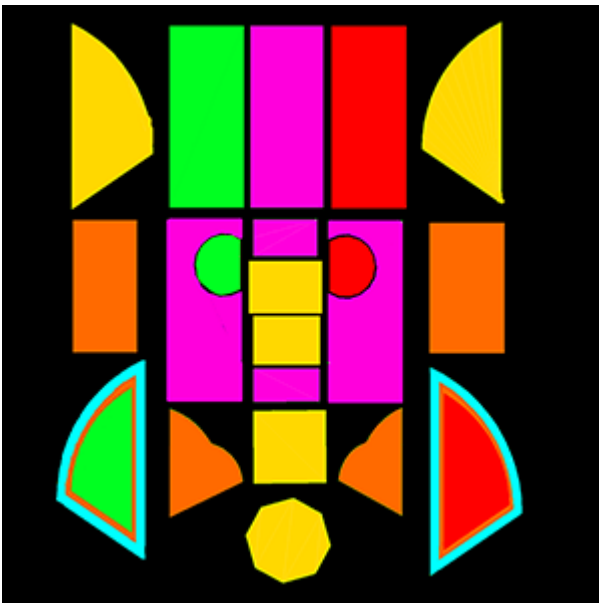

For the designer, all viewpoints now are perpendicular to the model/object surface, rather than, say an oblique view of the side of a cube. In textured mode, the characteristics of the mesh model surface are 'baked' into the flat media, which is then folded back onto the model in the projection.

Compare this UV-mapped media frame with the one used above for projection mode. The top row of faces are projected on the other side of the object, either by rotating the object into projector view, or by providing all-round channel coverage.

The reason this media does not look simply unfolded as in the cube above, is that this would create a lot of empty space in every frame. Instead, the elements are packed into the 2D space, with mapped coordinates that are used to place them on the target object or canvas.

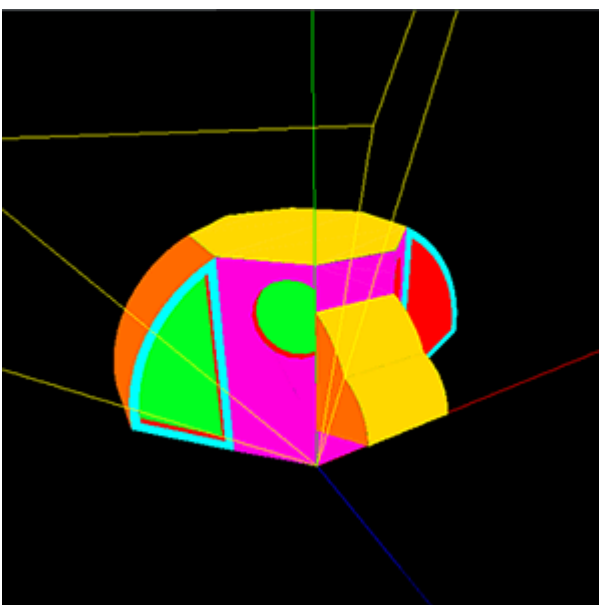

This is how the UV media looks in the Playback Window when 'folded' or positioned back onto the model, as seen from a single channel. The yellow lines show the model origin (X,Y,Z = 0,0,0); red, green and blue are the X, Y, Z axes.



## Mesh Mode Setup

---

### How Mesh Mode works

In mesh mode generally, there are a number of key elements:

- Representing a real-world object as a 3D mesh of points (saved in a .obj file).
- For projection mode situations, designing flat media with a defined eyepoint.
- For texture mode situations, 'unwrapping' the 3D mesh model onto a 2D UV surface, and mapping the media onto it.
- Calibrating the virtual positioning of projectors in Delta, to their precise real-world positions.
- Using DeltaGUI to relate the software mesh model in the server, back to the real world object and projector positions.
- Using DeltaGUI to apply warping and blending for seamless joins and perfect fit.

### Flat Projection Mode

Here is an example of a theatre for display in mesh mode, with a 3D canvas and two offset projectors:

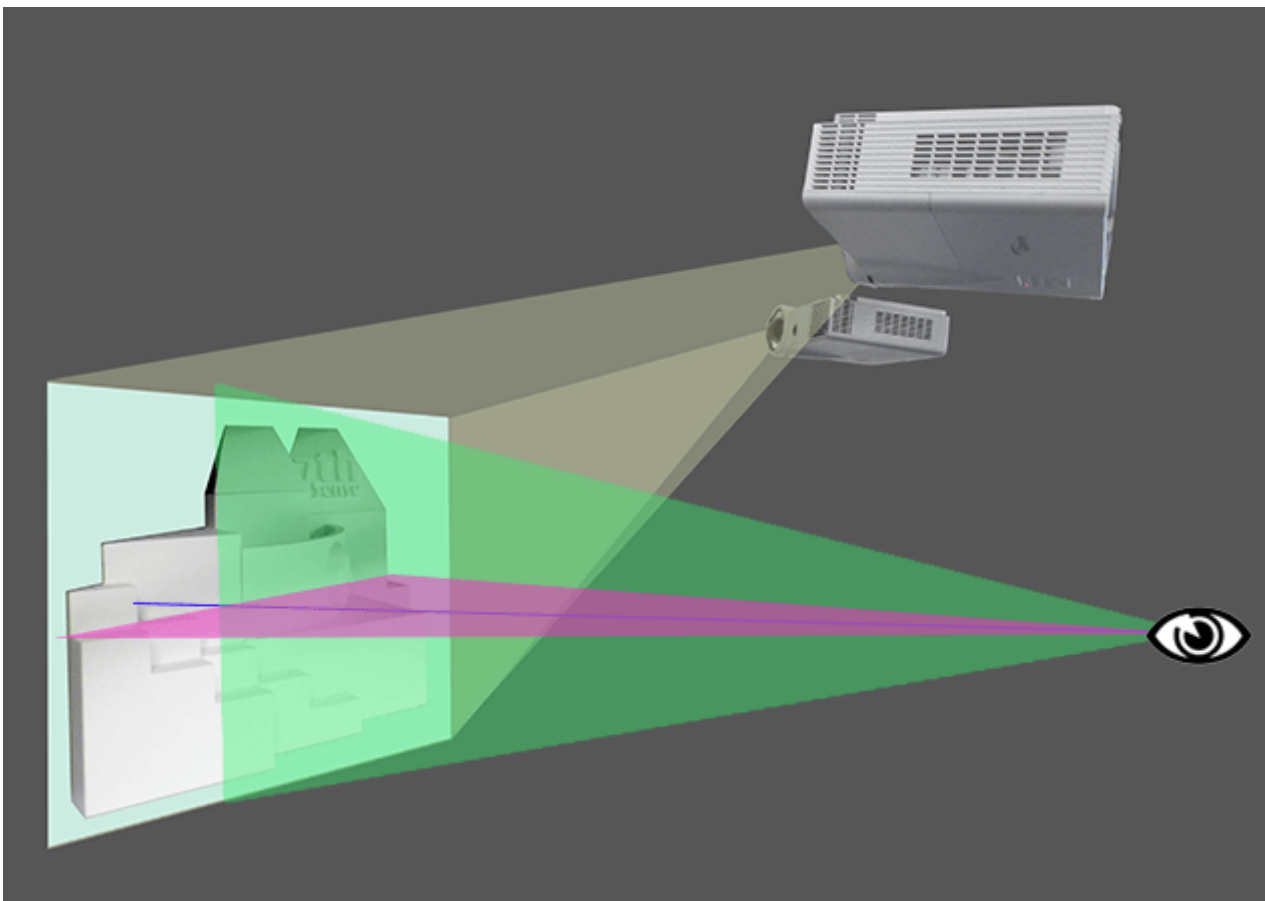

This test model features flat and curved surfaces, detail in the 7thSense logo, and a face with a highly detailed mesh, in front. Whilst the projectors are pitched down, the design eyepoint (red and green axis planes) is horizontal. Here is how each virtual projector in DeltaGUI will see the canvas (in this case a 3D object), and note that they may see surfaces the viewer is not designed to see, or even for which there is no media coverage (Playback window, media disabled, grid displayed at 100%):

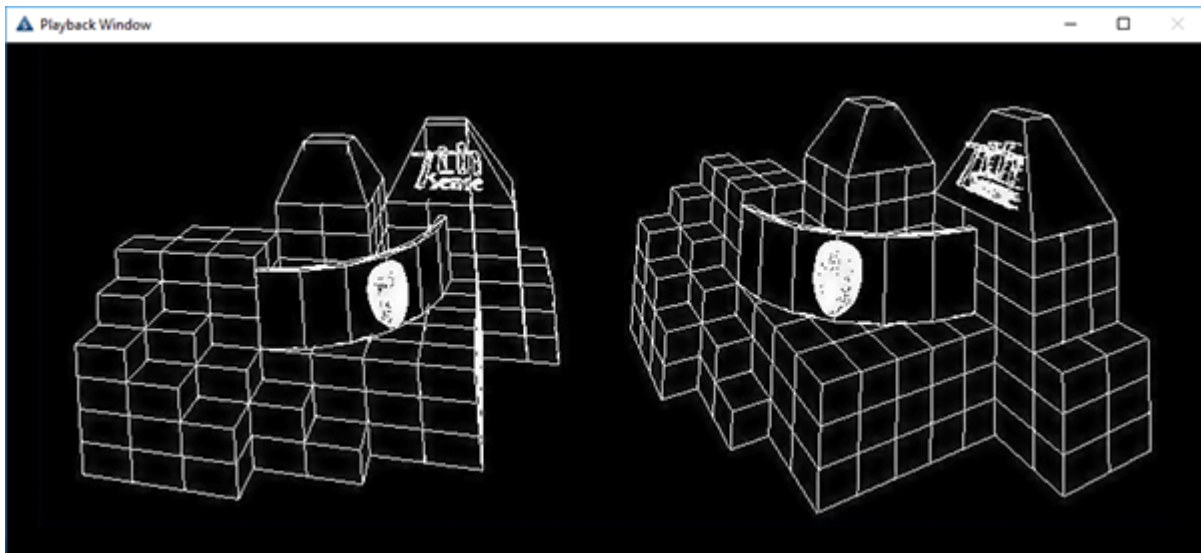

- In Delta, we must set up the render camera eyepoint of non-UV media, as defined in the media. This we do know exactly.
- We also need to know the projector locations for pitch, heading and field of view – but we can't know these exactly.
- By giving Delta enough reference points from the .obj file, placed in real space, Delta can work out how to warp the flat media from any angle, into exact position.

Already we can see that projecting non-UV-mapped media onto very oblique faces may reduce sharpness, and in this model it may even be better to have a separate mesh for the face on the front, with a separate head-on projector to avoid shadows. Delta can handle up to 16 meshes per show, and 32 channels.

## Textured (UV-mapped) Mode

The theatre setup may be the same as above, but the UV-mapped media will be wrapped to the surface exactly the same way as the .obj model grid shown. Alignment is much easier, though the media construction is more complex.

## Mesh Setup Basic Sequence

---

### Assumptions

- You have a theatre set up with projectors and display canvas / objects.

- You have .obj mesh files that cover every part of your display.
- You have media that is either for flat projection, or is UV-mapped to the mesh, for textured mode.

### Sequence in DeltaGUI

1. Check your canvas size and render settings : *Display > Mesh Mode > Mesh Canvas*
2. Set your active channels : *Display > Mesh Mode > Channel*, and
3. use the *Defaults Wizard* to distribute your virtual projectors.
4. Add your mesh files : *Display > Mesh Mode > Mesh > Mesh Files*
5. Set your parameters for each required eyepoint (not required for UV-mapped media in textured mode) : *Display > Mesh Mode > Mesh > Eyepoint Files > Eyepoint Details + Parameters* (see [Setting an Eyepoint in Delta](#)<sup>(227)</sup>), and
6. assign eyepoints to the meshes where they are to be used.
7. Set your eyepoint mode to 'Use Texture Coordinates' (not required for flat media in projected mode) : *Display > Mesh Mode > Mesh > Eyepoint Files > Eyepoint Details*
8. Use [3D Projector Calibration](#)<sup>(235)</sup> with any timeline media disabled and full grid display on, for **each channel** to select and align **each required mesh**, with the projectors and real-life canvas. For this stage, keep all channels active, but turn beams off except for the channel being aligned.
9. Apply (or enable) timeline media and view for where correction and adjustment is needed.
10. [Edit the mesh](#)<sup>(259)</sup>, apply channel distortion, or media warps to correct for real-life canvas, and minor .obj or media errors.

## Setting an Eyepoint in Delta

---

Eyepoints are always associated with meshes. UV-mapped media for textured mode effectively has an infinite number of eyepoints, but for projected mode, there will always be one precise eyepoint in the media. If you are not using UV-mapped media in textured mode, then you must obtain the eyepoint data from the content creator, or from within the media (e.g. Cinema 4D).

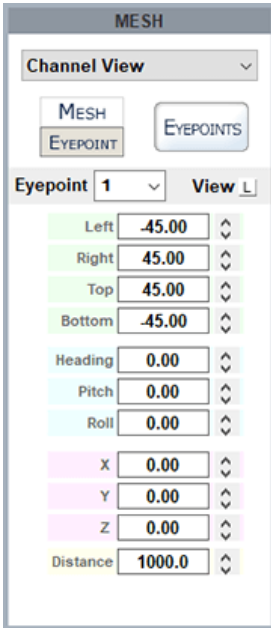

In Channel or Interactive view, click Eyepoint to view the Eyepoint parameters. Using the small L button, make sure the field of view (FOV) parameters are displayed as Left / Right / Top / Bottom (rather than lens aspect and zoom). Each set of parameters is just a translation of the other, but for translating render camera data from Cinema 4D, we need this view.

Enter the eyepoint data, as translated from C4D render camera details:

DeltaGUI eyepoint	Cinema 4D FOV
Left	(negative) of horizontal FOV × 0.5
Right	(positive) of horizontal FOV × 0.5
Top	(positive) of vertical FOV × 0.5
Bottom	(negative) of vertical FOV × 0.5
Heading	(negative) of C4D value
Pitch	(positive) of C4D value
Roll	(positive) of C4D value (most likely 0)
X	(positive) of C4D
Y	(positive) of C4D
Z	(negative) of C4D focal length

## DeltaGUI Mesh Mode Controls

With DeltaServer running and the Playback Window in full screen, select Mesh mode in DeltaGUI. Choose your required 2D or 3D media mode from the Mesh Mode drop-down:

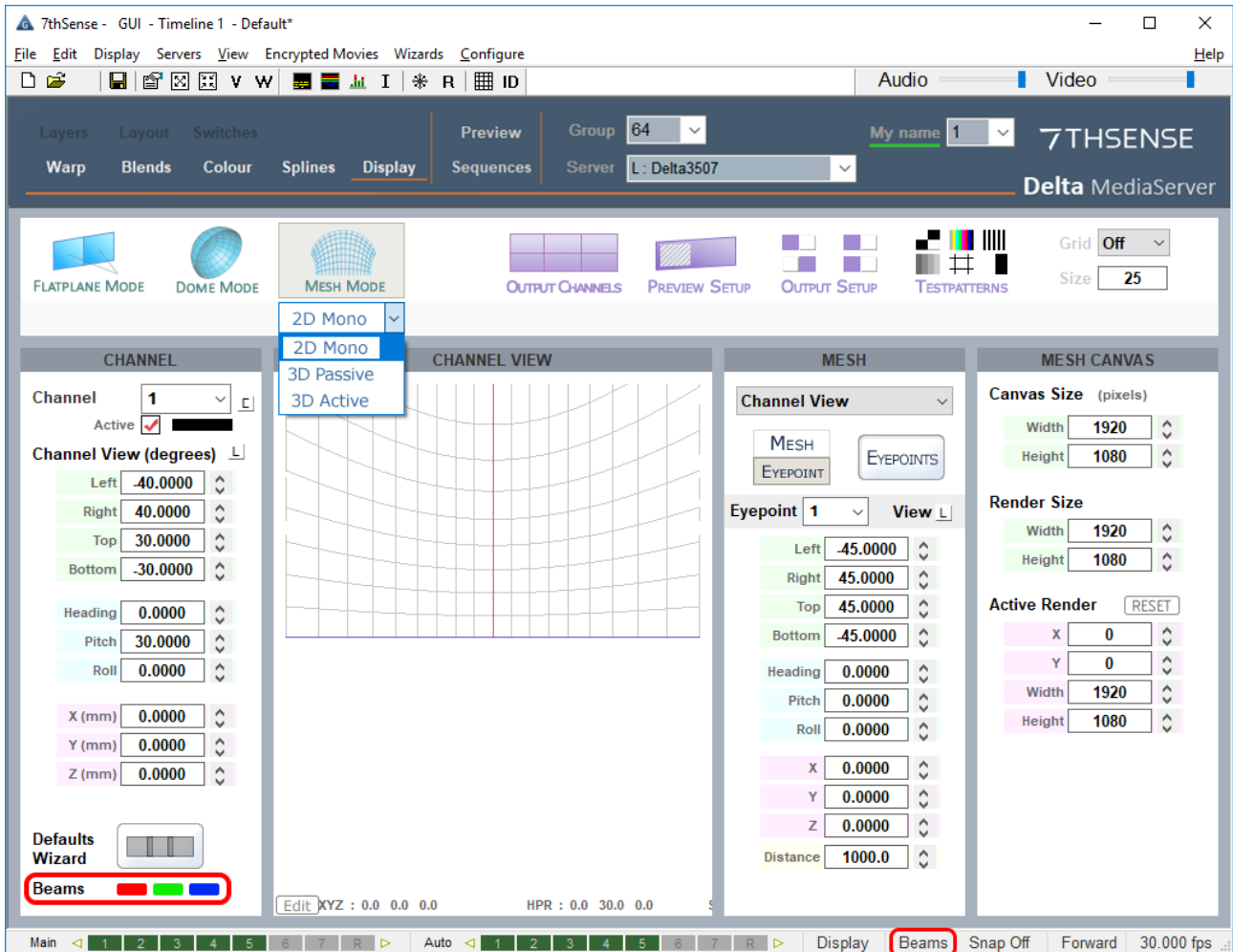

There are three control panels here:

## Channel Panel: Setting up your Projectors

Here you set the projector positions as in any mode. The process of calibration will automatically make fine adjustment to these.

As for any mode, select the active channels you will be using, with the small 'C' button.

**Note** the two places where **channel beams** can be switched on and off: in the foot of the channels panel (click the colours), and bottom right in the DeltaGUI status bar. You will need to switch beams off for calibrating individual channels. Do not deactivate channels for this operation.

The **defaults wizard** dialog behaves the same as Dome Mode, but be aware you are typically arranging channels around an object at a centre, so use Projectors Outside Screen. Note that 'Include Cap' is not relevant to this mode.

### Channel Size

Select from the two options. Use Existing Size (if the display model is the same as previous show) or Force Size and type in the settings according to the design guidelines.

### Channels Used

Select the number of channels (projectors) in 'Force n Channels', or 'Use Existing Channels' if active channels already set up.

### Screen

Set screen radius here if using 'Projectors at Screen Edge' in channel arrangement, or Use Existing Screen if using 'Projectors outside Screen'.

### Spacing

If set to **Calculate**, projectors will be assumed to be all-round, in equal divisions of 360°. Changes to each projection can then be adjusted accordingly at a later stage.

### Channel Arrangement

For Projectors at Screen Edge set a screen radius above; for Projectors outside Screen set a radius here.

### At Radius

This is the visualised distance from the object origin.

## Mesh Canvas Panel

### Canvas Size

Your dimensions here for projected (not textured) mode will be defined by the media.

### Render Size

This is for tuning performance by reducing resolution to decrease the load on the graphics card. (Preserve the aspect ratio.)

### Active Render

This is the location of the render on the overall canvas.

## Mesh Panel

Here, you have five different **views**:

- **Channel**: shows the view of the mesh surface covered by (as 'seen' by) a single channel in the GUI. It is here (or Interactive view) that you set a fixed eyepoint.
- **Interactive**: allows the whole model, axes and projector frustums (yellow lines) to be rotated and viewed in the playback window:

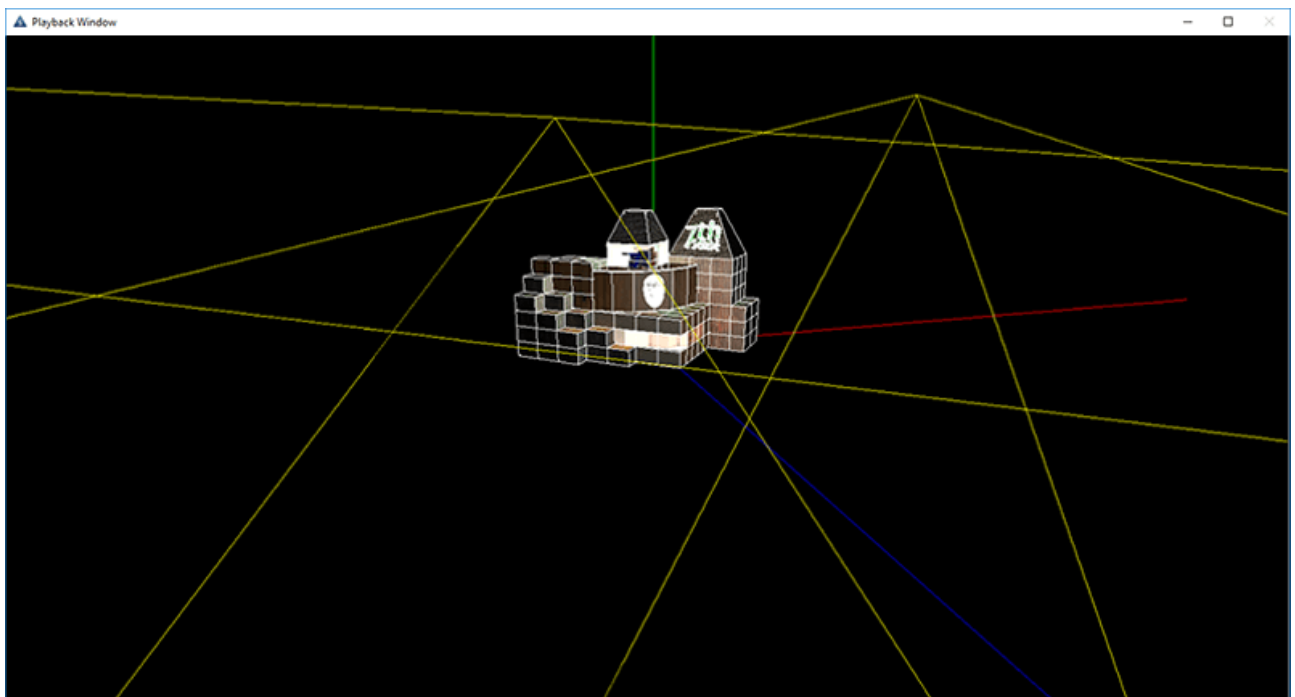

- [3D Projector Calibration](#)<sup>(235)</sup>: place the mesh vertices on the actual canvas points
- [Mesh Editor](#)<sup>(259)</sup>: alter the mesh by overlaying adjustments
- [Movement Nodes](#)<sup>(267)</sup>: synchronise media movements between eyepoints and between meshes.

For projection mode (not textured) you must know the design eyepoint for the media, for each channel.

## Mesh Dimensions

3D models are 'ideal', and even if used as the basis for constructing the actual real-world object (our canvas) there will be differences. DeltaGUI provides for all reasonable adjustments, but the mesh model must be accurate and to scale. Beyond this, the mesh itself may require editing.

- First of all, the eyepoint of the designer/viewer must be related to the **origin** (X, Y, Z = 0, 0, 0) of the mesh model.

Typically left as 0, 0, 0, you can reposition the object away from its inherent origin if necessary.

- If there is a difference in the **scale** of the model and the actual object, this must be adjusted.

Set to 1.0 by default. You can adjust the size of the model if the object dimensions are not fully to scale, but of course the projector locations may then have to be altered to account for the new object size.

- If there is any difference in **heading, pitch** or **roll** of the actual object from that expected by the projected media, these too can be adjusted.

Heading, Pitch and Roll values are in degrees. The 3D object may come in rotated about the wrong axis, so you can correct this here.

## Mesh (.obj file) Selection

For DeltaGUI and DeltaServer to work together, each mesh **.obj** file must be on both the DeltaGUI PC and the server, in **C:\meshes**. When you assign a mesh in DeltaGUI, a copy of the server mesh will be synced to the DeltaGUI PC. Their filenames must stay the same in both locations.

In Channel view, select both mesh and eyepoint for each channel:

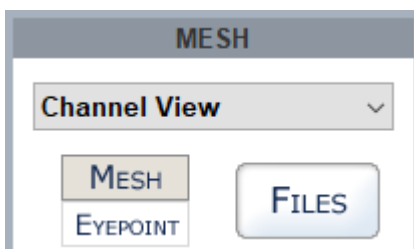



Double-click an ID line to add or to remove a mesh from a channel. You can apply multiple meshes per channel, up to 16 per show.

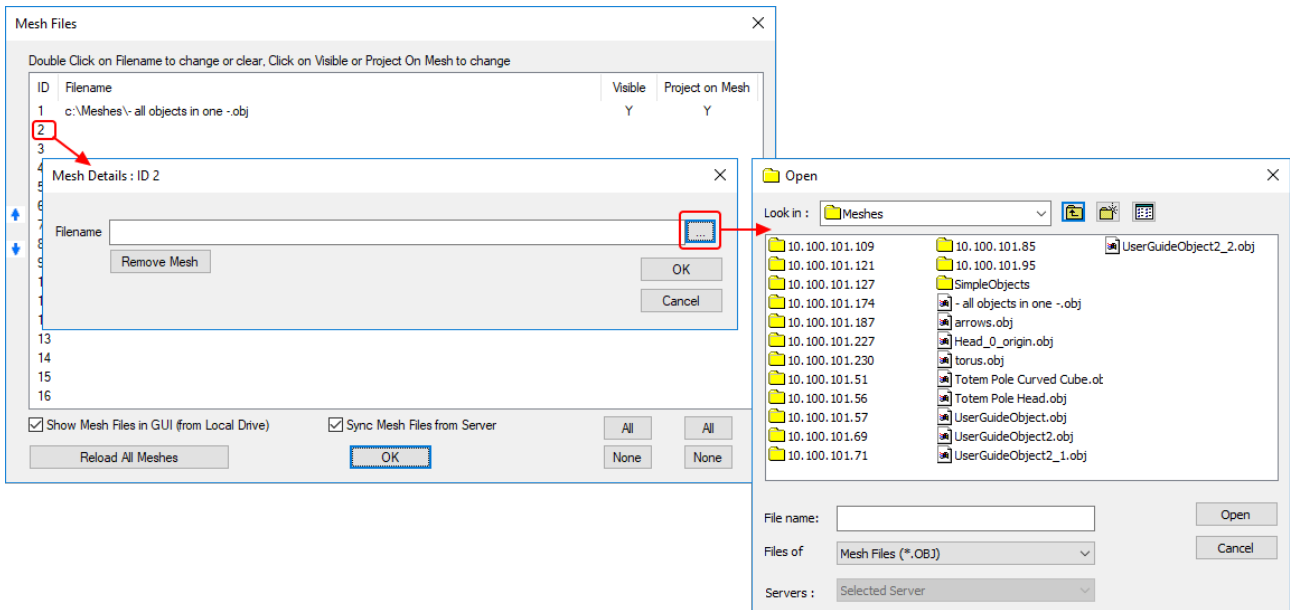

Note in this illustration that meshes synced from other servers have been acquired in folders with those servers' IP addresses.

**Visible**

A mesh can be assigned but only be visible in the GUI, not playback, by selecting No.

**Project on Mesh**

If you do not want media to appear, but you still want to be able to see and illuminate the object with the grid off, a mesh can be rendered in greyscale.

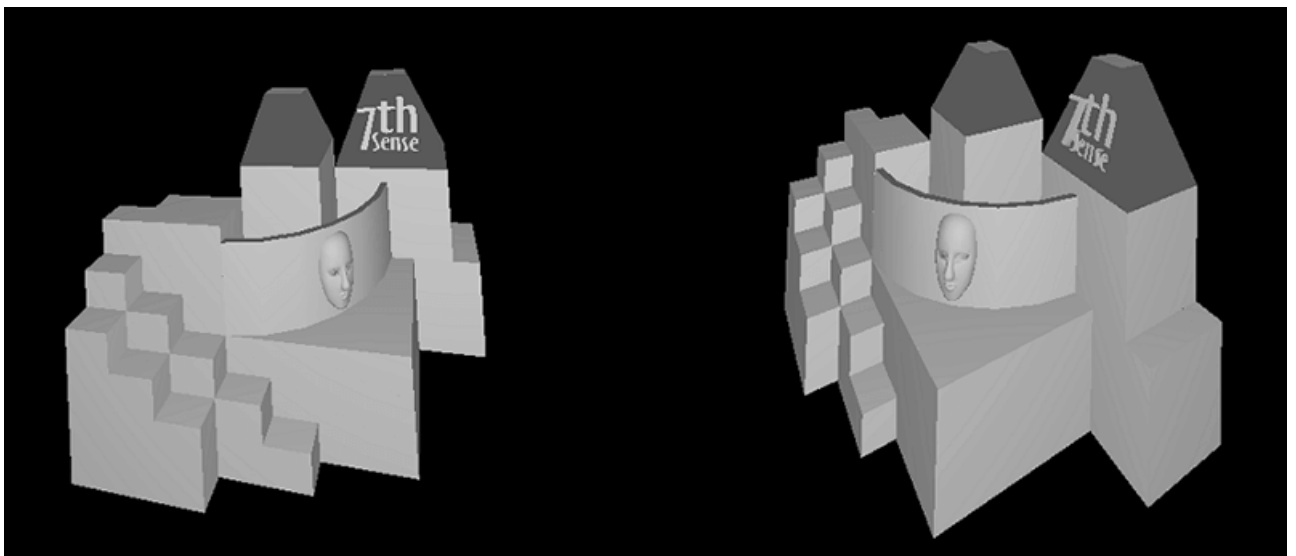

### Eyepoint Selection

In this example (*not a textured mode example*), it is assumed that this eyepoint will apply to all meshes in all channels. Each mesh can have a different viewpoint or more than one viewpoint. Different meshes can share the same viewpoint. Eyepoints are available to all, or selected channels only.

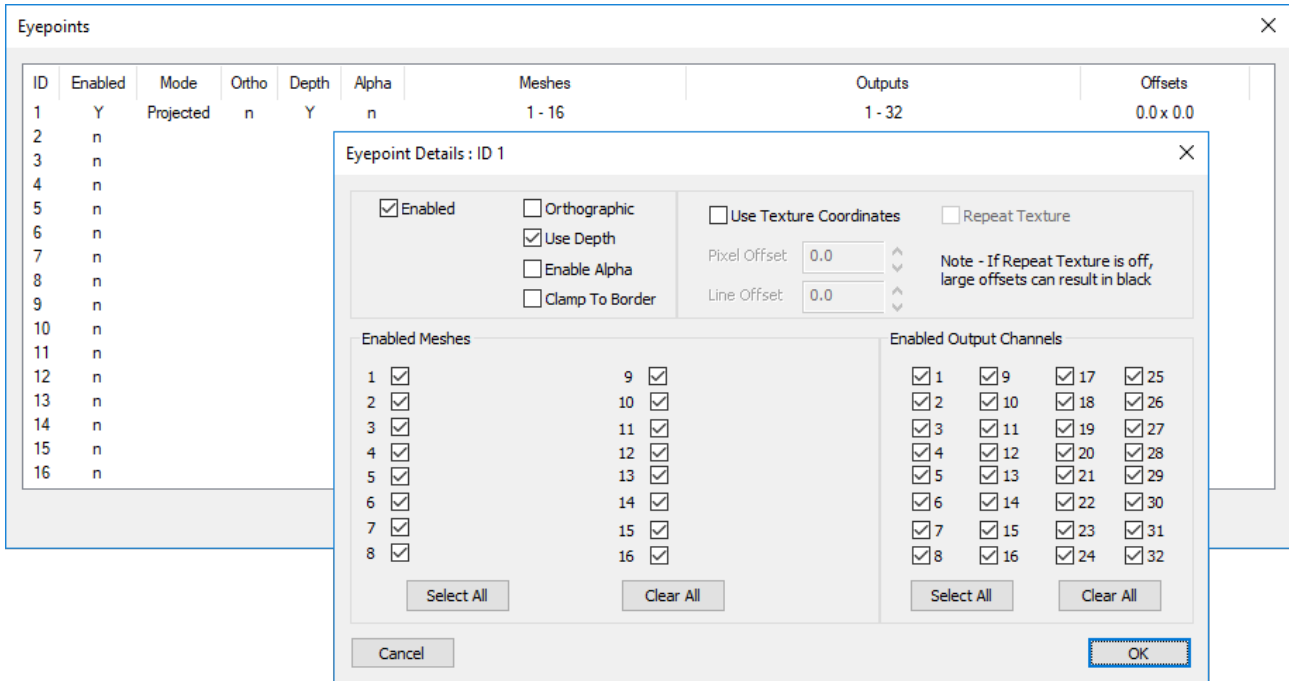

Using texture coordinates with UV-mapped media means that the model, grid, media and object can all be aligned in one calibration operation.

Eyepoints can also be assigned to media by right-clicking the resource on the timeline:

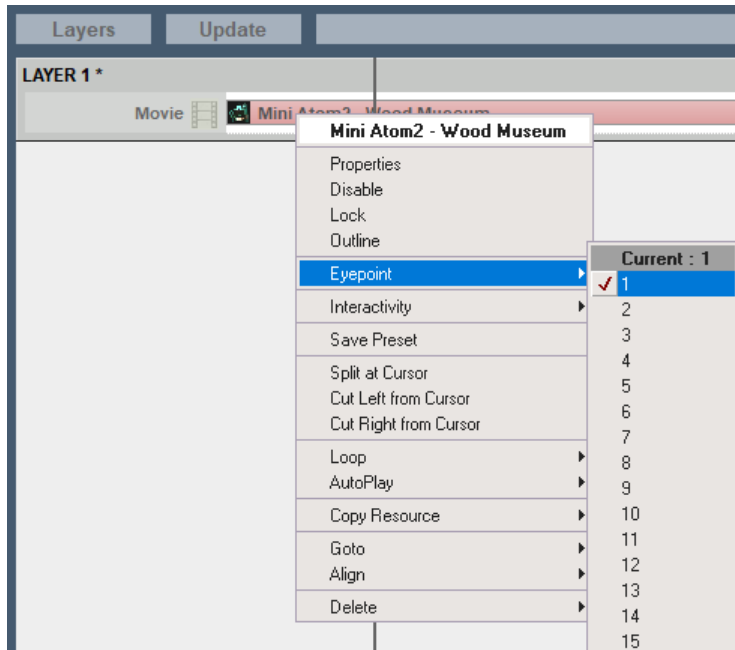
**Enabled:**

Enable or disable this eyepoint. Disabling will hide related meshes.

**Use Texture Coordinates:**

Enable this if the .obj file contains texture coordinates, if you enable this and the model has no texture coordinates, nothing will show on this mesh. Disable this, and the flat plane canvas will be projected from an eyepoint configured in the GUI.

**Use Depth:**

Enable (default) to have occlusion between meshes, disable and the meshes will not occlude against each other (determined by the order shown in the mesh files dialog).

**Orthographic:**

Choose this to have an orthographic (non-lens based) eyepoint, note this only applies to a Projected (non-textured) eyepoint.

**Enabled Meshes:**

Choose the meshes related to this eyepoint.

**Enabled Output channels:**

Choose which output display channels will render this eyepoint.

## 3D Projector Calibration

---

Now that the physical projectors are set up correctly for the media and model eyepoint, the model can be calibrated to the real-life object or canvas. This is done by projecting the mesh using the grid, with its edges and vertices, rather than the media, onto the object. Each channel is calibrated

separately. The media is the same, the mesh is the same, and Delta does all the maths required to adjust for each projector position.

## Per Channel Setup

With the Playback Window in full-screen mode, and DeltaGUI in *Display > Mesh*, with the mesh files set up as above, turn the grid on to 100%. (Grid size: the spacing of the .obj mesh depends on the file itself.) The grid will not show until a channel is calibrated.

If any warps or blends are on the timeline, you will see a red warning, and a checkbox to disable them. This is because the undistorted mesh should normally be added to the real-world canvas, and any warps and blends applied to the media once calibration is complete.

However, since the 3D Calibration process can interpret radial lens distortion from the resulting calibration points, this can now be automatically retrospectively applied to a timeline background flat geometry, for that channel. This can be further warped manually.

- Turn the beams off all but the channel you are calibrating.
- In the Mesh panel, select 3D Projector Calibration view, click the left triangle button (changes from grey to blue) to select 'Use 3D Calibration', and select or ensure your reference mesh (.obj file) for this channel is correctly showing.
- Enter an estimated projector distance for this channel.
- Select Lens Mode.

## Lens Mode

**Current** is the preferred setting for Delta 2.6 users, and further improves reliability. For users upgrading from Delta 2.5 to 2.6, calibrations previously made in **Manual** lens mode will appear as '**Legacy\_1**', and those made in **Default** lens mode, as '**Legacy\_2**'. These two modes can continue to be used to modify the calibrations. For Legacy\_1 and Legacy\_2, see the [Delta 2.5 User Guide](#).

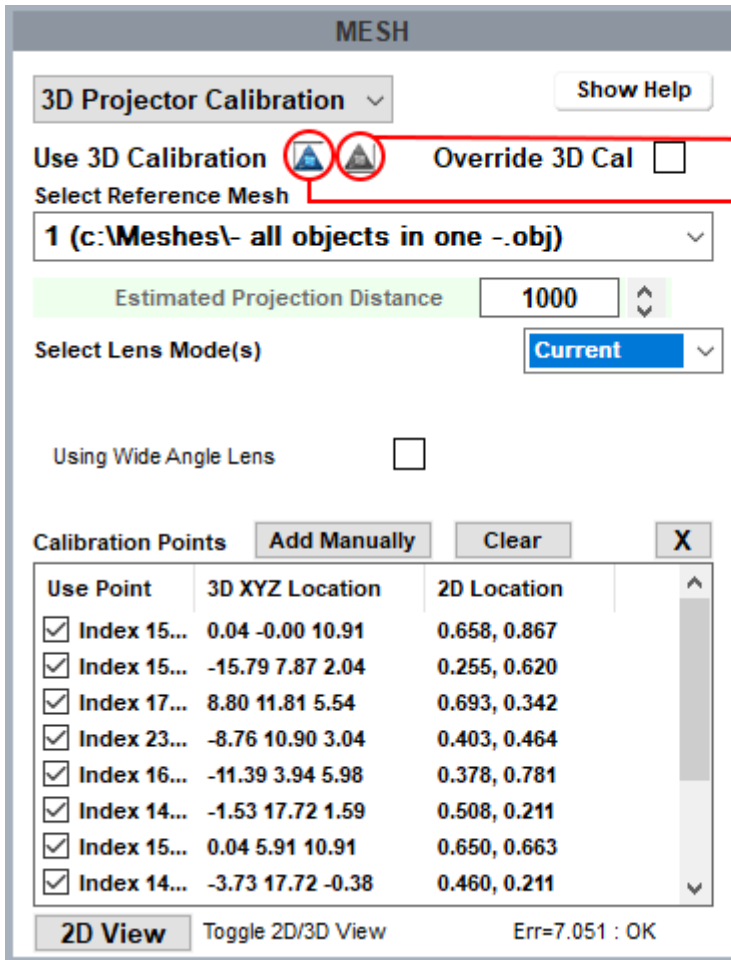

Apply lens distortion

Use 3D Cal

### 2D/3D View

This is the button you will use to toggle between selecting a vertex from the model and placing it precisely on the object. 2D view is looking at the model from the projector position, 3D shows the reference mesh object.

In this playback window view, channel 1 (left) has 'Show all 2D points' applied. Channel 2 (right) is the playback view when selecting an object node in DeltaGUI in '3D View'.

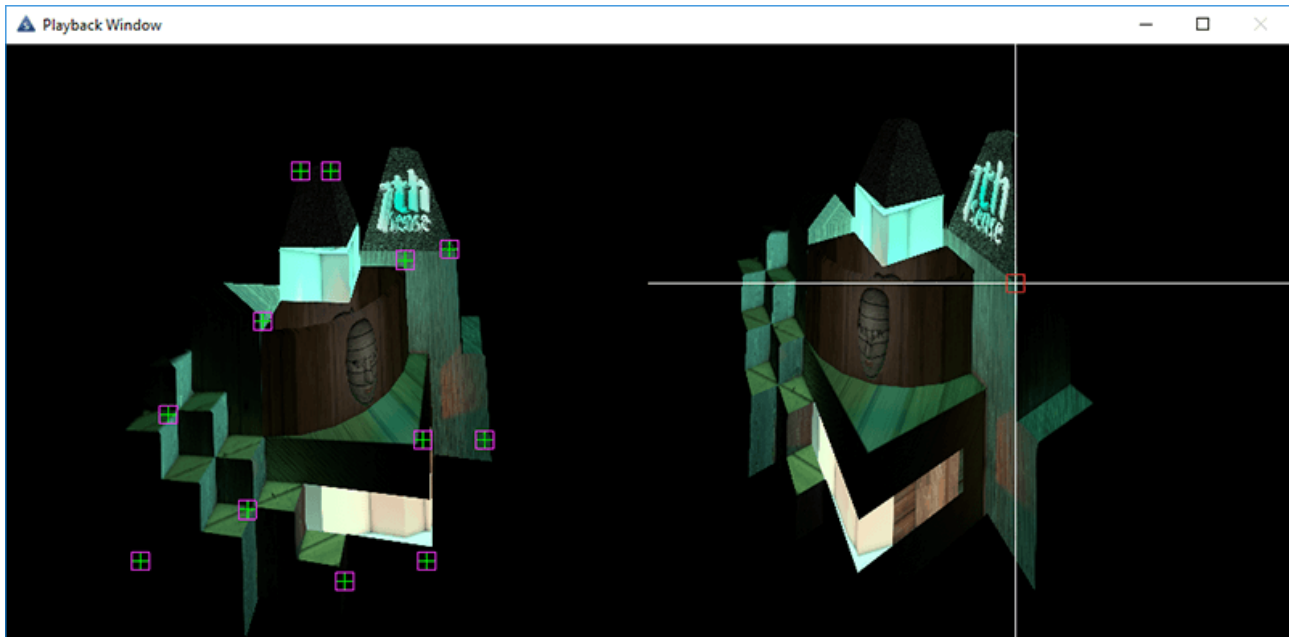

## Calibration Points

Calibration requires at least 6 distinctive and distributed reference points (mesh vertices) to be accurately positioned, using DeltaGUI, on the object. Delta will infer the relative position of all other vertices, which is why a good 3-dimensional spread of calibration points is needed. Delta will then automatically calculate the mapping of the whole .obj mesh onto the object. This initial calibration may be sufficient, but further reference points can be selected and adjusted thereafter.

In 2D view, position the mesh model (this may be out of view, but the RESET button will recentre it). Manipulation of the model using the mouse buttons is the same as shown in Interactive view (shown right). This takes practice, but will be useful in being able to quickly rotate the model for a clear view of the vertices you want to use (rather than a node right behind it).

### Mouse controls:

- **Left-click + drag** : pan and tilt the whole mesh
- **Right-click + drag** : shift the whole mesh
- **Centre-click + drag** : zoom
- **Shift+left + drag** : spin the mesh around a set point in 3D space

**Hint:** in [Mesh Editor view](#) <sup>259</sup>, you can change the size of the dots marking vertices with Node Size . The movement of the mouse can also be adjusted, to control the responsiveness of the mesh image.

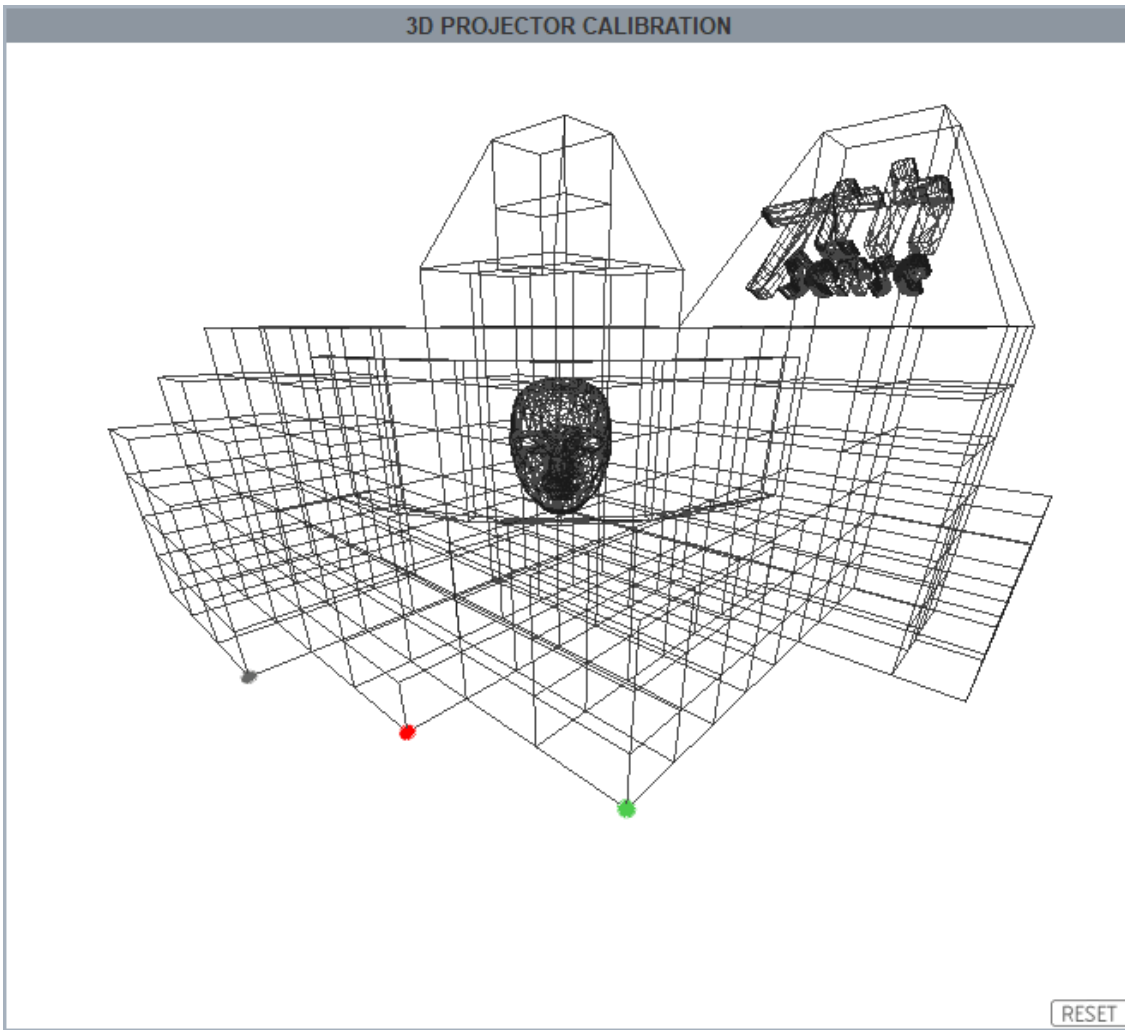

When a node point is found, the dot is grey. When a vertex is selected, it is red. When it has been set, it shows green.

Select a vertex, and switch to 3D view. Now look at the object/canvas and just move the mouse (no buttons) to drag the white cross-hairs in a red box, over the same point in the object:

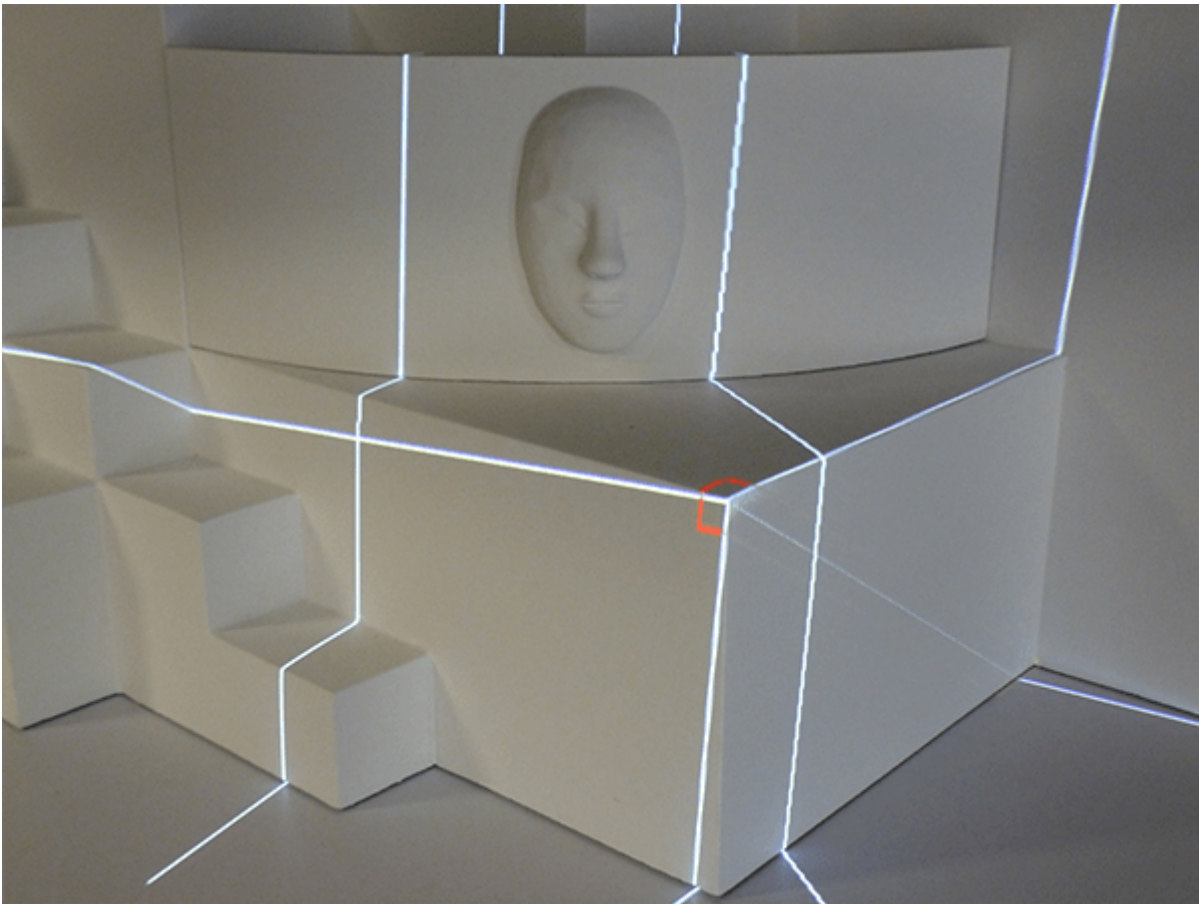

Press **Ctrl + left-click** to register this point, and the lines will turn green. This point will now be listed in DeltaGUI with its 3D XYZ model coordinates and 2D channel-frustum location. **The mouse position need only be approximate:** after registering the point, you can nudge it into more exact position with **Ctrl + arrows** or **Ctrl+Shift+arrows** (fine control). You can choose later not to use it, if for some reason it is not being useful, or you can readjust it by selecting from the list in 3D mode (it will be shown on the object) and nudging it again.



When you have 6 registered points, DeltaGUI will calculate the whole mesh, and the whole grid will be displayed on the object. It should be a reasonably good fit. There are two obvious points here that can be selected to improve the result:

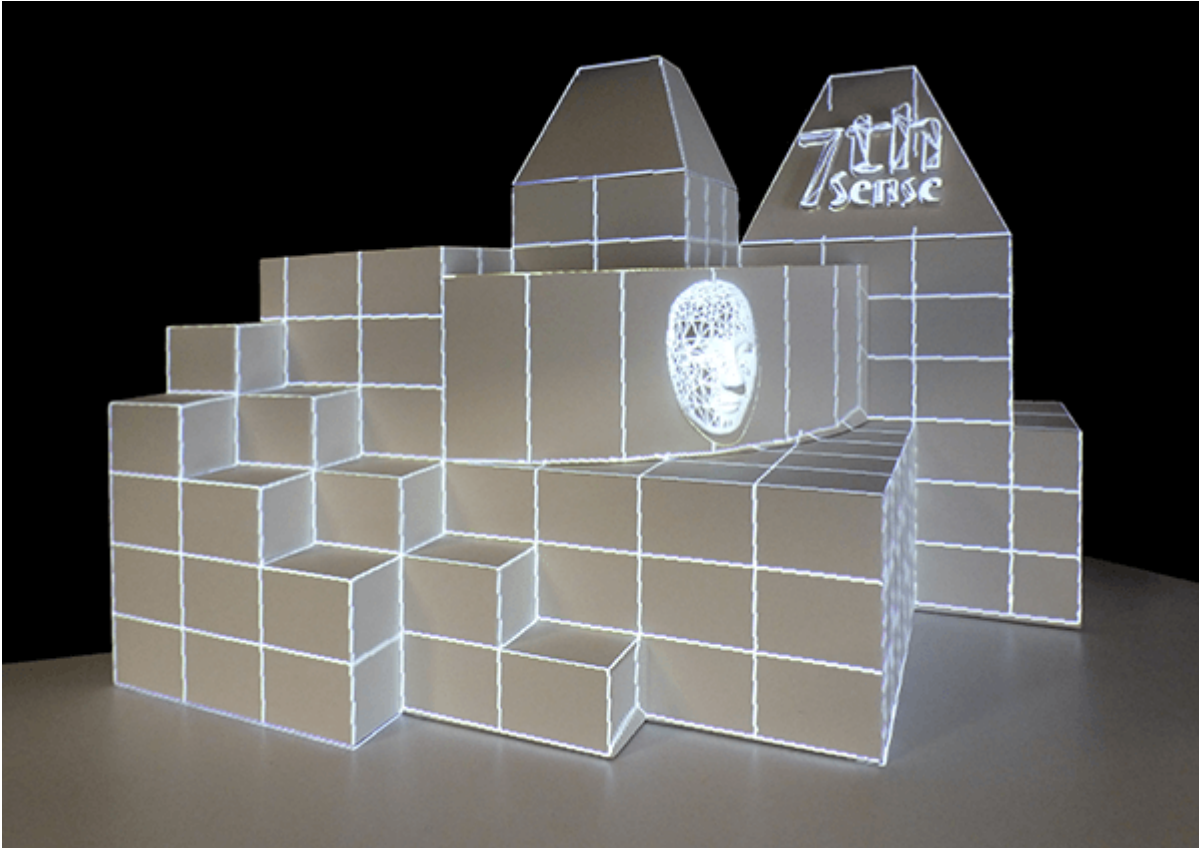

Now look around the other side, which will be covered by the second projector, and we see that it might be better not to include part of the mesh here at all:

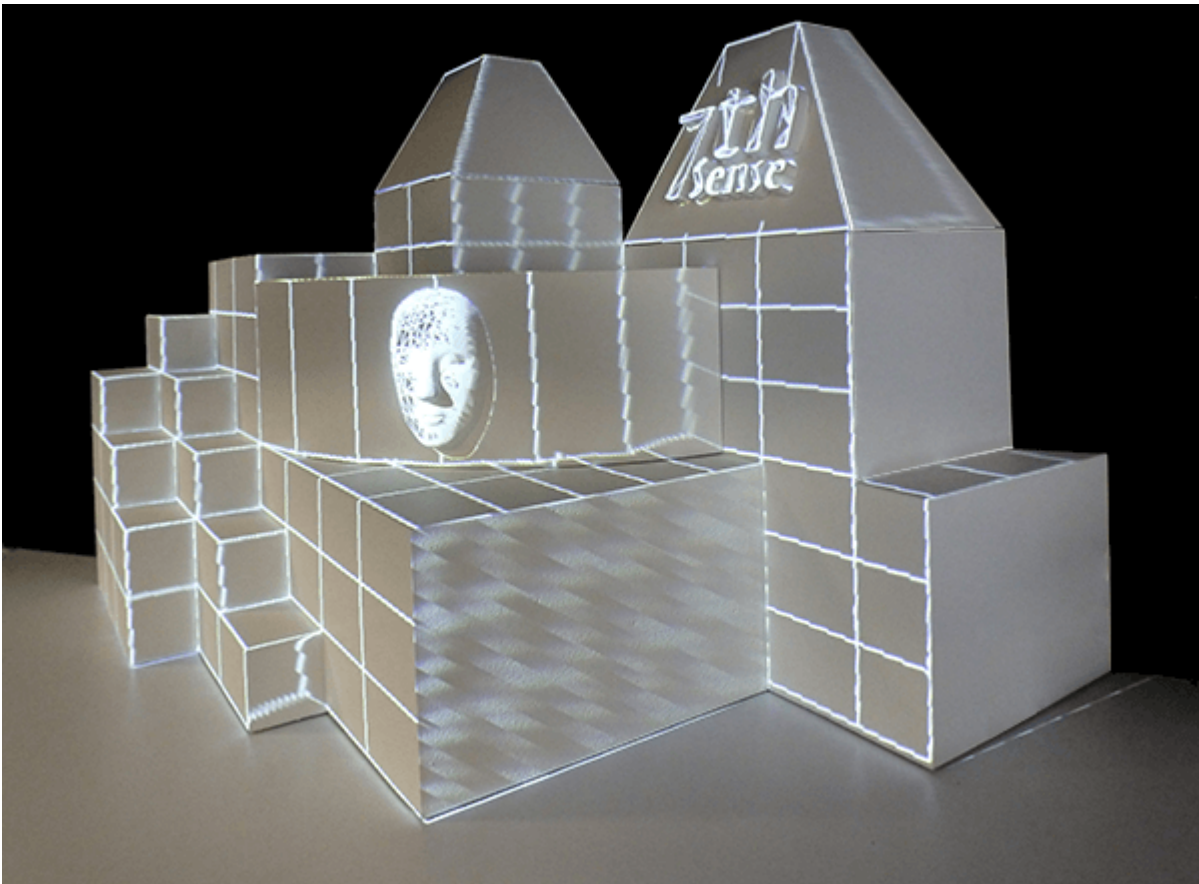

We can calibrate the second projector now, and return to the [mesh editor](#) <sup>(259)</sup> later to tidy up, and to hide or fade these faces per channel.

Here is one completed channel in DeltaGUI:

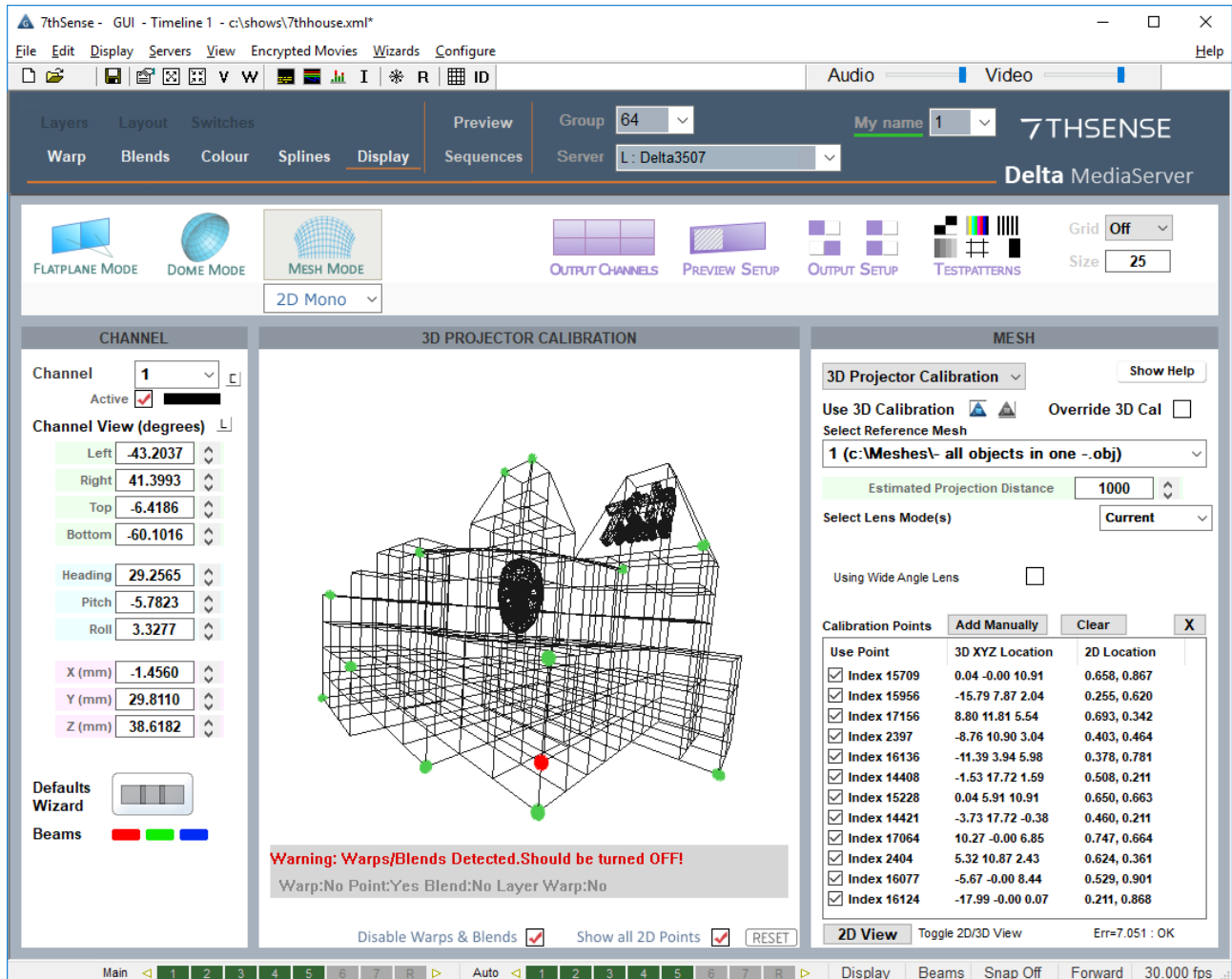

## Editing Calibration Points

To **adjust** any point, select it in the list (make sure you don't deselect it in the checkbox) in 3D mode, and it will show a red box around the vertex on the object. Nudge it into a better position with **Ctrl+arrows** or **Ctrl+Shift+arrows** (fine control).

**Clear:** If you want to start over, click 'Clear'.

: Delete a selected point only.

**Add Manually:** If you have precise calibration points available from tracking software such as BlackTrax, these can be added manually:

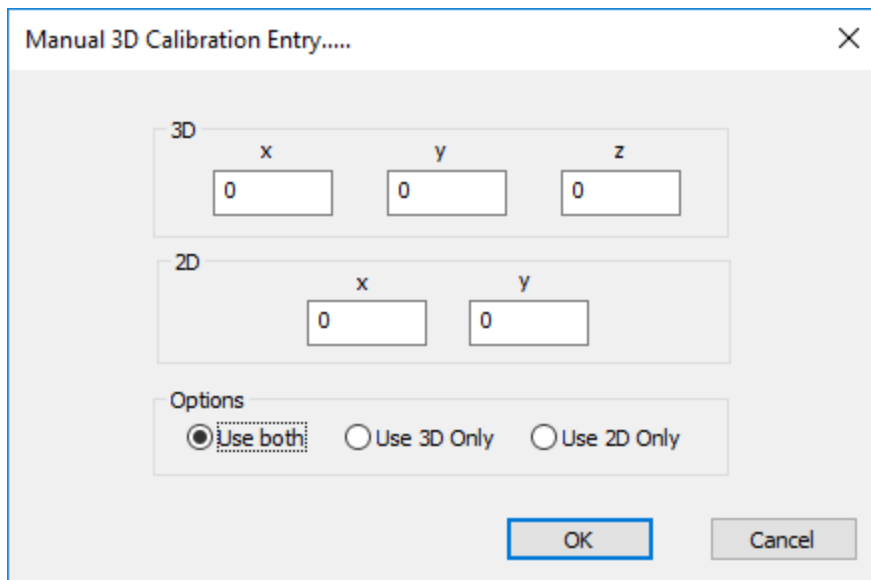

The image shows a dialog box titled "Manual 3D Calibration Entry....." with a close button (X) in the top right corner. The dialog is divided into three sections:

- 3D:** A section with three input fields labeled "x", "y", and "z", each containing the value "0".
- 2D:** A section with two input fields labeled "x" and "y", each containing the value "0".
- Options:** A section with three radio buttons: "Use both" (which is selected), "Use 3D Only", and "Use 2D Only".

At the bottom of the dialog, there are two buttons: "OK" and "Cancel".

## Viewing the Result

Now take the grid display off, and go back to DeltaGUI > *Layers* and add or enable your media in the Timeline, and your media should fit the object. UV-mapped media is baked into the .obj model, but flat-projected media may take additional adjustment for a perfect fit.

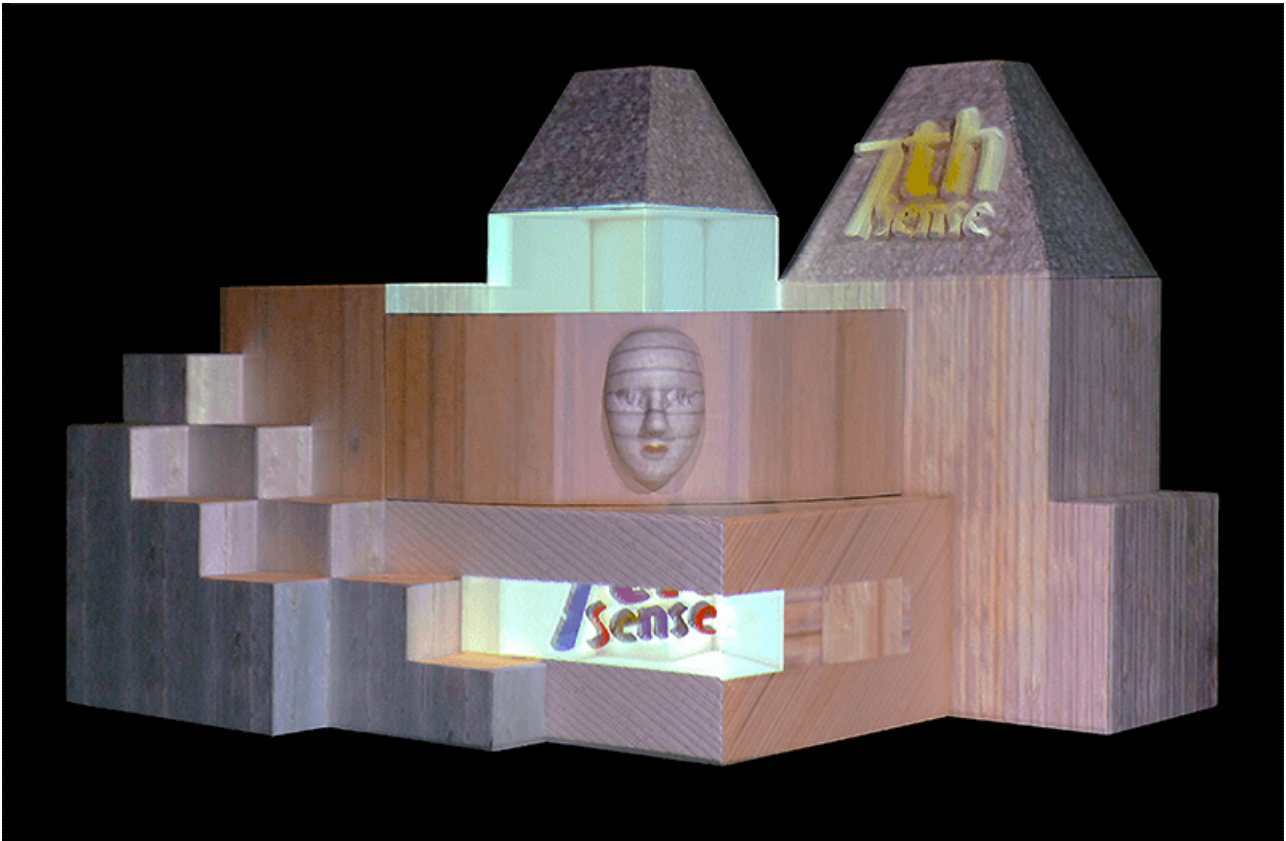

## Warping a Mesh

---

It may be useful to warp the **mesh as a whole**, rather than manipulating the mesh .obj or the canvas, especially if it just involves regular or geometric deformation. Timeline media warps are normally disabled during calibration, but can be added and adjusted afterwards.

### From Delta 2.6.48

The warp must be applied to the background layer, and can be applied to a channel or to a mesh. Multiple background warps can be applied to separate meshes and channels. (Selecting the type changes the number selector descriptor.)

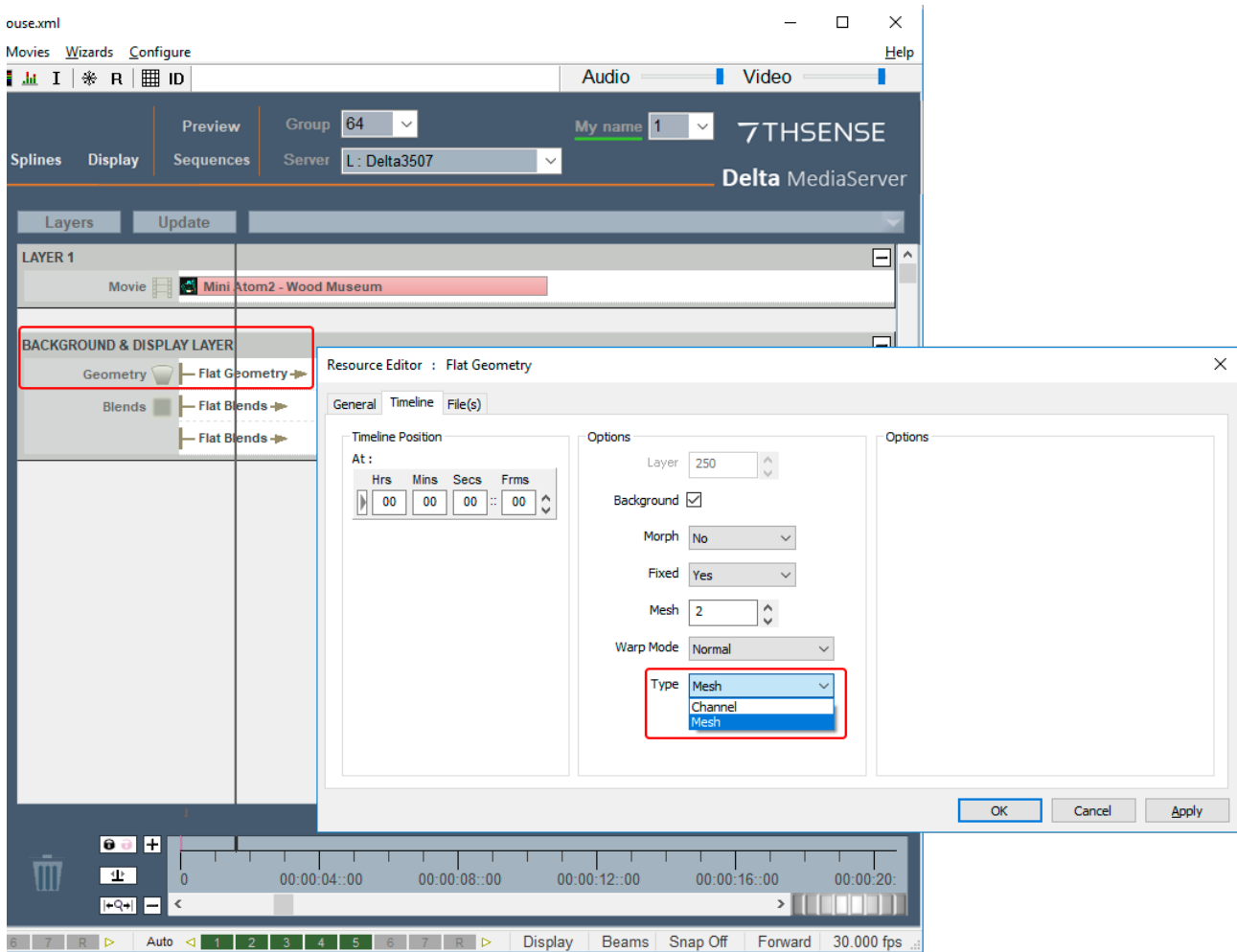

## Earlier versions: Delta 2.6.1 to 2.6.47

The warp must be applied to the background layer, and not the media channel but the respective mesh. Delta will allow one or two meshes to have background warps applied:

- to apply a warp to the first mesh (ID=1), assign it to channel 17
- to apply a warp to the second mesh (ID=2), assign it to channel 18

**Note:** these are not 'active' channels.

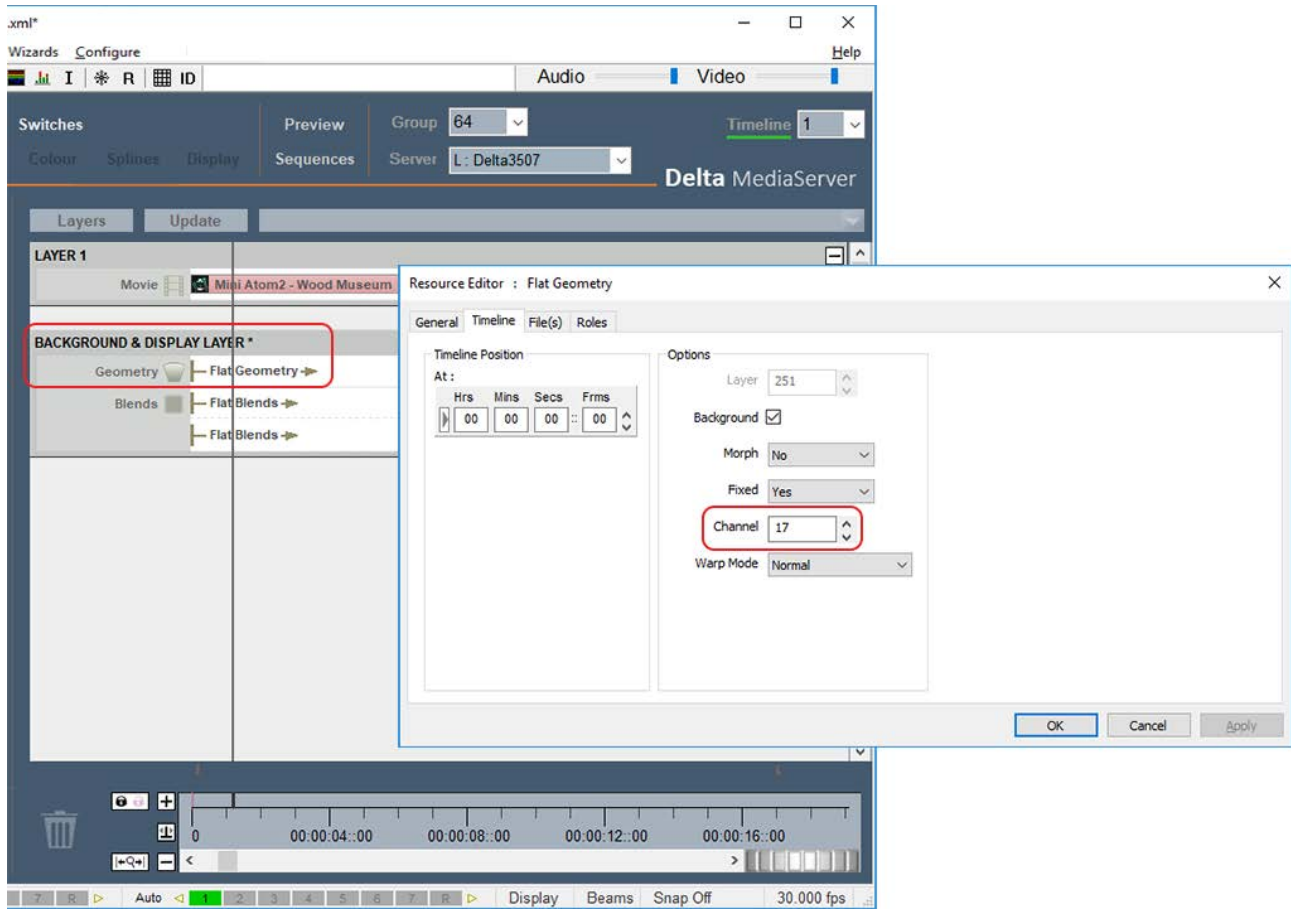

## Blending in Mesh Mode

In mesh mode, flat blends offer an additional choice. The Resource Editor for flat blends placed on the timeline (background layer) have this additional tab of settings:

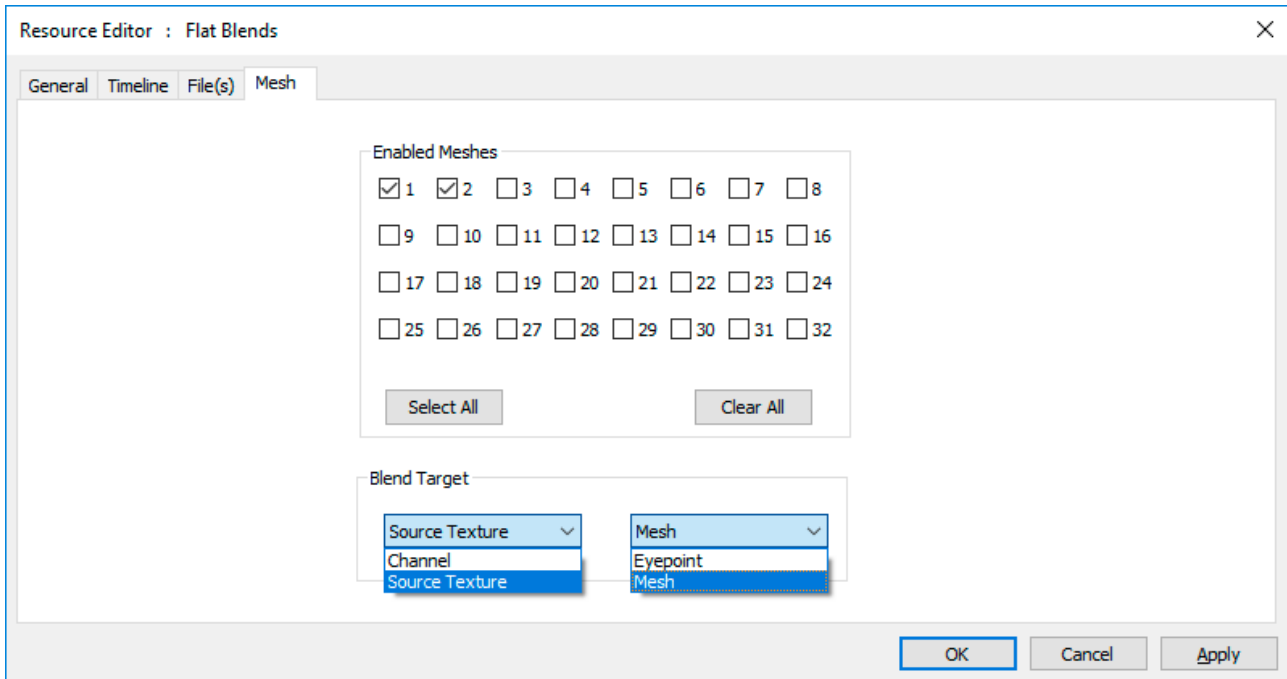

### Blend Target

In projected mode, the blend can be restricted to not only channel (also in the Timeline tab) but particular eyepoints, and with the choice of where it applies. 'Channel' will apply it as normal to the periphery of the projector frustum, 'Source Texture' will apply it to the periphery of the media frame.

In textured mode the blend target should be 'Channel'.

Enable target mesh(es) and Eyepoint(s) as required.

This is similar to being able to warp the canvas, or to apply warps to media.

## Troubleshooting Projection Mode

### Fitting the Mesh

If, having positioned six calibration points, the whole projected grid is very wrong, this could be either due to poor distribution of points or a mistaken vertex between the mesh and real life (perhaps behind the one you think it is).

- Try switching off individual calibration points in case one in particular is bad.



- Try adding one further point, perhaps where the projected grid is most out of position.
- Check the Lens Modes in the 3D Projector Calibration panel. Are you using the recommended defaults? Try unchecking and checking Fixed Aspect, Zero Tangential, and K6, K5, K4 for best improvement.
- Discrepancies between the mesh and the real life surface can also be corrected for by [editing points on the mesh](#) <sup>(259)</sup>.

## Fitting the Media

Delta works out how the projectors fit the model to reality. If the media designer has worked from the same model and scale, and rendered it correctly, *and* you have compensated for irregularities in the real-life canvas, then the single crucial error may be setting the eyepoint position in Delta, so check this carefully first.

- If the eyepoint is correct, some warping of the canvas may be appropriate. Add a flat geometry to the background layer, assign the channel in the Resource Editor, and use channel point distortion warp (see this section under Display Configuration, in the Delta User Guide).
- If the overall correction required seems geometric, try warping the mesh as a whole (see [Warping in Mesh Mode](#) <sup>(245)</sup>).
- If the mesh and media correspond and the required adjustment is small, then the **media** can also be surface warped into a better fit. Place a flat geometry on the timeline in the same layer as your media. Go to Warp and ease the media into place. Remember that Surface Warp has two different interpolation methods. Spline method moves points in smooth arcs, warping a greater area than the linear method, which moves the point(s) in straight lines, within its own area, without affecting the rest of the image. The H+, H-, V+ and V- buttons increase the grid density (click then 'Apply' or Enter), which affects the area of warping.

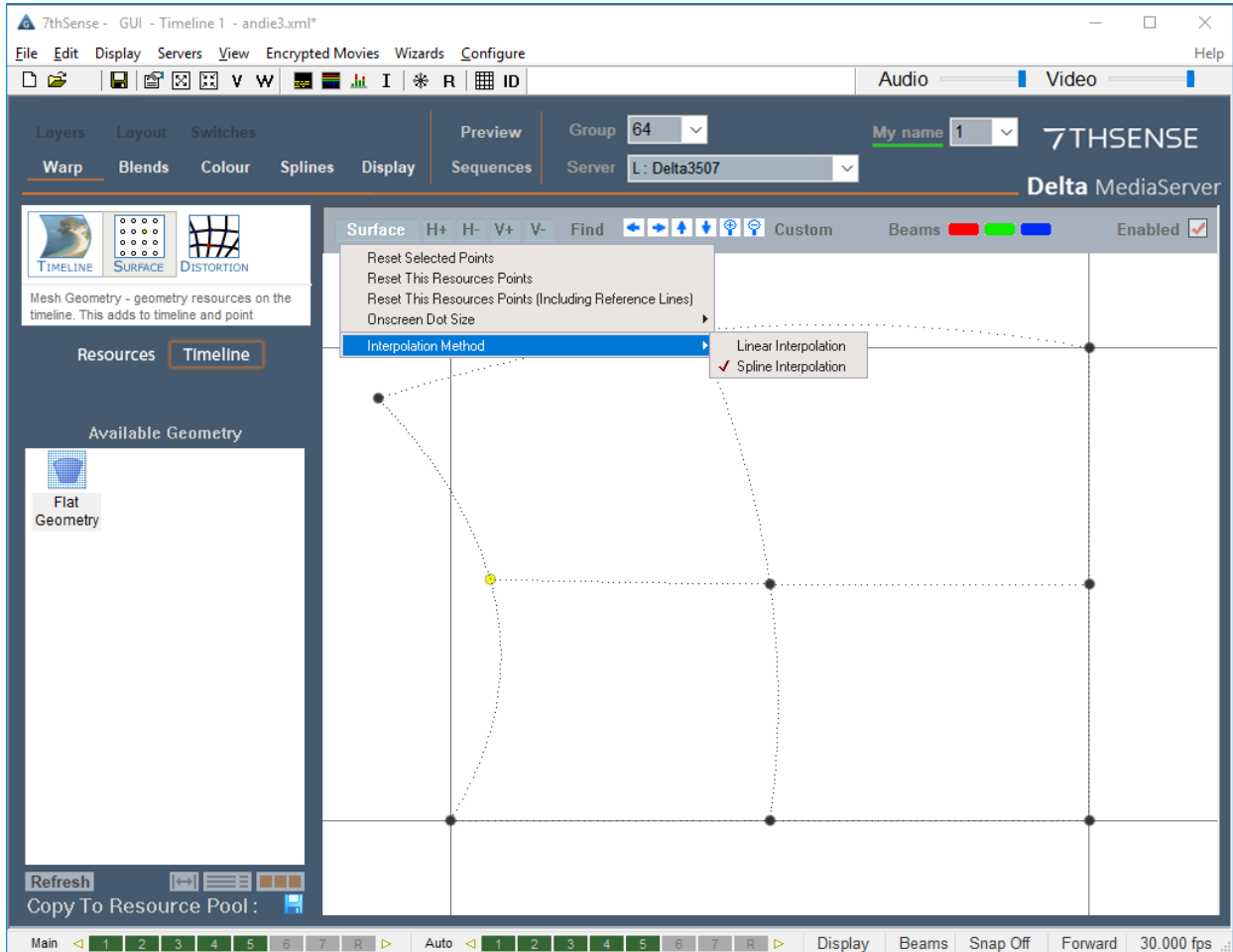

For more guidance on surface warp, see this section under Display Configuration, in the Delta User Guide.

## Mesh is Clipped or not Showing on Playback

If on playback (projected, displayed or in the Playback window) you either cannot see all your mesh, or cannot see it at all, it could be out of range of the DeltaServer clipping plane settings. This could occur for very large or distant meshes, which you would not notice in DeltaGUI whose clipping planes are separate.

The DeltaServer far clipping plane is held in a Registry key and can be adjusted.

## Registry Edits

7thSense software uses the Windows Registry extensively, and on occasion we make recommendations for changes.

- Before making any changes, close DeltaGUI and DeltaServer.
- DeltaServer can take up to 10 seconds to fully close in the background, even if it appears that all the Windows have closed. Ensure that Delta has *fully* closed before opening and/or refreshing, and finally editing. The best way to ensure this, is to watch Windows Task Manager > Details list. You will see 'DeltaServer.exe' in this list if DeltaServer is still running. If it won't close for any reason, you can right click on it in the list and choose 'End Process Tree'.
- Make a note of any setting before you change it, in case you want to change it back.
- Only make the changes as recommended and only to those registry keys.

Go to Windows search > regedit >

Computer\HKEY\_LOCAL\_MACHINE\SOFTWARE\7thSense\Delta\Graphics and find FarClip. The default is 10000 and can be increased as required.

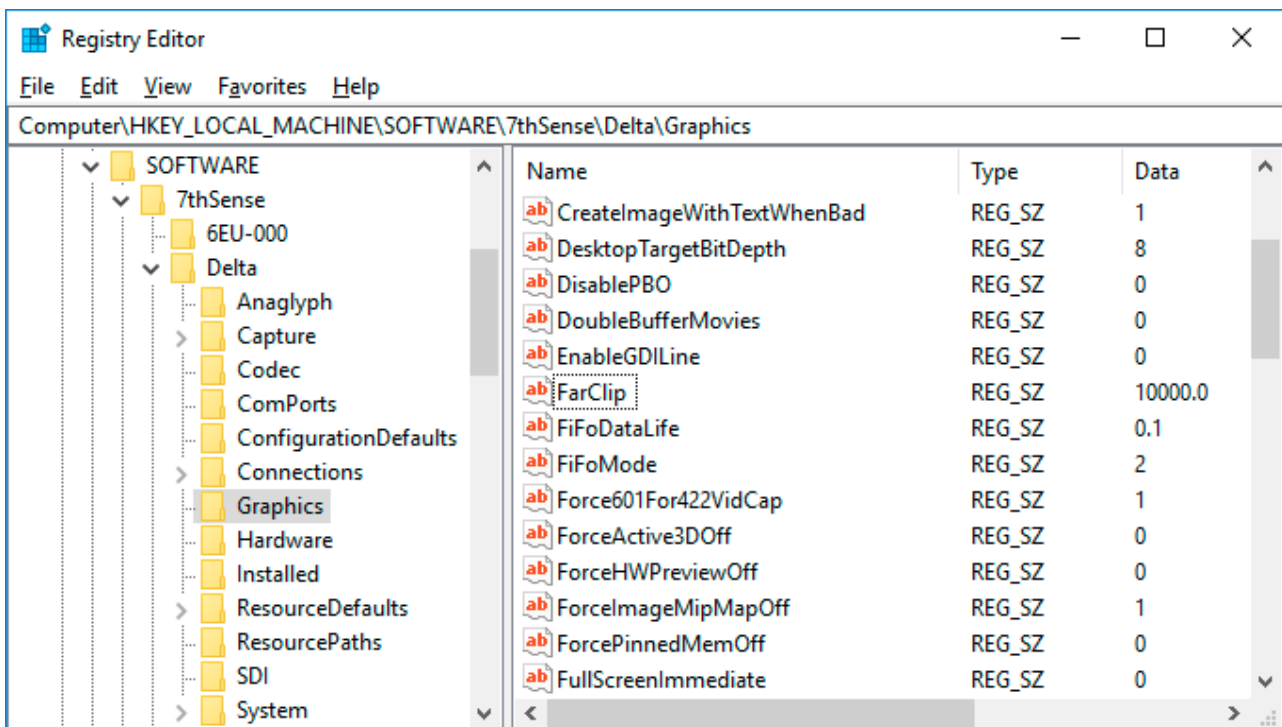

Note that the far clip should be set to just beyond the model limits to preserve rendering precision in the 0 – FarClip range.

## Working in Textured Mode

Working in textured mode is little different, but since there is no single eyepoint, parameters need not be added. When assigning an eyepoint for each channel in *Display > Mesh Mode > Mesh > Eyepoint Files > Eyepoint Details*, make sure you are using texture coordinates:

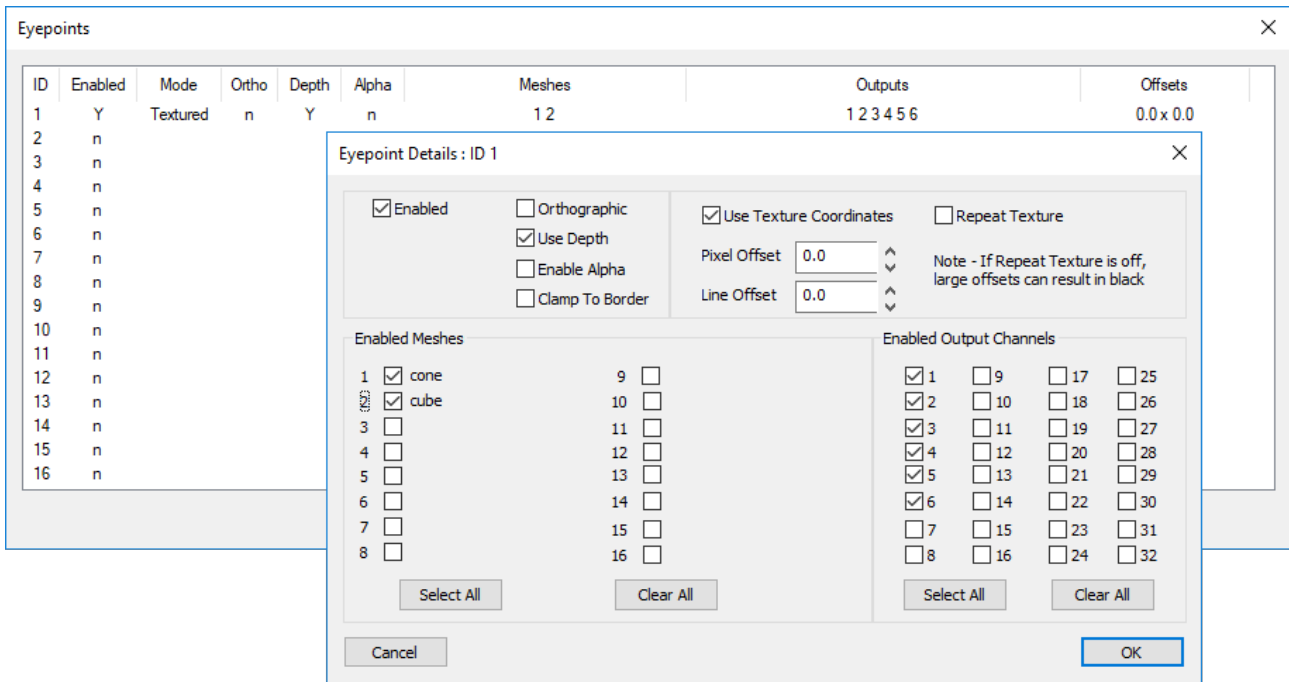

## Multiple Meshes and Media

Delta can manage up to 32 meshes (16 prior to version 2.6.48). Since in mesh mode, media can be associated with specific eyepoints, and eyepoints can be associated with specific meshes, we can have simultaneous media on a timeline, to be projected onto separate objects using their own meshes. Here we have two images, and have assigned them to different eyepoints by disabling all others:

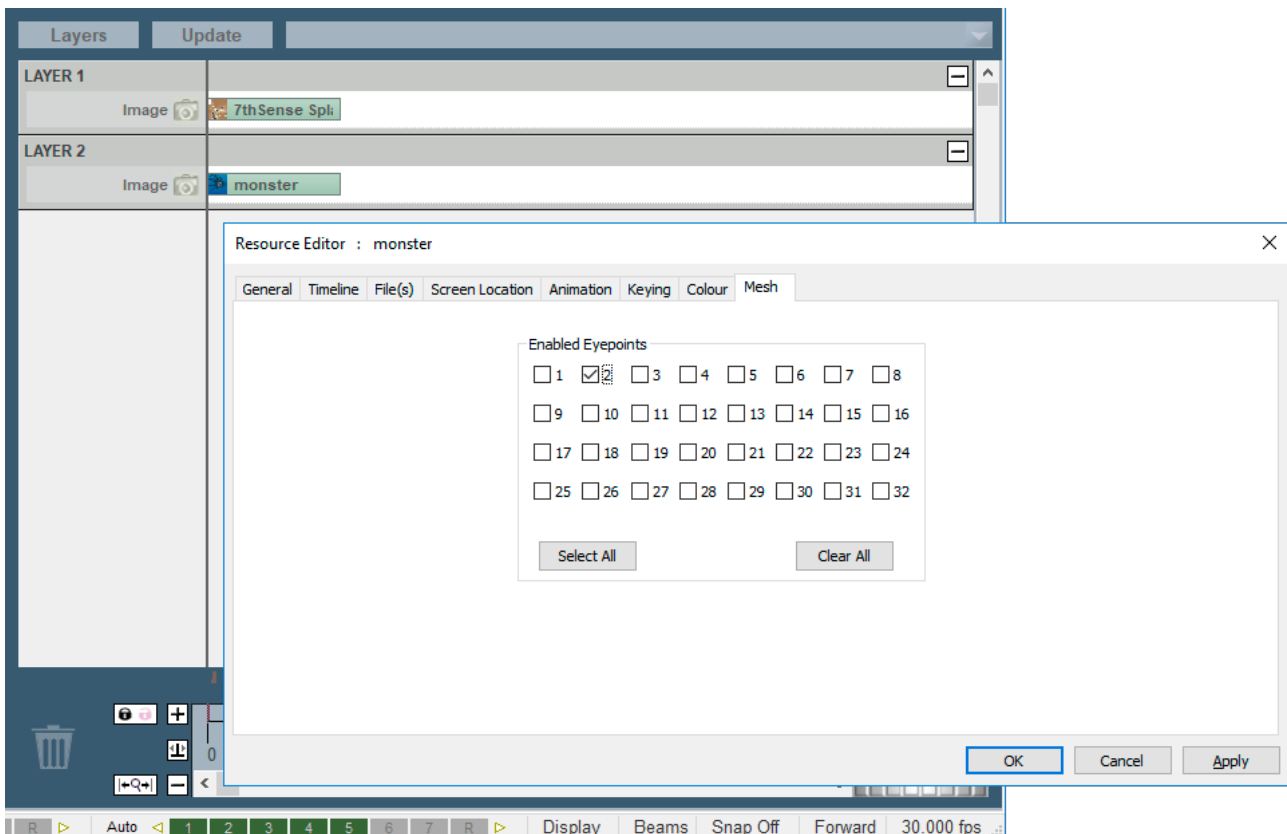

Here we have two meshes, for a tube and a cube, set up in DeltaGUI, with different eyepoints assigned to them:

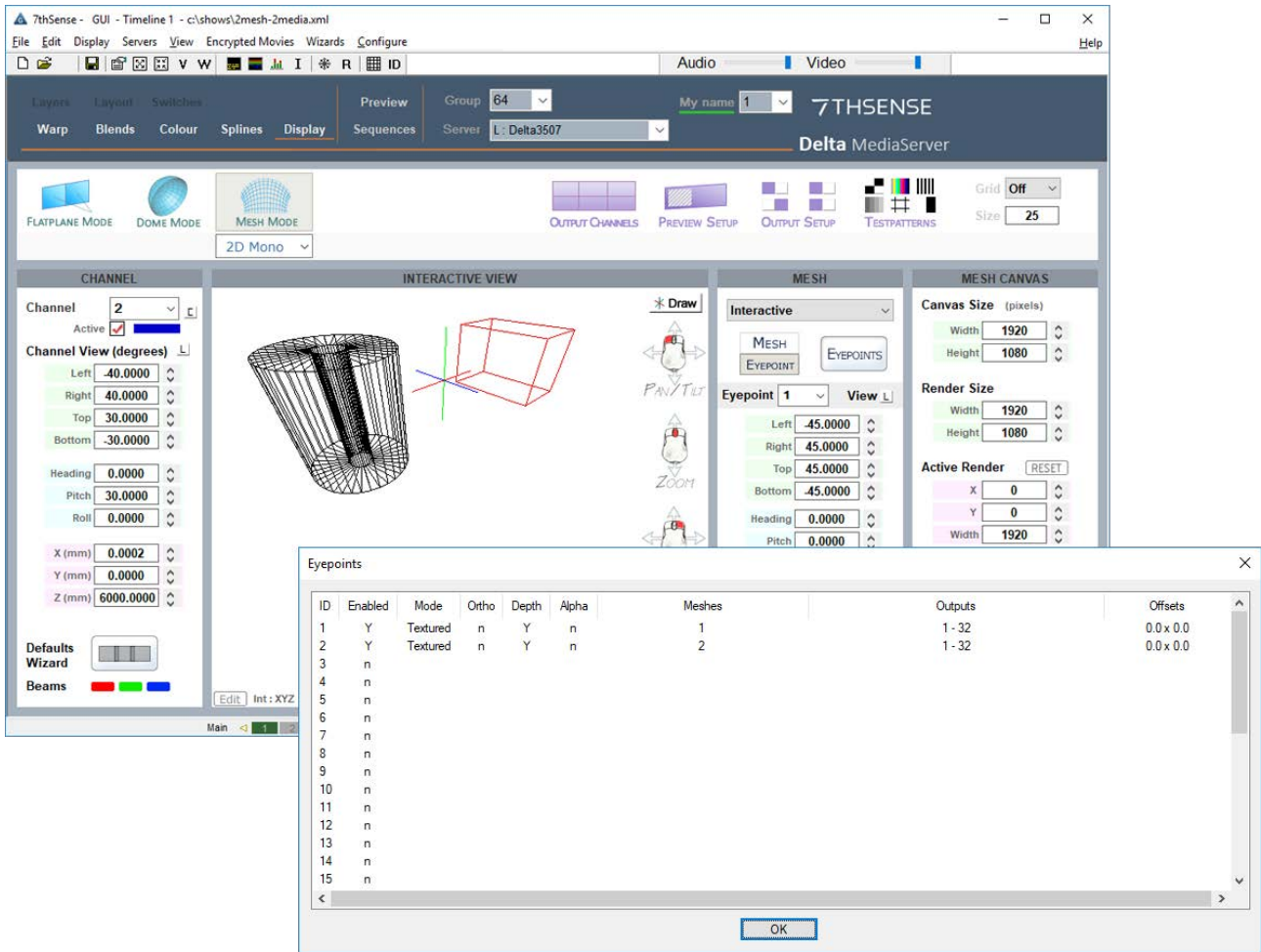

Here in Playback we have media 1, associated with eyepoint 1, which is associated with mesh 1 (the cube), and media 2, associated with eyepoint 2, which is associated with mesh 2 (the tube):

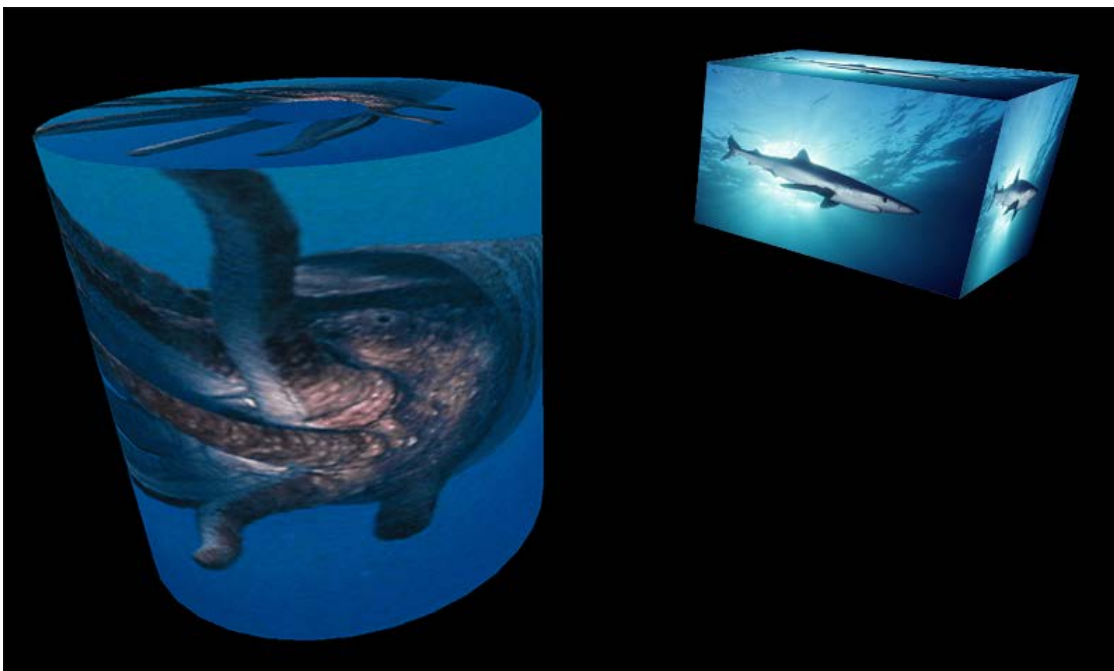

Note that the media eyepoints are using textured coordinates.

## Active 3D Mesh Mode

In Active 3D for mesh mode, two copies of a mesh, each with respective left or right eyepoint, are required.

Paired left- and right-eye media are played to separate channels (e.g. 1, 3, 5 and 7 for the left eye, and 2, 4, 6 and 8 for the right eye). By linking eyes, the same warp and blend is applied to both left eye (odd number) and right eye (even number) channels. Mesh files and their eyepoints are assigned to the respective left and right eye media running on the timeline.

Here is the workflow to achieve this.

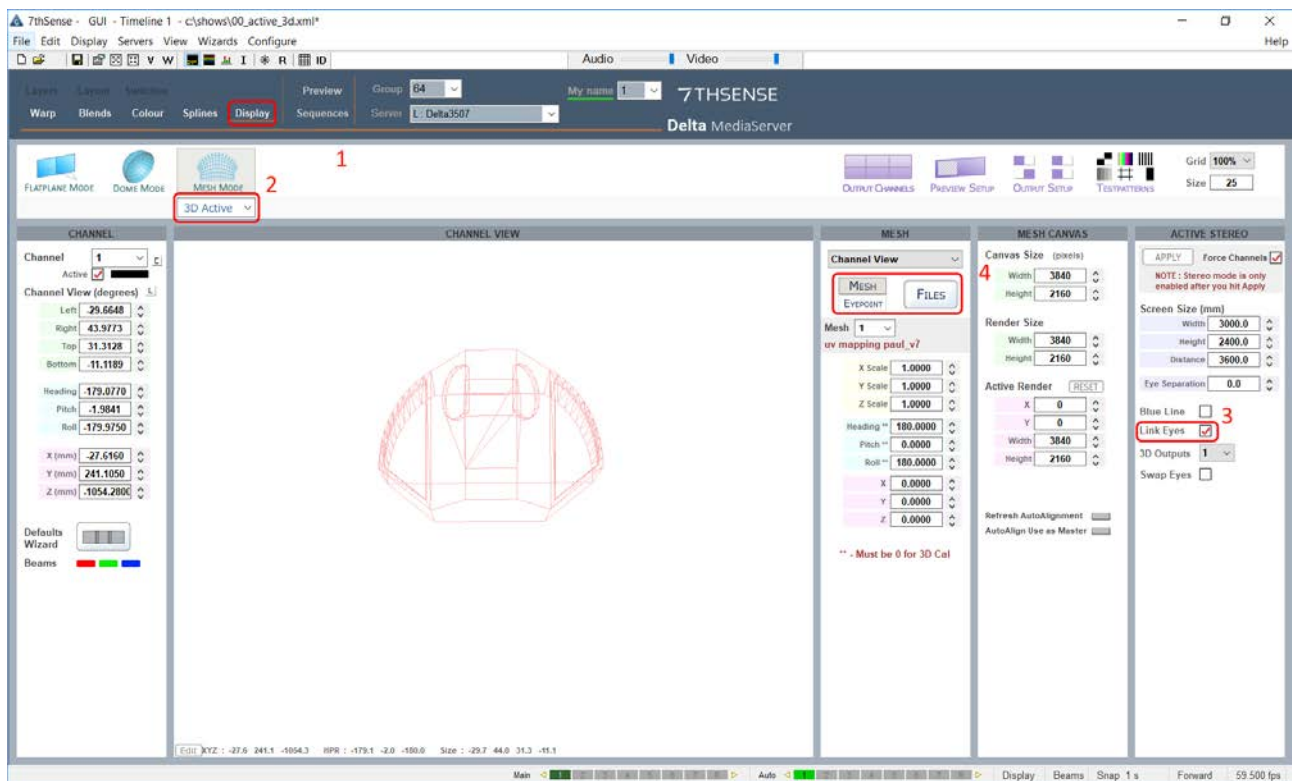

In DeltaGUI, Display workspace (1), select Mesh mode and 3D Active (2). Link Eyes (3) to link any warp and blends applied to left-eye channels also to right-eye channels.

### Mesh Files

Now add the left and right mesh files of your model or surface.

Click on the Files button (4) and in the new dialog, double-click on the first ID row. Use the browse button to locate the left-eye mesh file you want to use. Do the same for row 2 to add the right-eye mesh file.

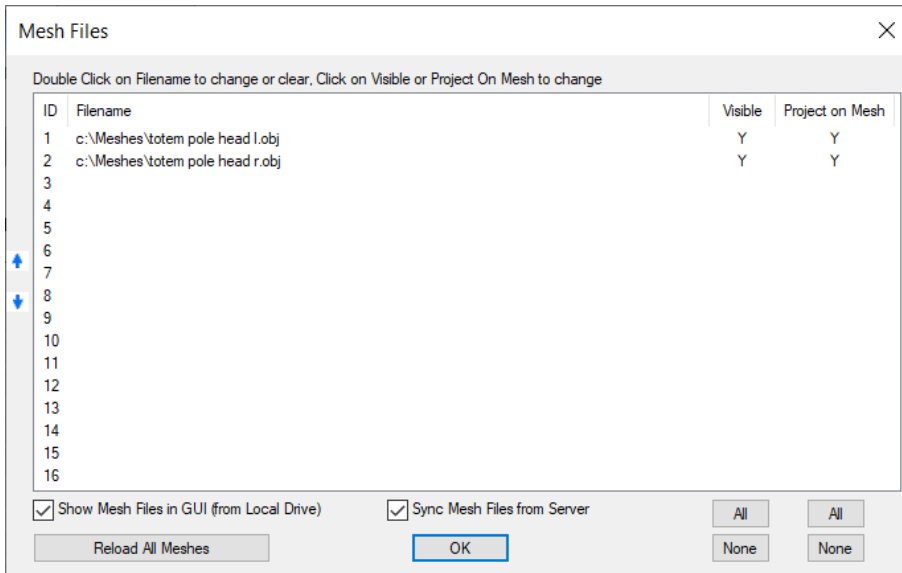

Click 'OK' to close the dialog.

## Eyepoints

Select 'Eyepoints' below 'Mesh', and then the 'Files' button again (as marked (4) above).

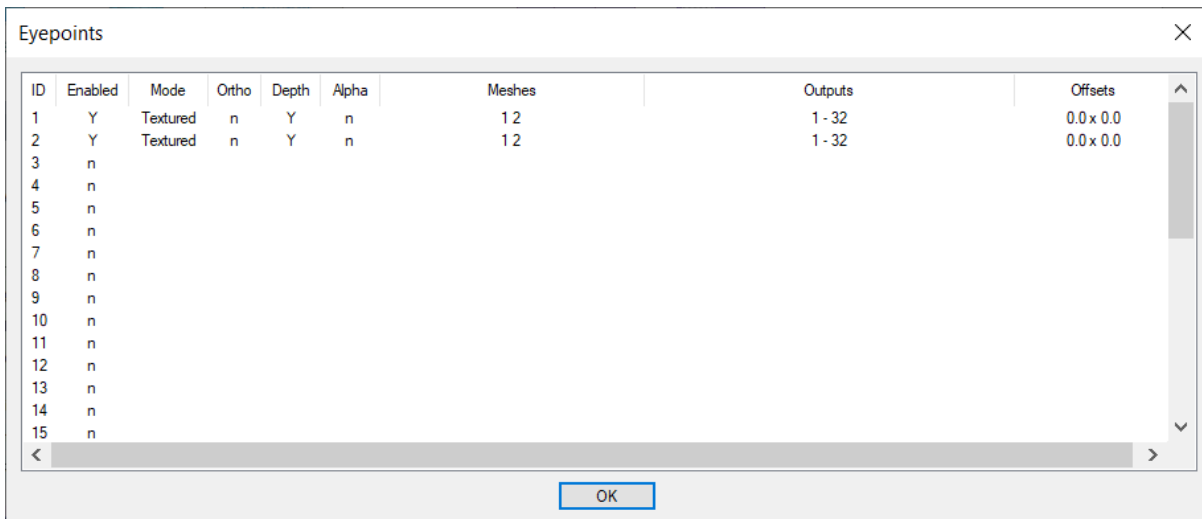

Double-click the row for eyepoint 1 (left mesh), and in the new dialog (below), 'Clear All' meshes, and enable just mesh 1. Then under 'Enable Output Channels', click 'Clear All' and check just the odd numbered channels in the required range (in the example, for an 8-channel, 4-pair setup):



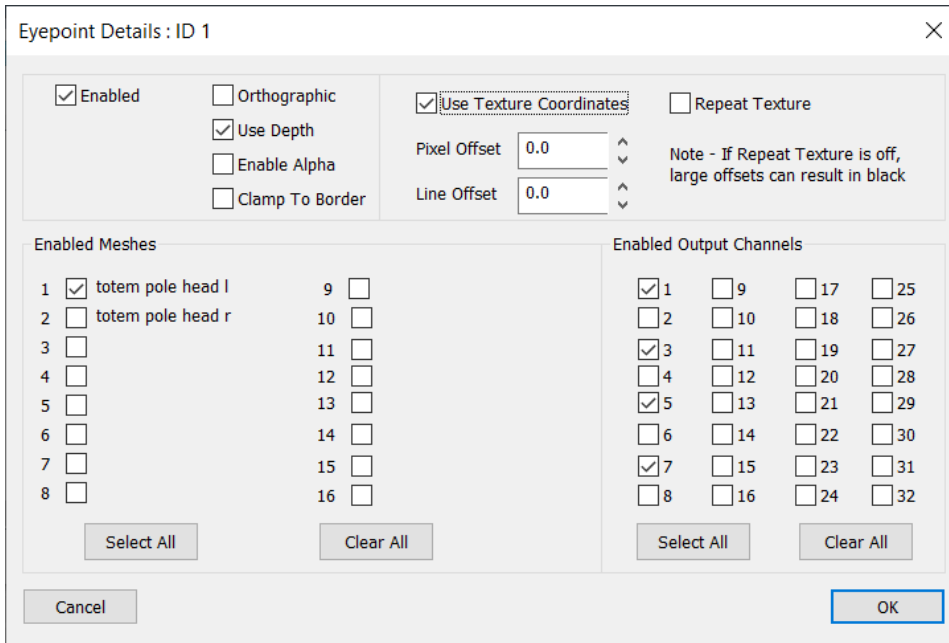

Click 'OK' to close, and this time select eyepoint row 2. Select only mesh 2 and apply only the even numbered channels in the required range:

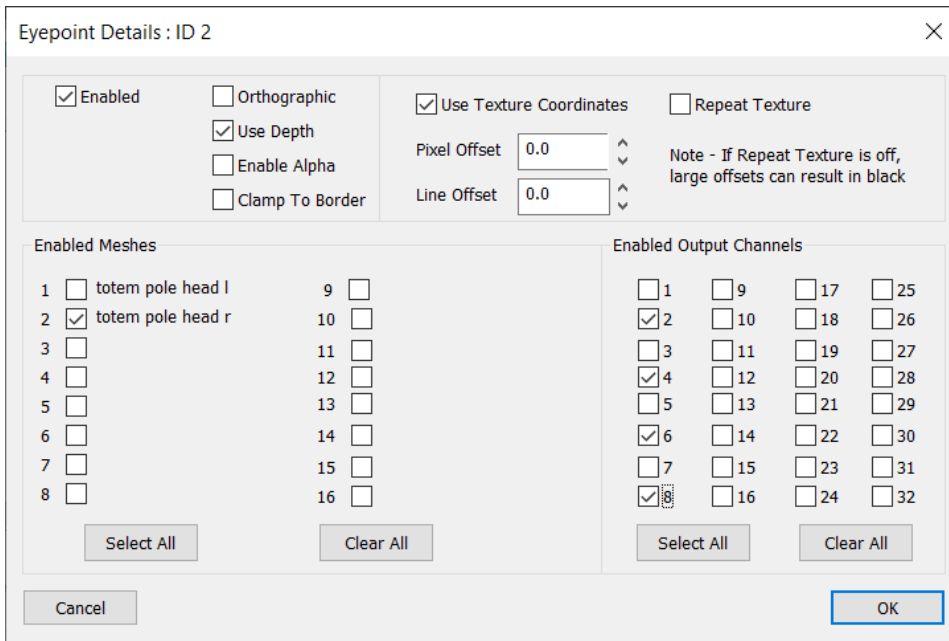

For the left eye media on the timeline, double click to open the resource editor, select the 'Mesh' tab, clear all eyepoints and enable only eyepoint 1:

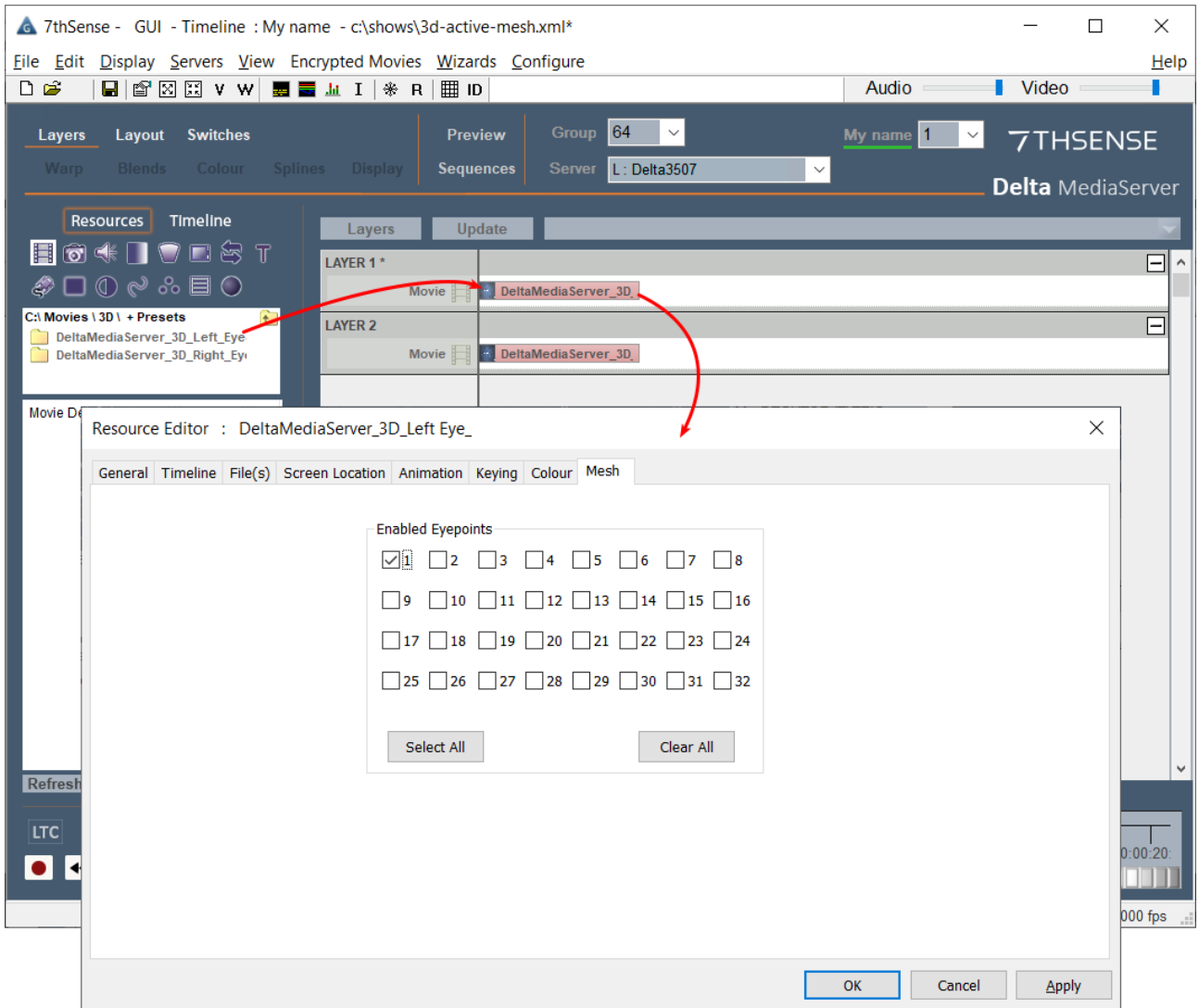

For the right eye media, open the resource editor, clear all eyepoints and enable only eyepoint 2:

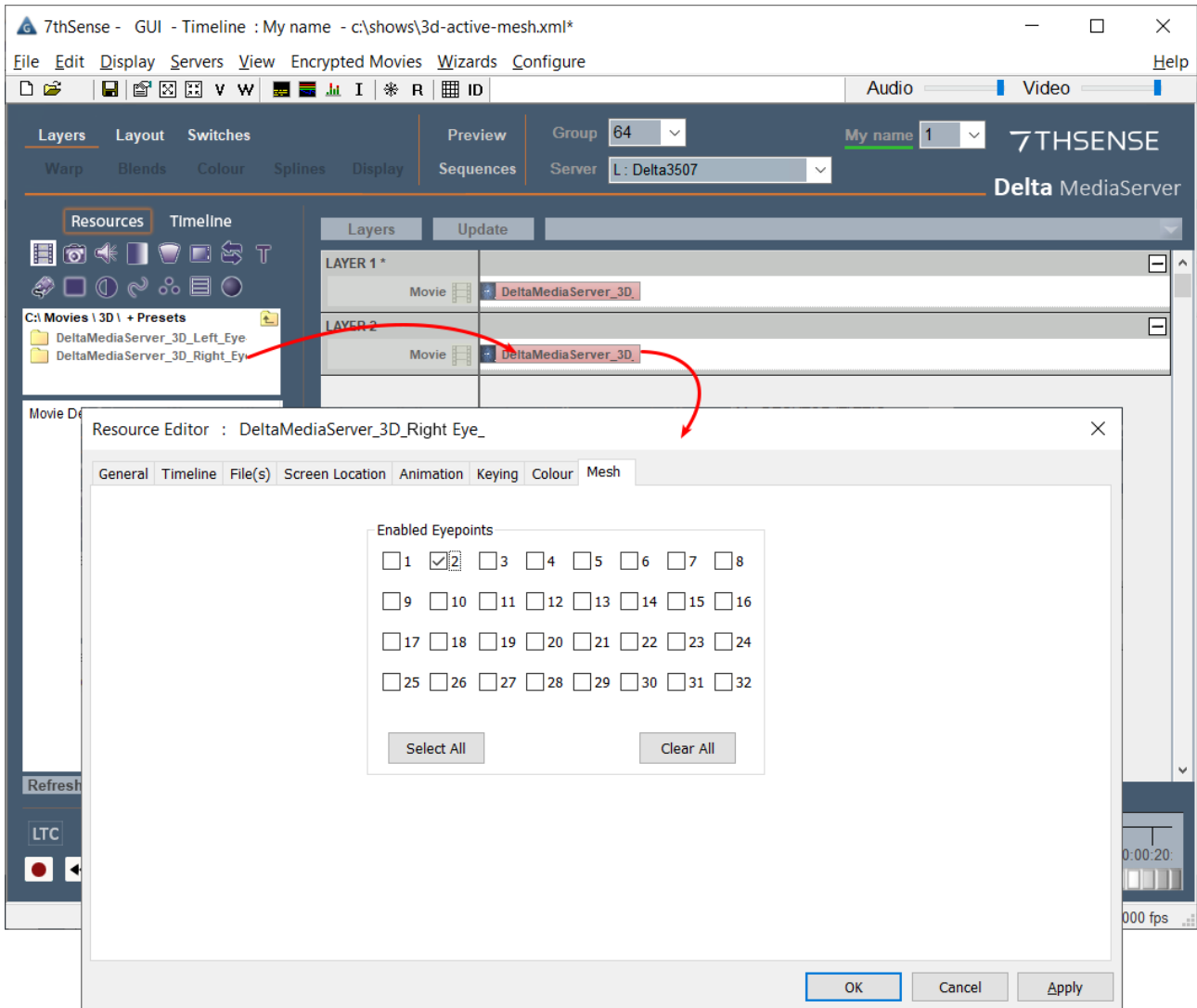

## Editing a Mesh

The Mesh Editor allows you to manipulate the mesh as a whole, per channel, by vertex or group of vertices, with control over the editing view. **The X, Y, Z axes throughout are those based on the .obj model's origin.**

Even if you are not editing points, the mesh editor has settings for moving the mesh around in the GUI, with slider controls for Node Size and Mouse movement size.

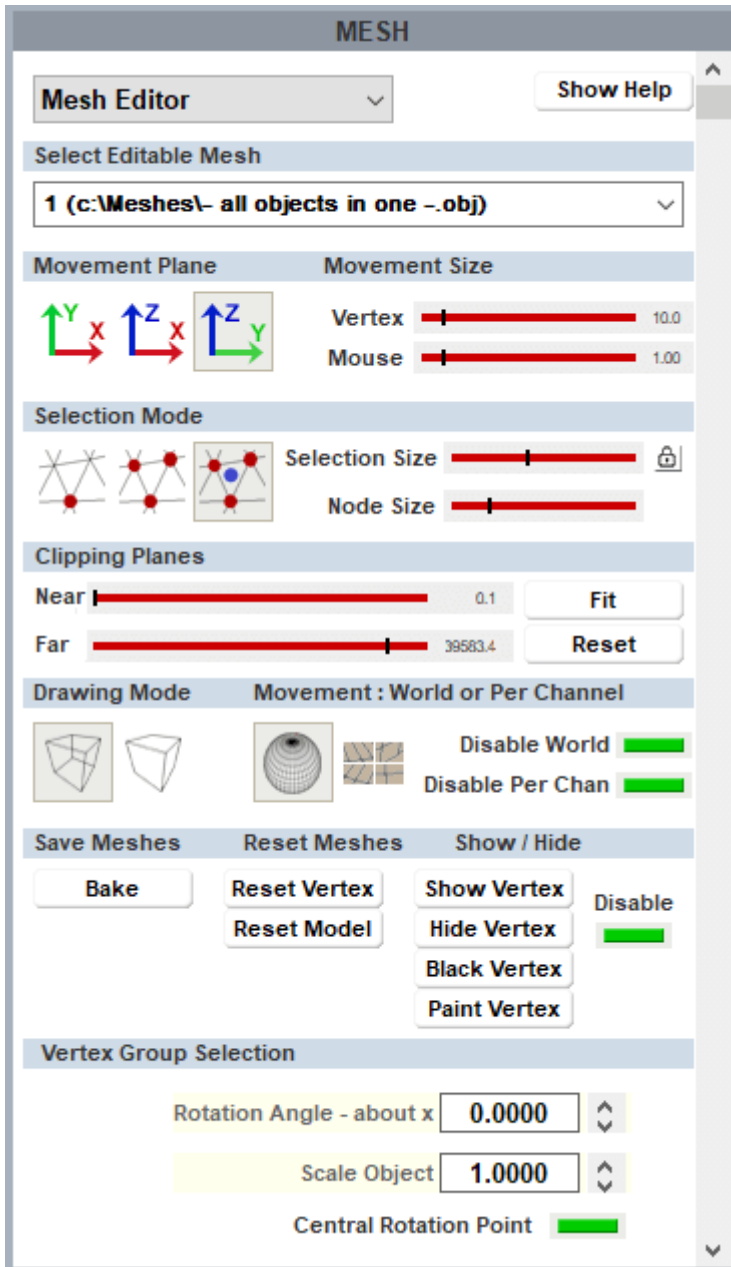

**Movement Plane**

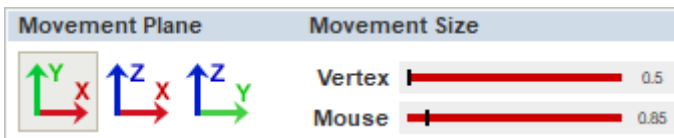

Select which 2D plane (axis pair) in which you want to move selected vertices, in the overall 3D space.

**Movement Size**

The **Vertex** slider controls sensitivity of selected vertex movement, using Ctrl+arrows. The **Mouse** slider controls the speed at which the mouse drags the mesh around in the GUI.

### Drawing Mode



These options enable you to see the entire mesh, or focus on the foreground only. The result will depend in part on the way the mesh has been constructed.

### Movement: World or Per Channel

Choose whether you want to manipulate the mesh for a particular channel only, or for all channels (World view). Per channel is generally best for small adjustments, and World if there is a significant error in the media across the whole object. These edits are overlaid on the .obj mesh and will be saved as separate .vto files. The Disable buttons switch the adjustment overlays off and on without resetting the model.

### Selection Mode

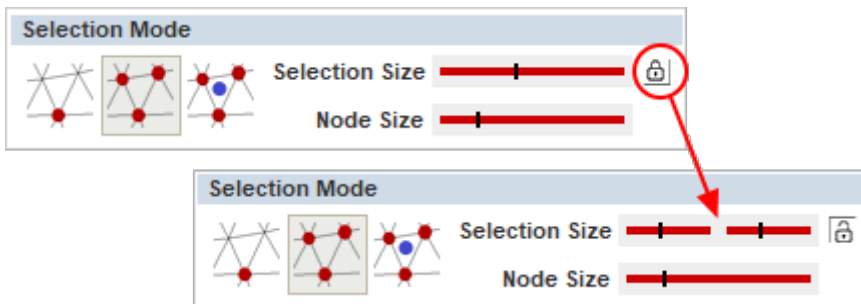

Vertices can be selected either to reposition them, or to change their visibility (as in the oblique faces of our object example above). Select a single vertex to move it, or a group of vertices, or where a set of linked vertices has been constructed in the .obj file, select the group.

The group selection area finds all vertices within an XY window *as seen from the current viewpoint in the GUI, not relative to the size of the obj mesh*. The size of this window can be controlled by the size slider. Click the **lock** button for separate X and Y axis sizes. *Selection includes all vertices in this rectangle, in all planes*. Add more vertices to the group selection with **Ctrl+left click**. Near or far vertices can be excluded by working in a clipping plane (see below). For multiple selection of individual vertices, use a very small group area.

*In this example:* red points are a selected group with equal XY selection. Green shows the mouse hovering over another group with a limited X axis and mid-range Y (see settings on the right).

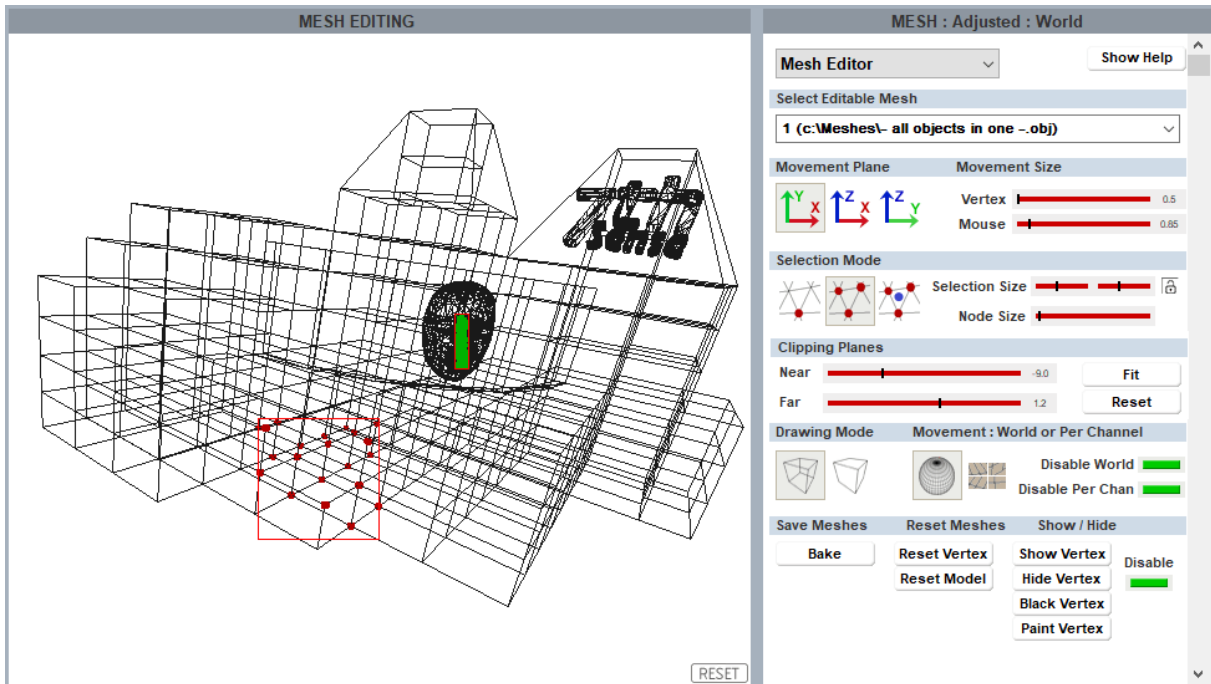

**Moving points:** Once selected, all red nodes can be moved around *en bloc* using **Ctrl+arrows**. For finer movement, use **Ctrl+Shift+arrows**. Movement is along the X, Y, Z axes of the .obj file, based on the object origin. Selected vertices or the whole model can be reset using the **Reset** buttons (bottom right).

## Moving nodes around

Whenever groups of connected nodes are moved, this inevitably distorts the surrounding mesh. A mesh that is not an accurate representation of the real world can, to some degree, be pulled into position, but there are limits beyond which making one part fit makes another worse.

## Vertex Groups

In complex models it is helpful to construct the .obj file out of groups of vertices where the groups are not connected directly to each other: for example, the detailed face illustrated above is separable. In these circumstances, the separable section of linked vertices can be selected by use of the third mesh selector in Delta (the one with the blue dot): the 'vertex group selection'. The separable part can now be manipulated, to move it, or rotate it on any axis about a selected point, or its median point.

In the illustration below, the face element from the front of the building has been selected with a single click because it forms a vertex group, unconnected to the main building. Lateral movement is as elsewhere using Ctrl+arrows, or Ctrl+Shift+arrows (finer) according to the movement size set in the editor panel, and the selected movement plane axes.

**Please note** that depending on the complexity of the vertex group being manipulated, this can be very demanding of DeltaGUI.

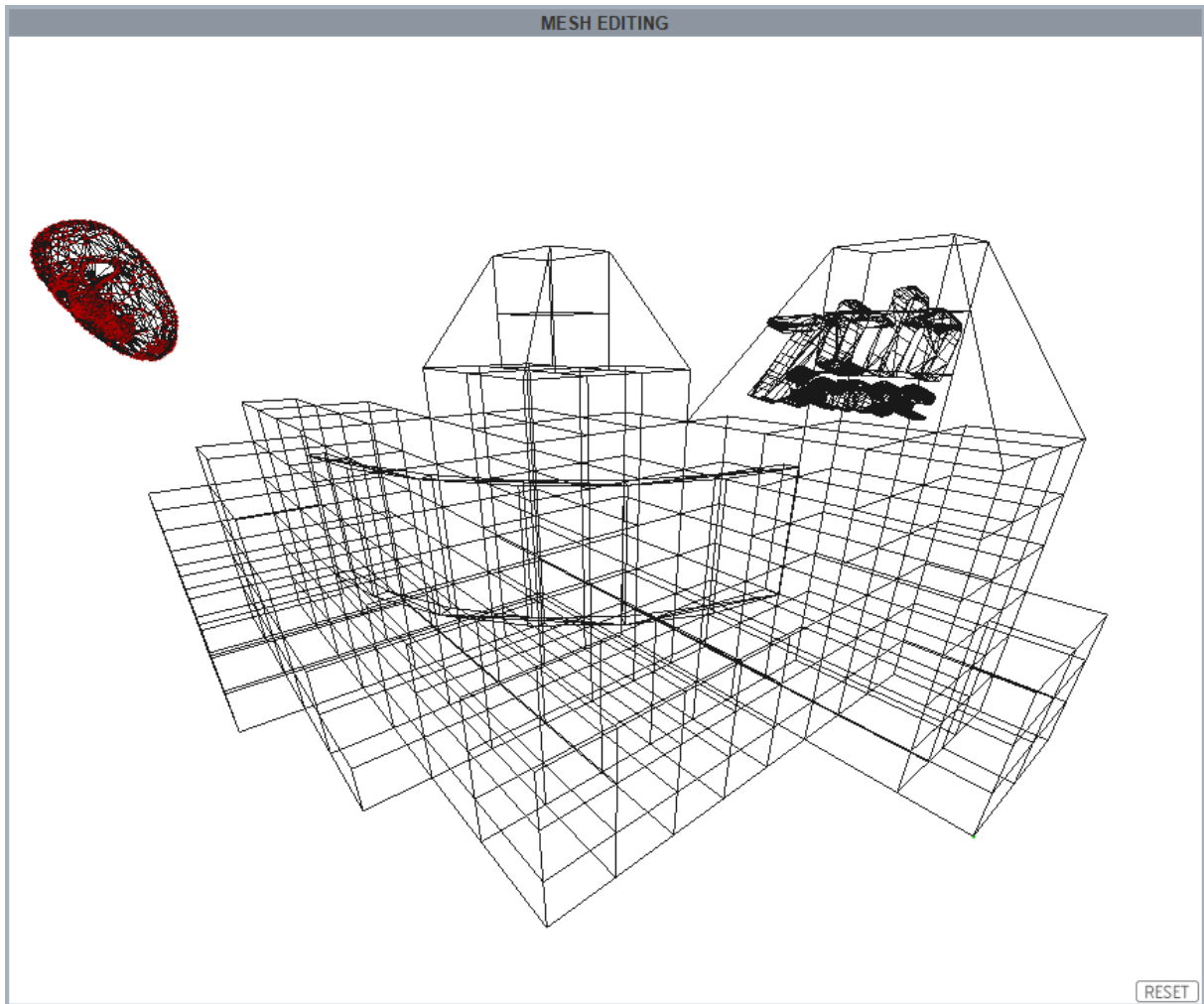

**Rotation** is available, again in the selected movement plane axis, either about the central rotation point, or a selected point (click the green button to switch this).

The vertex group can also be **scaled** about the same point, increasing or decreasing all vertex separations proportionately. Here we can see that by selecting the X-Y movement plane, rotation will be about the Z-axis:

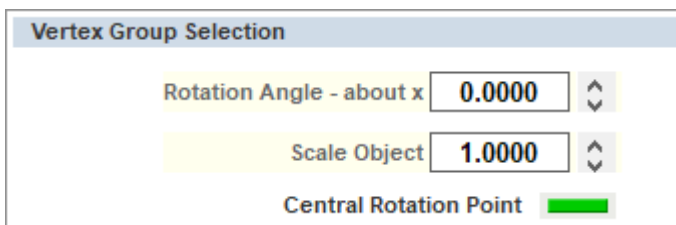

These adjustments can be seen in the editing screen above.

What moves?

If the mesh and media are texture-mapped, the media will follow the moved element, so the media can be adjusted to a real-world object that does not quite match.

If the media is not texture-mapped (i.e. projection mode), then it will continue to be projected in situ. This is not the same as warping the mesh.

**Hiding points:** There are two ways to affect the projected display of selected parts of the media: Show/Hide and Black/Paint. Hiding a group removes all edges joined to the selected vertices, and enclosed faces. Single vertex selection is not useful for hiding, but a single vertex in a small group may be. In the example below, per channel selection has been made on the oblique sides in channel 1 (left), to be filled exclusively by channel 2 (right). In the first Playback Window illustration below, **Hide** removes faces from display, in the second, **Black** fades it out, similar to blending.

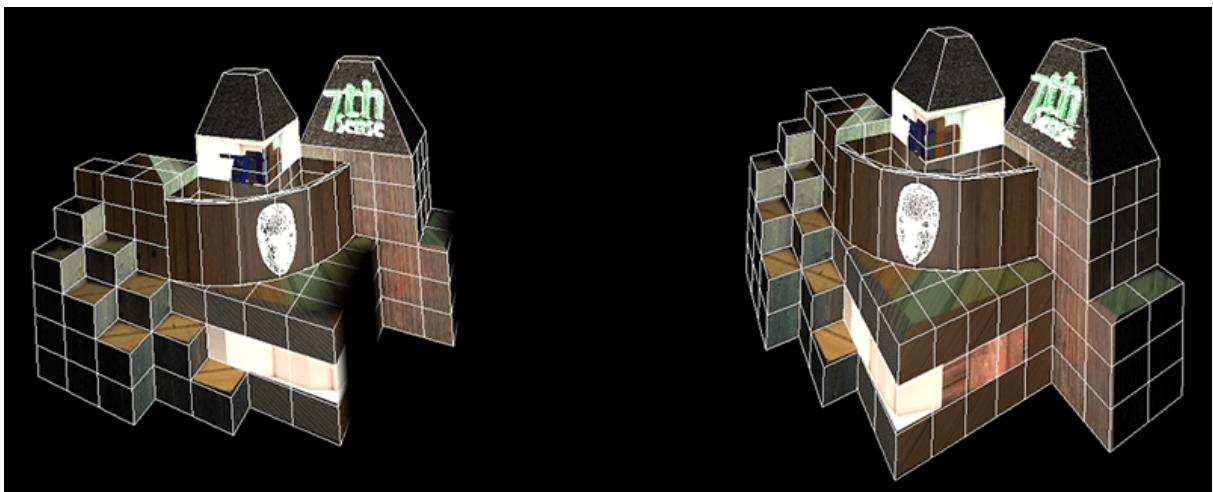
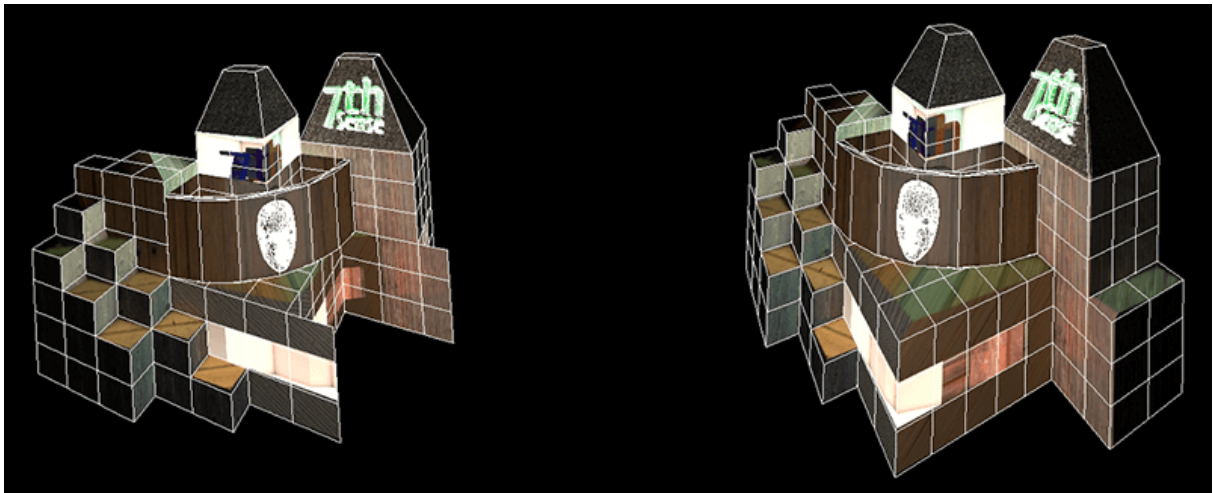

Note how vertex selection has not included the vertical edges required by channel 1.

Compare this with [adding a blend](#)<sup>248</sup>, and the need to preserve display on edges; a blend may fade out more than you want. Blends are more suitable for textured mode.



When mesh editing, Playback will show in blue-green colour, indicating that it is in low-performance mode. Restore this by going back to channel mode.

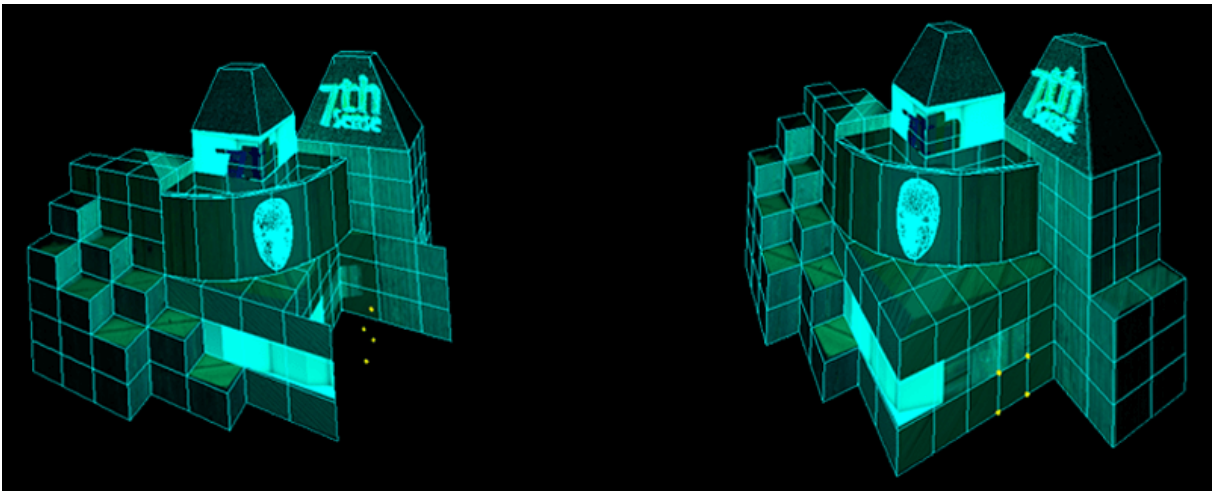

**Clipping Planes**

These contain your view for selection, between Near and Far planes. Use the **Fit** button to set the range to the size of your mesh, otherwise the mesh can be too small a part of the maximum available range, and disappear from view. In this example, clipping planes have been used to limit selection to points on the facing wall in the above illustration:

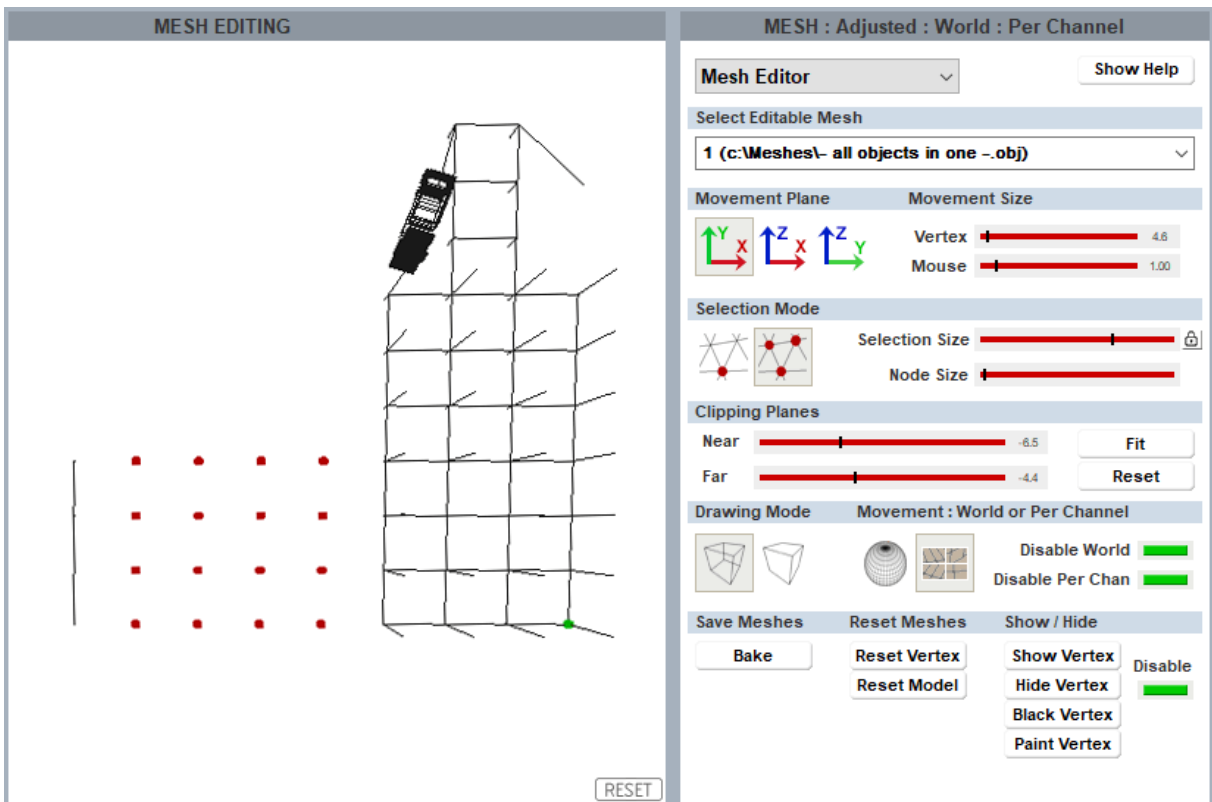

**Save Meshes**

You can save changes to the mesh simply by using *File > Save As* (and then Save to save

further changes). This saves the original .obj file, together with .vto files containing adjustment instructions. Every time the mesh is used for a show, these instructions will be applied. 'World' and 'Per Channel' change files are created separately.

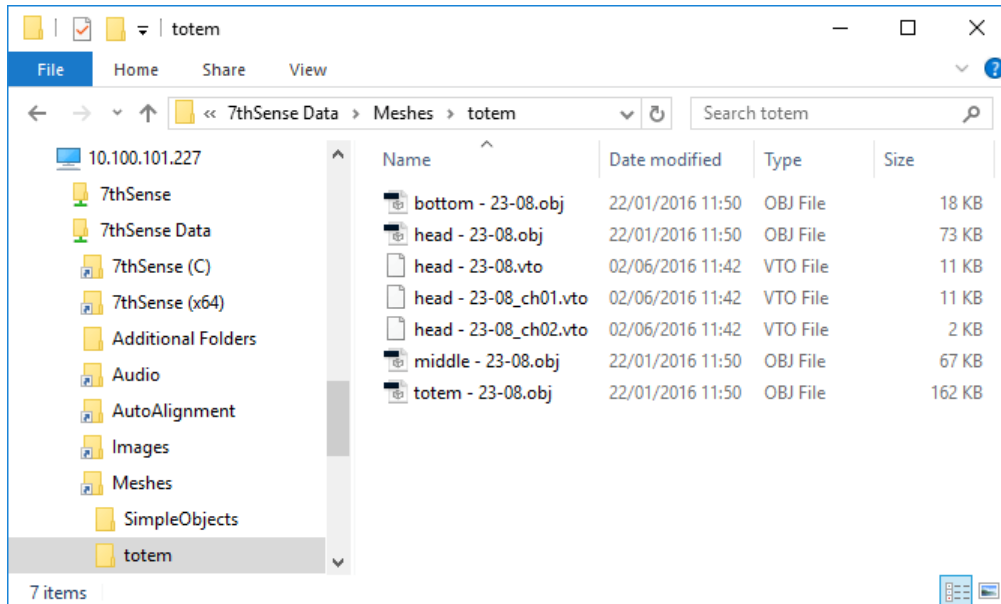

**To remove the changes**, returning to the original mesh alone, simply reset in the GUI or delete the .vto files here. If you have 'Sync Mesh Files from Server' ticked in the Mesh selection screen, the files will also be copied over automatically to the GUI.

The mesh editor, however, also allows you to 'bake' the changes into either a new single revised 'world' .obj file, or a new .obj per channel. Changes cannot be reset in a 'baked' file.

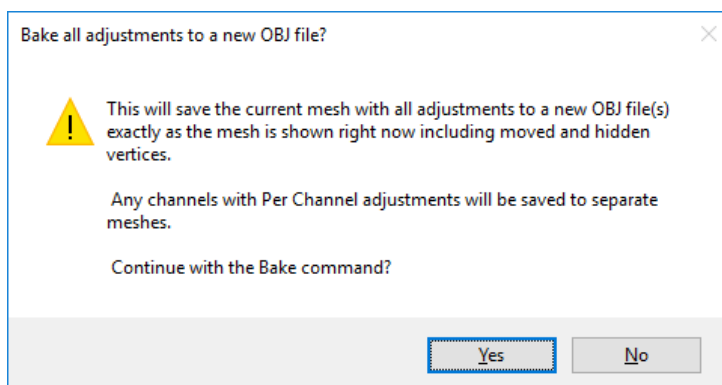

### Reset Meshes

Note that resetting the whole model sets all vertices back to their original positions in their .obj file. If you have loaded an .obj file that has associated .vto files, resetting the model removes the .vto amendments from view, and if then saved, the .vto files are removed from the C:\Meshes directory. If in doubt, and you want to compare before and after adjustments, use the Disable button instead.

## Movement Nodes

Movement nodes add the capability to synchronise movement between meshes, media and eyepoints using their names in **Sequences** (see Delta User Guide). By manipulating a parent node, linked nodes will follow without separate programming. Examples include rotating images on car wheels, growing and moving two eyes together, or bringing several meshes into view simultaneously.



The three controls are: create or delete nodes (third button), assign nodes to eyepoints (first button), and assign nodes to meshes (middle button).

## Creating a Movement Node

Node translations for each parameter can be set by the setnodeparams external control command, or use the Node Parameter editor in *Display Config > Mesh Mode > Movement Nodes* and double click on a node. There are six sequences of Translate (change XYZ coordinates), Rotate (HPR angles) and Scale (XYZ relative dimensions), though not all three aspects may be needed.

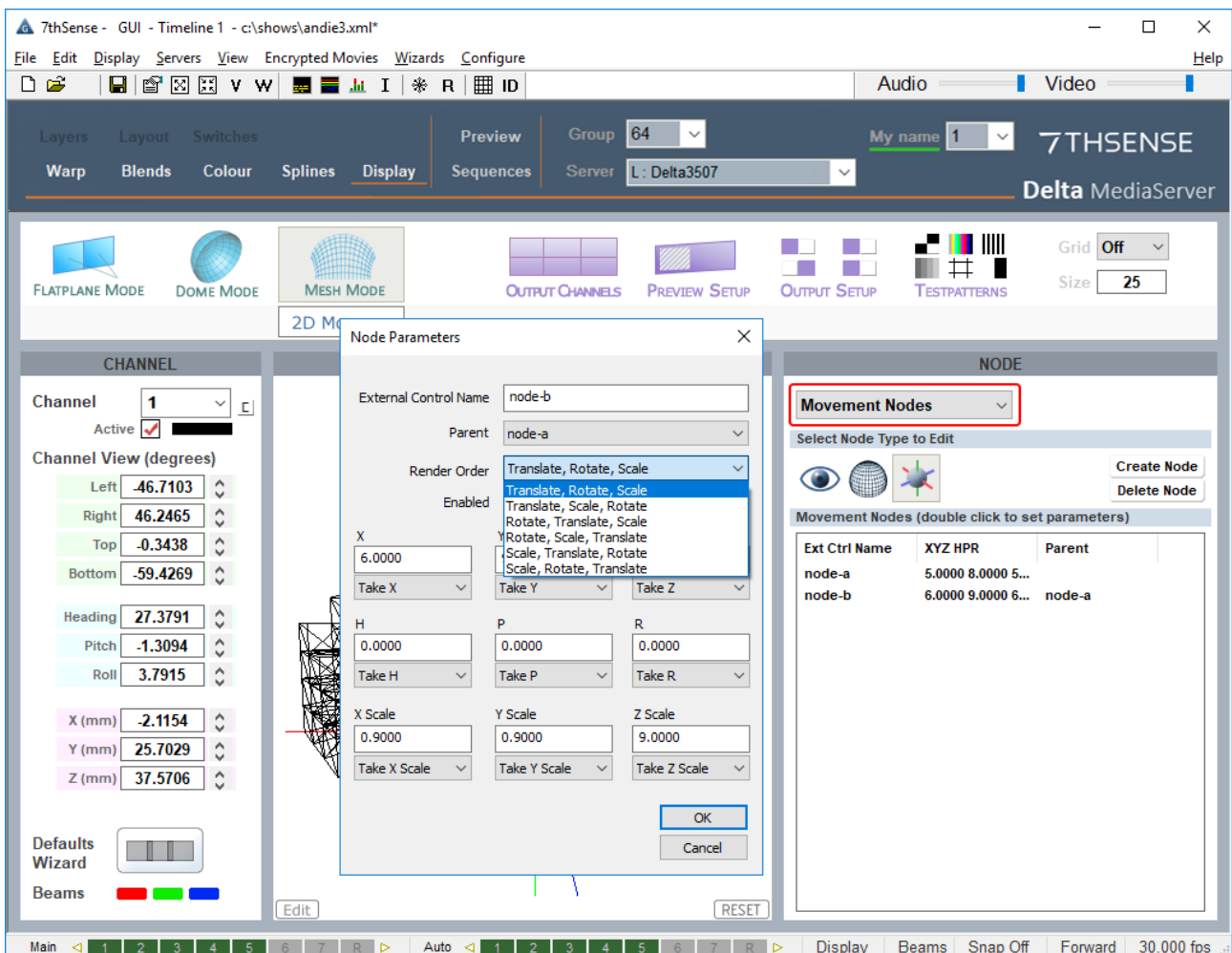

- To synchronise multiple movement nodes, one must be a parent and the others assigned to it.
- Movement nodes are assigned to eyepoints and/or meshes.

- Movement nodes can also be addressed by External Controls (see the Delta User Guide for how to use these). For available commands in DeltaGUI, Click *Help > External Controls* and find Movement Node Commands:

Command	Arguments	Description	Examples
CREATEMOVEMENTNODE	extctriname=name [x=xval] [y=yval] [z=zval] [h=hval] [p=pval] [r=rval] [xscale=xscaleval] [yscale=yscaleval] [zscale=zscaleval] [order=orderstring] [enabled=y/n] [parent=extctrinameofparent] [takex=**] [takey=**] [takez=**] [takeh=**] [takep=**] [take=**] [takeyscale=**] [takezscale=**]	Create a movement node which can be addressed from external control and meshes or eyepoints attached to it (see ** below)	
SETPARENTNODE	target=[mesh/eyepoint/node] [index=1-16 / ALL] [node=nodeextctriname] [parent=extctrinameofparent] [detach=true/false]	Attach a mesh, eyepoint or other node to this node	setparentnode target=mesh index=1 parent=myparentnode setparentnode target=eyepoint index=3 parent=myotherparentnode setparentnode target=node node=nodeextctriname parent=myparentnode setparentnode target=mesh index=ALL detach=true
DELETENODE	None	Delete an existing movement node	
SETNODEPARAMS	extctriname=name [x=xval] [y=yval] [z=zval] [h=hval] [p=pval] [r=rval] [xscale=xscaleval] [yscale=yscaleval] [zscale=zscaleval] [order=orderstring] [enabled=y/n] [parent=extctrinameofparent] [detach=true/false] [takex=**] [takey=**] [takez=**] [takeh=**] [takep=**] [take=**] [takeyscale=**] [takezscale=**] [takeyscale=**] [takezscale=**]	Set an existing node's parameters (see ** below)	

- Each parameter of the node (XYZ, HPR, XYZScale) can be set to act as any of the others – or be ignored, so for example the X value used for a node can be taken from Z or even -Z, or the XScale value can be set to be ignored:

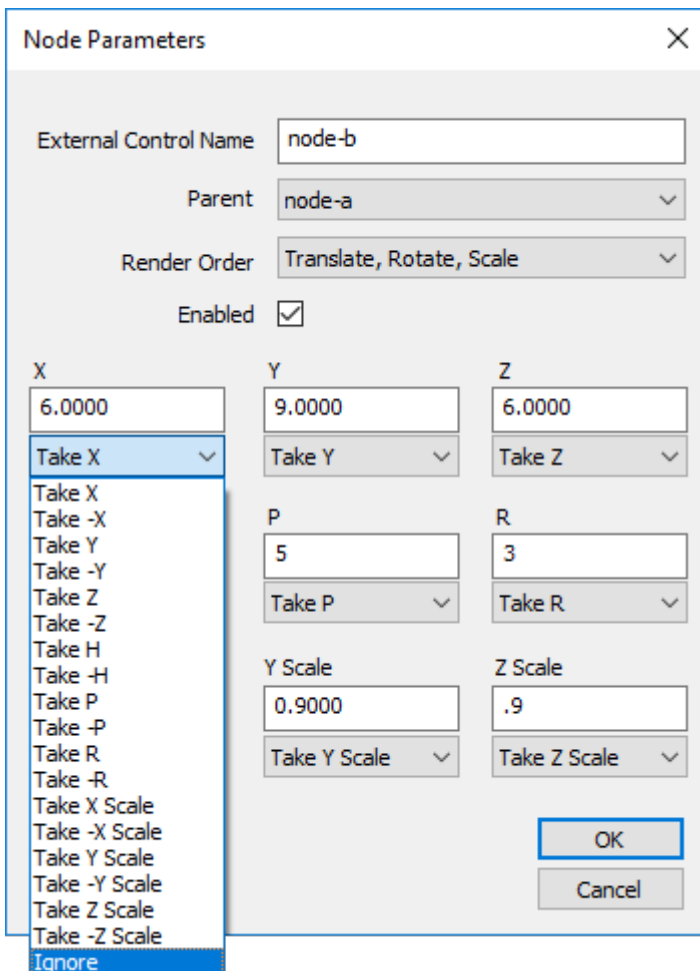

- The values shown in the dialog are always the untranslated values, the translation happens internally in the render stage.

- This translation can be used to take care of axis differences between systems or to ignore certain values from a datastream that are not interesting.
- Node values can be set by external control (using setnodeparams), ArtNet (via setnodeparams) or NatNet tracking input.

## Mesh Optical Tracking

For users of OptiTrack Motive systems for optical tracking, Delta can use Motive's NatNet streaming data over IP, linked to DeltaGUI's [Movement Nodes](#)<sup>(267)</sup>.

### In OptiTrack Motive

Enable 'Broadcast Frame Data' in the OptiTrak Streaming Engine and connect the Motive source Data Port with the Delta server as client over NatNet. For details on the streaming engine, see [https://v22.wiki.optitrack.com/index.php?title=Data\\_Streaming](https://v22.wiki.optitrack.com/index.php?title=Data_Streaming).

Output node **1** will be identified in Delta as movement node name: **natnet\_1**

Output node **2** will be identified in Delta as movement node name: **natnet\_2** and so on.

### In DeltaGUI

First, NatNet must be enabled in DeltaGUI > *Preferences* > *Misc Settings*:

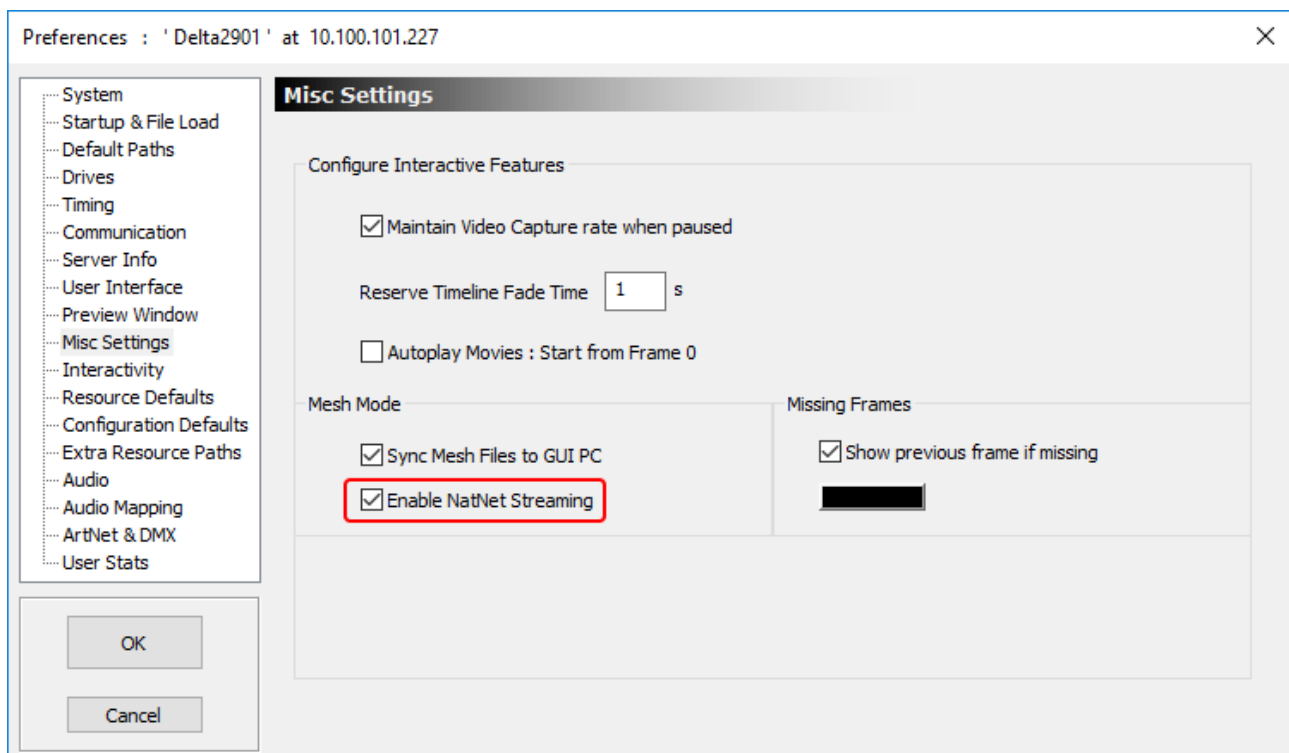

Connections can now be made to meshes and/or eyepoints, by creating and naming a **movement node** for each:

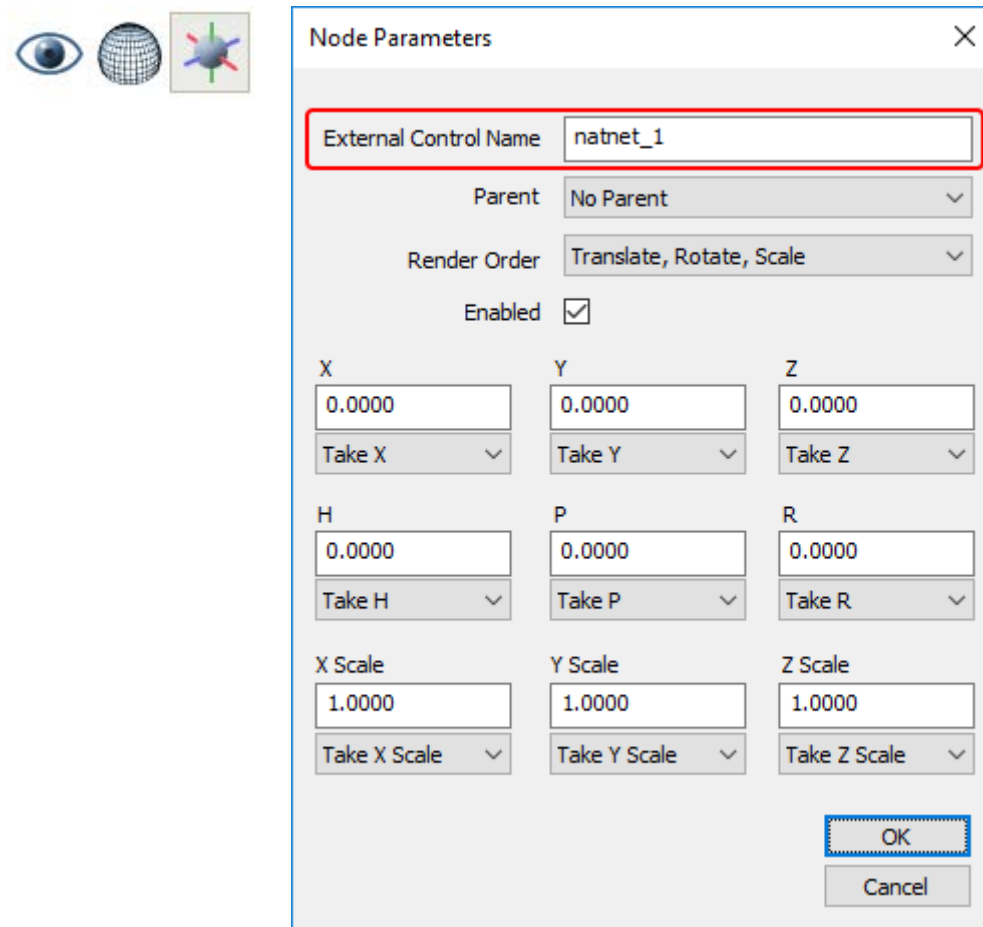

The node(s) can then be synchronised with a mesh or an eyepoint, by making the NatNet node a parent.

Example: take the mesh you want to connect the NatNet node to as parent, and double-click to edit it:

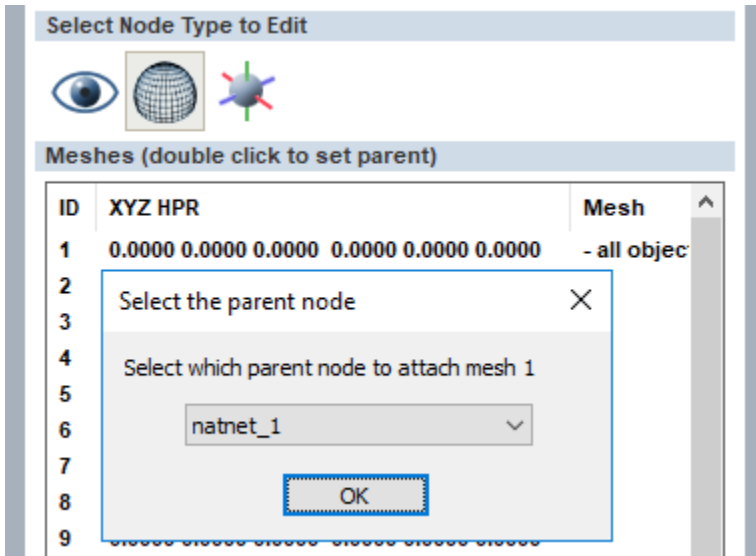

Assign the NatNet node name as parent.

The XYZ-HPR and scale values of the NatNet node can now be taken by the mesh (or eyepoint).

### Transformation Example

Node values be used directly, or in more complex scenarios, can be transformed, for example to reverse orientation, invert, or convert roll to pitch. For example, here we want to take the orientation of an active puck and transform its **roll** movement to change the **heading** of a car:

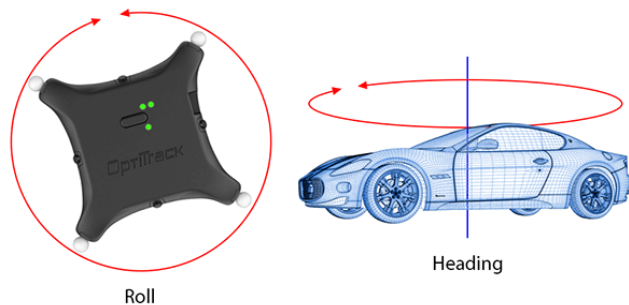
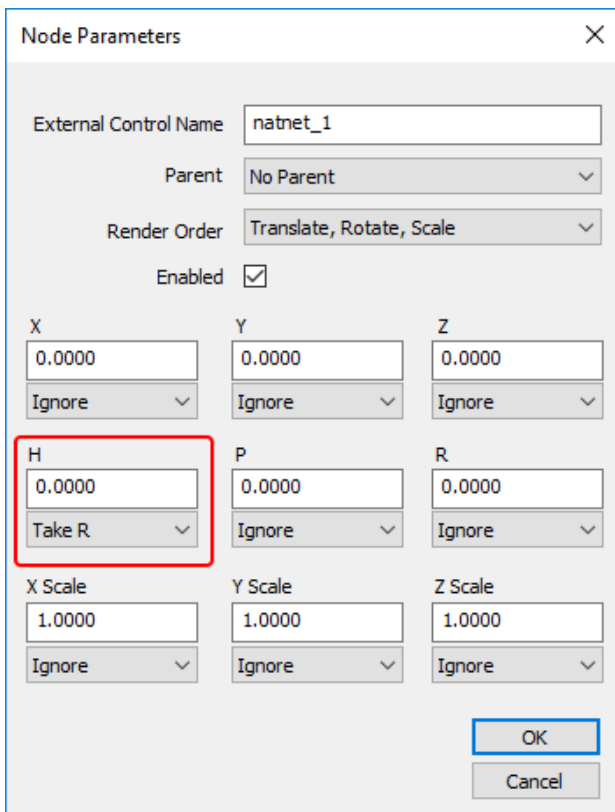

## Switches

This view provides control over beams, geometry and blending for all channels in all servers and an overall summary of all the server's display configurations.

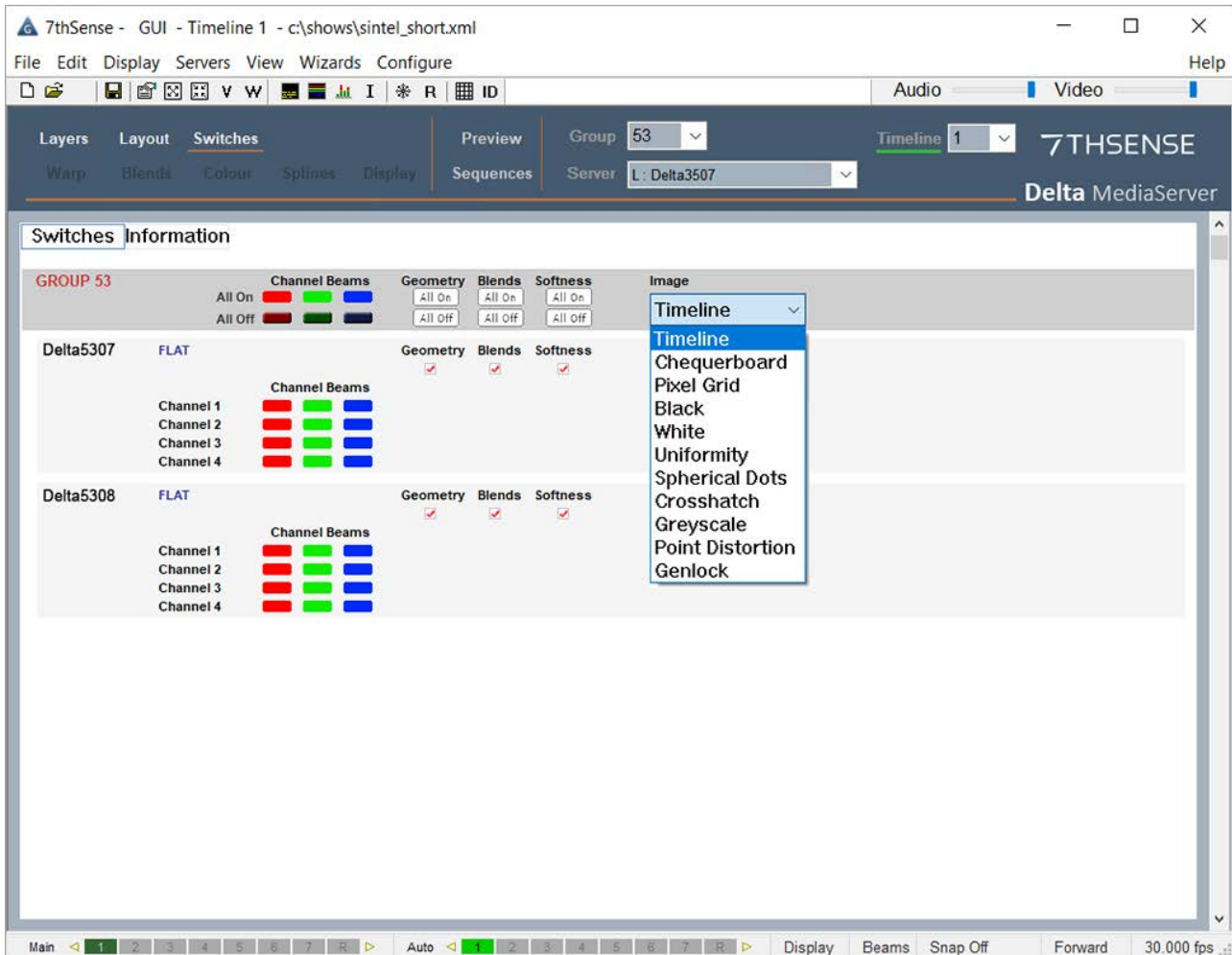

By switching individual beams off, attention may better be given to a particular channel.

Switching geometry off affects not just display geometry (warp) but geometry applied to specific resources on timelines.

Select from 'Image' to apply a test pattern to all channels in the server group.



In the Information page, you can see each channel's location and size for all servers in the group:

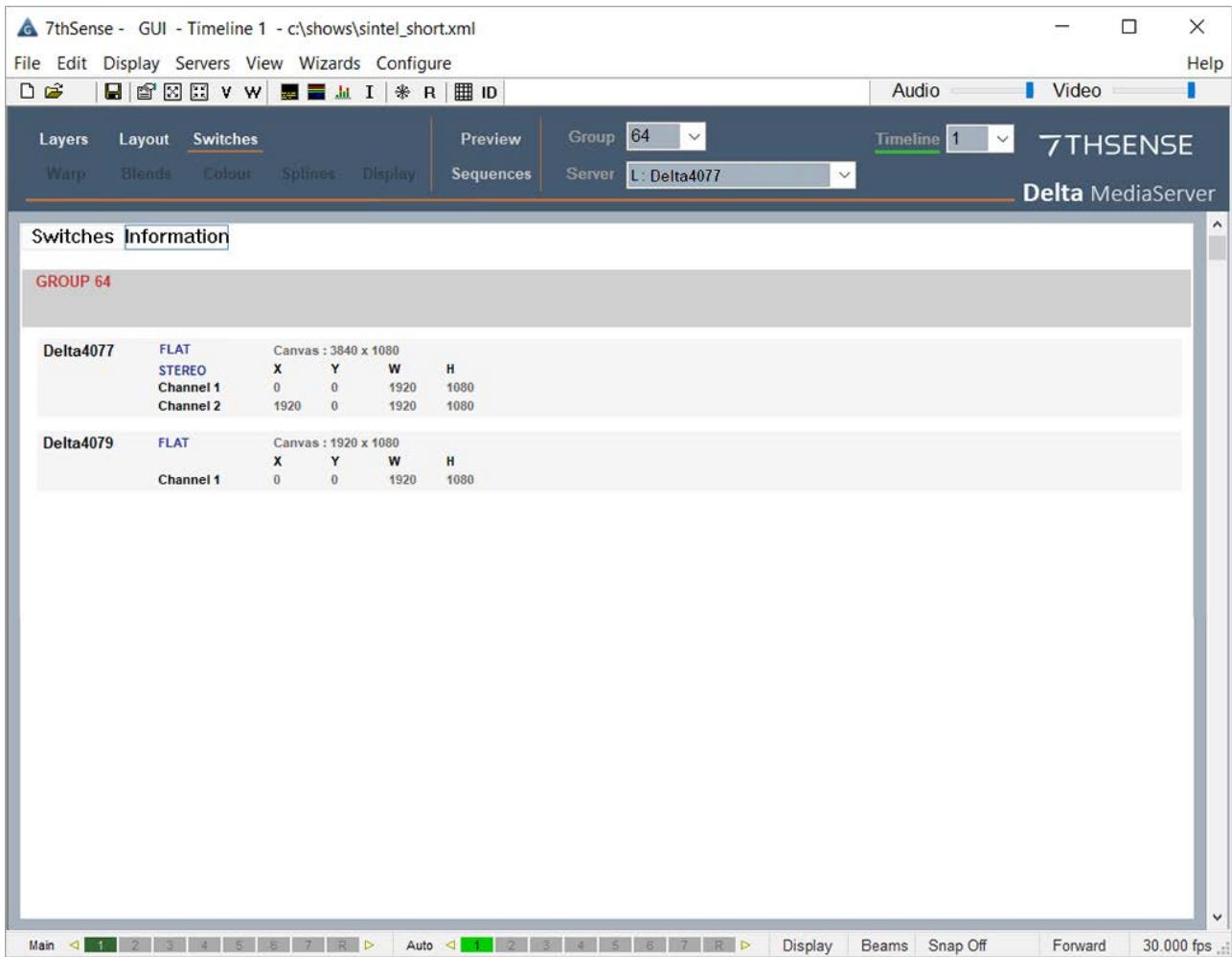

## Populating the Timeline

The first thing to appreciate before you begin, is that a 'Resource on a timeline' is not moving any files anywhere. A Resource on a server's timeline is merely a reference to a file or sequence of files on the server's disks, with a set of instructions or parameters to say how the media will be played and displayed (how much, how fast, how long, when to start and stop, where, what colour etc.).

Start DeltaServer and DeltaGUI. At this point, there are no resources on the timeline (assuming there was no default file set to load), and any resources found in the relevant folders are presented in the Resources Area on the left.

Select the media type (in the example below, Images), and double click the image you want to add to the timeline. The Add Resource dialog is displayed, so choose a name for this resource, which layer and where along the timeline you want it to be placed.

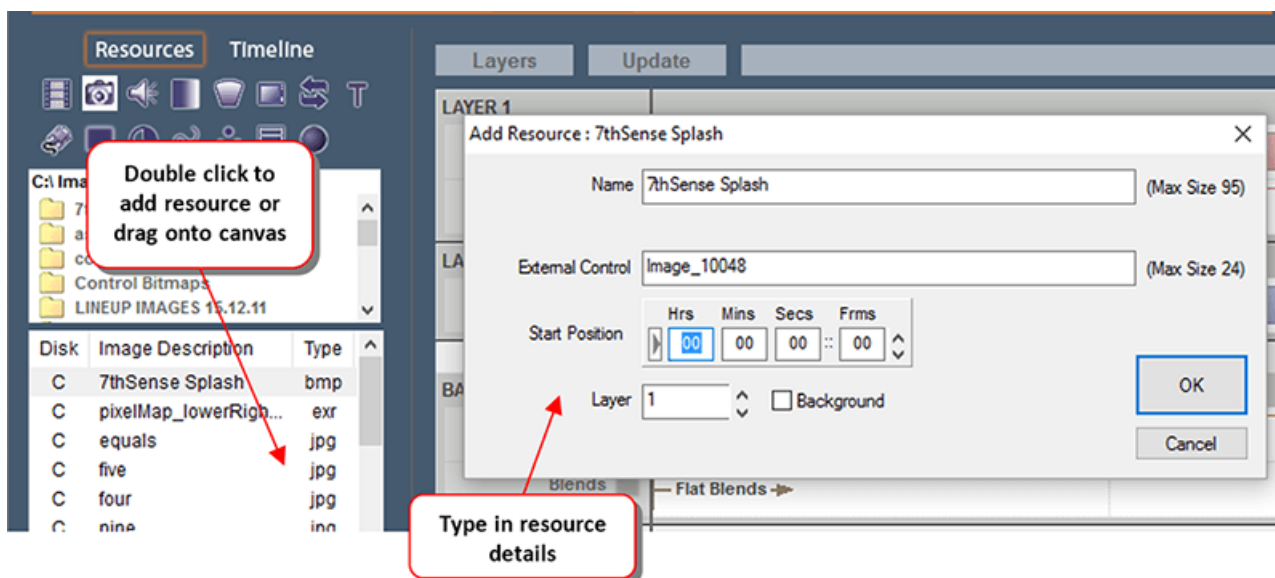

After pressing OK on the Add Resource dialog, Layer 1 is shown, and the Resource Area shows you the newly created resource on the Timeline.

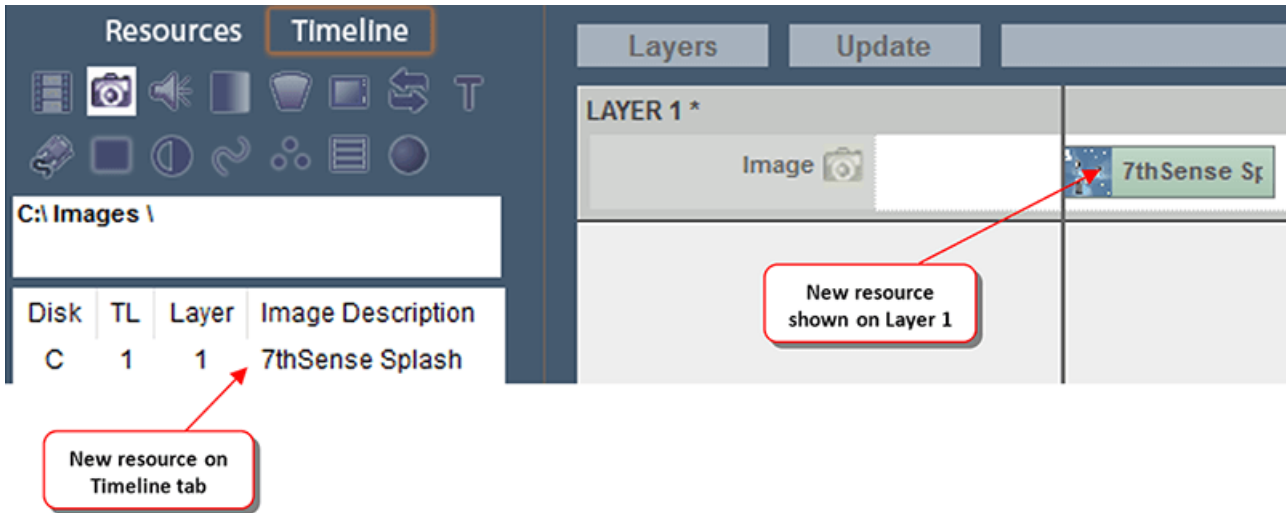

## Warnings

There are various warnings if there is a problem with a resource. A movie file may be encrypted and not match the playback licence (see [Delta Content Protection System](#)):

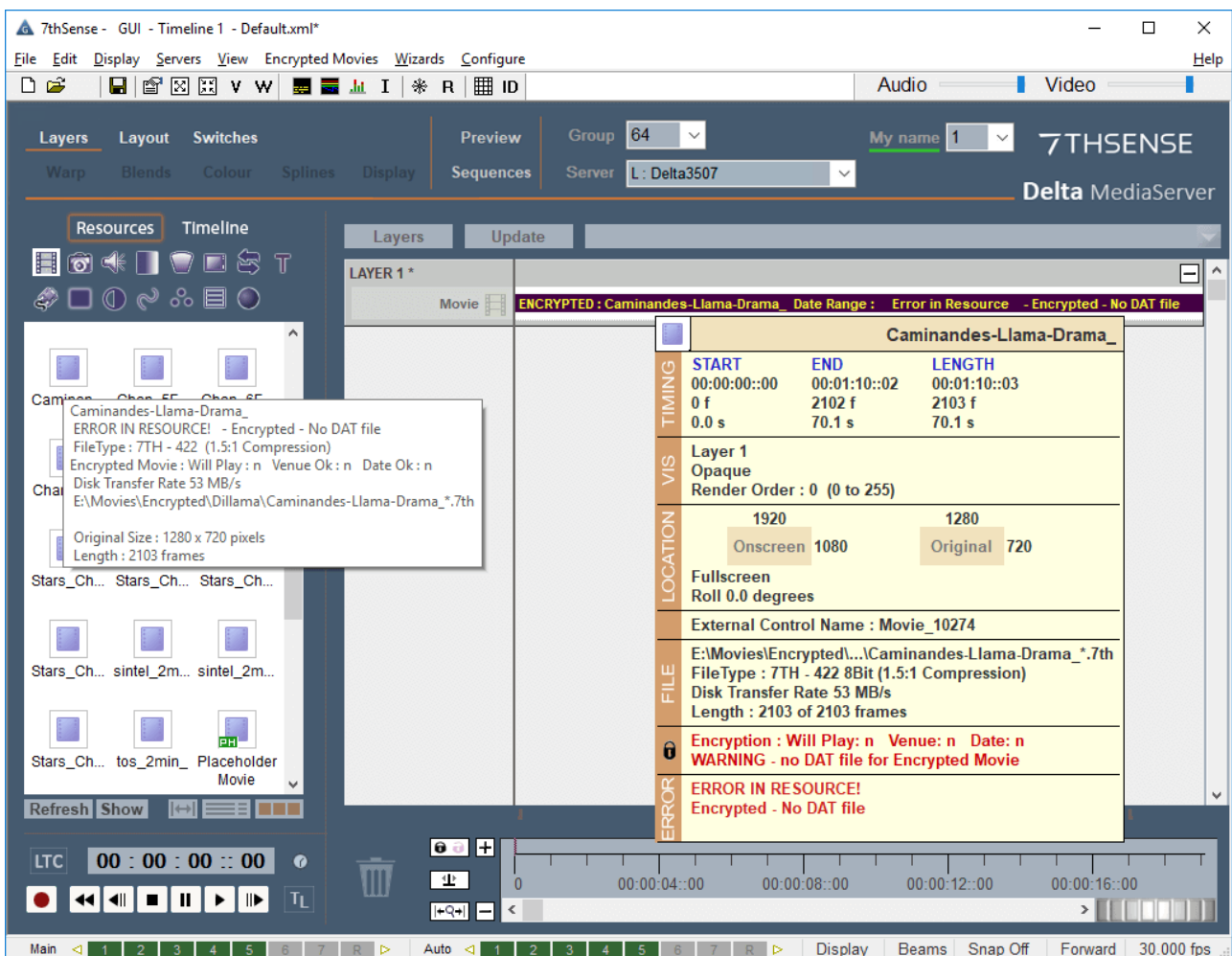

Errors can be seen in three places, in the timeline, by examining the timeline resource, or by hovering over the resource in the pool area.

Similarly, if there are missing frames in a movie (i.e. not in codec formats), this will be highlighted in the timeline resource properties, and in the resource pool the resource will have a red frame (or in list mode, the name will be in red type):

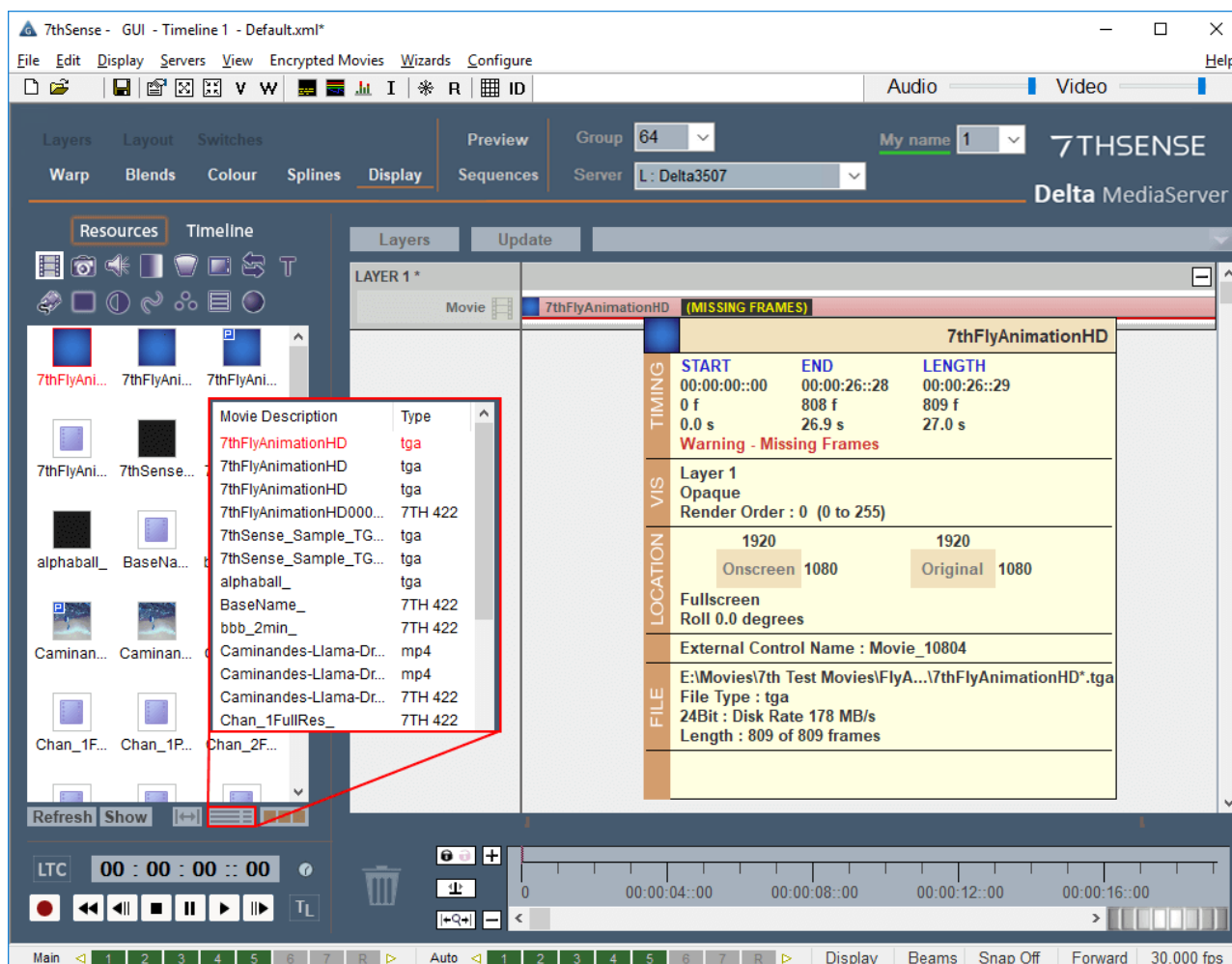

## Interact with Resources on the Timeline

Media on the timeline can be **moved** along the timeline simply by left-clicking on it and dragging it while the left mouse button is down. When moving your mouse over the media resource on the timeline, the pointer changes to  to indicate that the resource can be moved left or right.

While moving, the resource is shown in yellow, and the start / stop positions on the timeline are shown as you move.

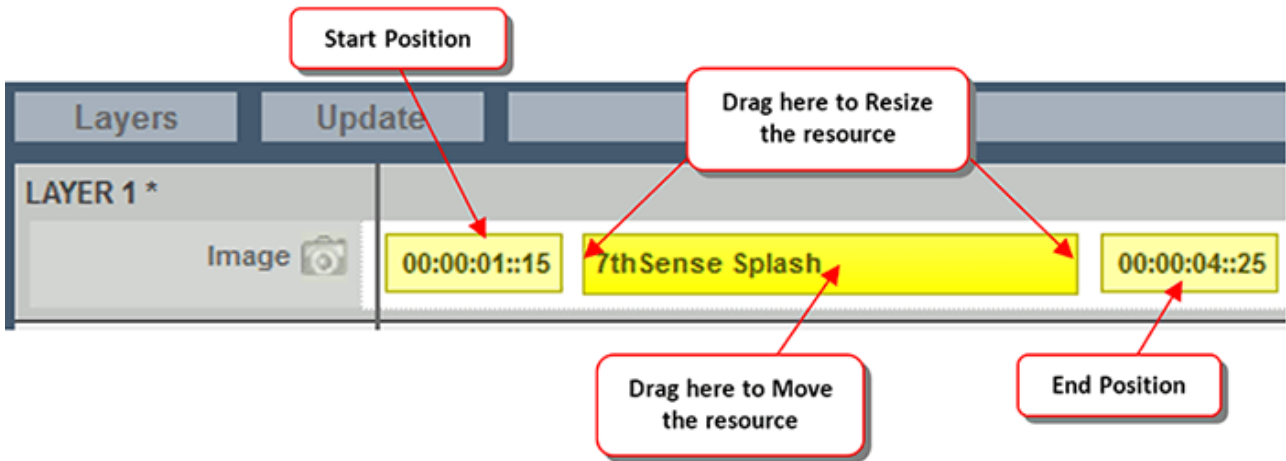

To **change the length** of the resource on the timeline, simply move the cursor over either end of the resource on the timeline; the cursor changes to  $\leftrightarrow$  to indicate that you can pull that end of the resource. If the resource is very short on the timeline, you may not get the sizing cursor – simply zoom in until the resource is large enough, or edit the resource properties (right click on the resource > Properties ) and type in the start and stop frames / times.

To change which part of the timeline you are viewing, use the controls below:

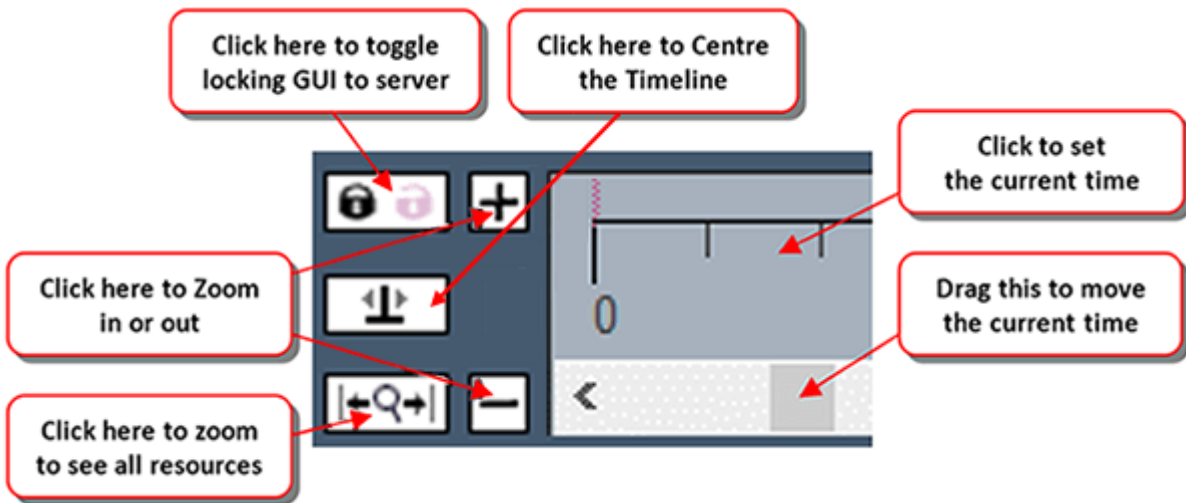

If you can't see enough of the resource, use the timeline controls to zoom in or out, and centre the resource in the visible part of the timeline.

## Drag and Drop onto the Timeline

You can drag media from the resources area directly onto a layer, or drag it onto the blank canvas to create a new layer. If a media resource is not immediately available, you can use a Placeholder (Controls media type) to occupy the space and position, and replace it later when the media resource is available. Alternatively, you can use a Movie or Image Placeholder resource, which is a dummy resource rendered as a rectangle onscreen. Using the Replace Resource method (Ctrl+drag a resource over the placeholder), you can then replace this placeholder at any time, maintaining previously set parameters.

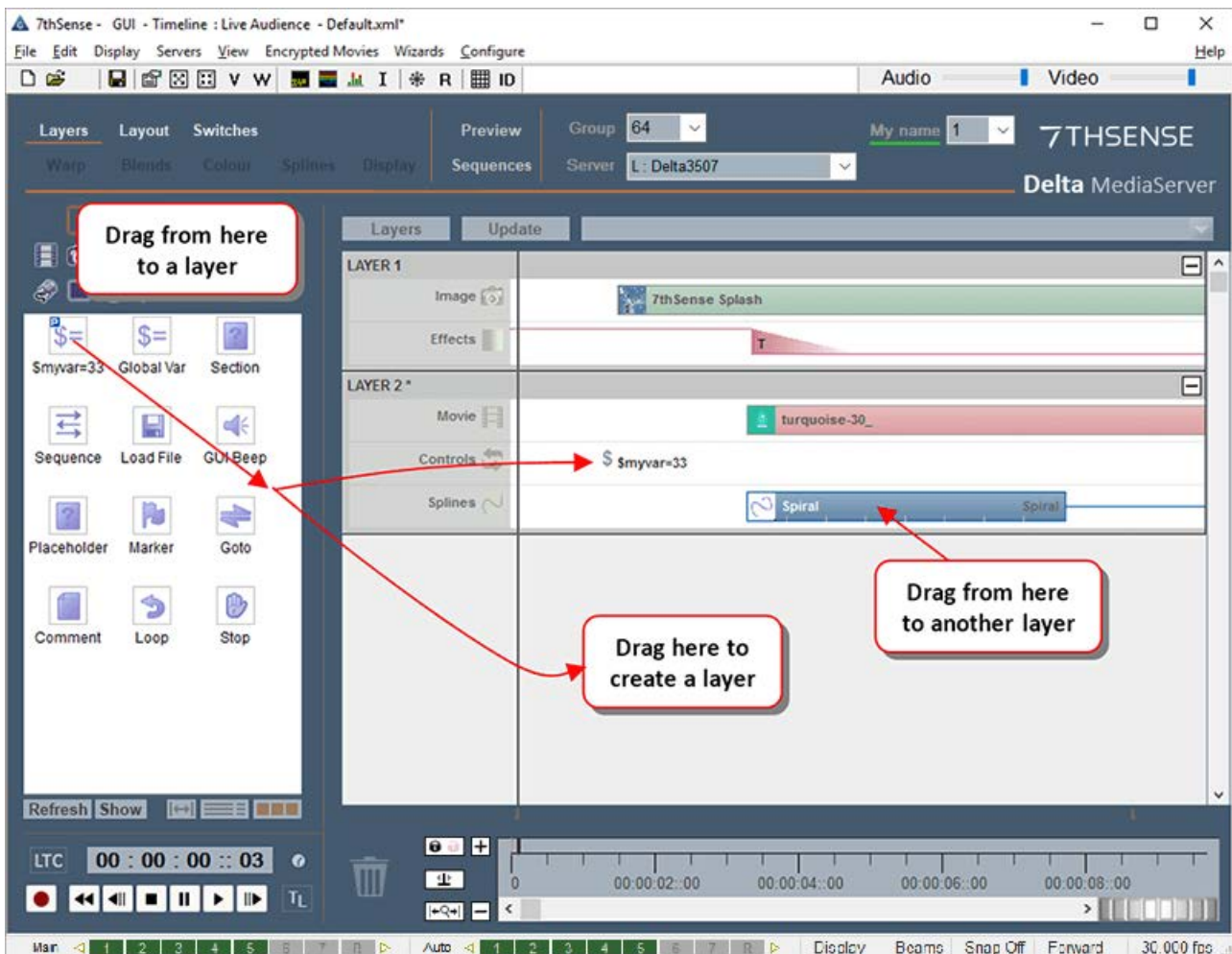

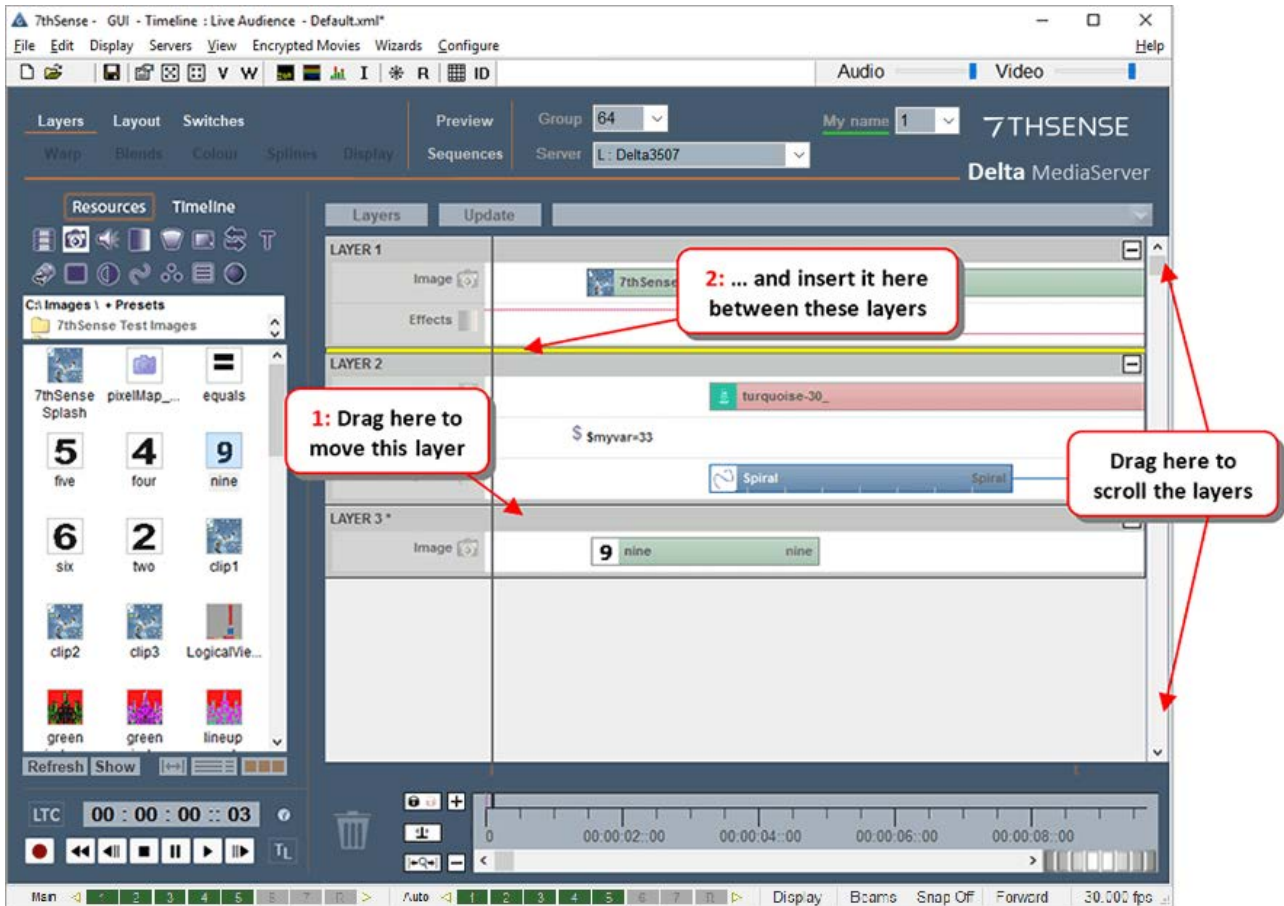

## Group Selection of Media (Rubber Banding)

In addition to dragging resources from the resource area to a layer, you can select or lasso multiple resources with a rubber band (drag a marquee). See also: [Copy Timeline](#) <sup>(57)</sup>.

If you wish to move several resources along the timeline, left click somewhere away from a resource in the white area the rubber band to cover the resources (they turn green to indicate selected). Then drag this group left or right along the timeline.

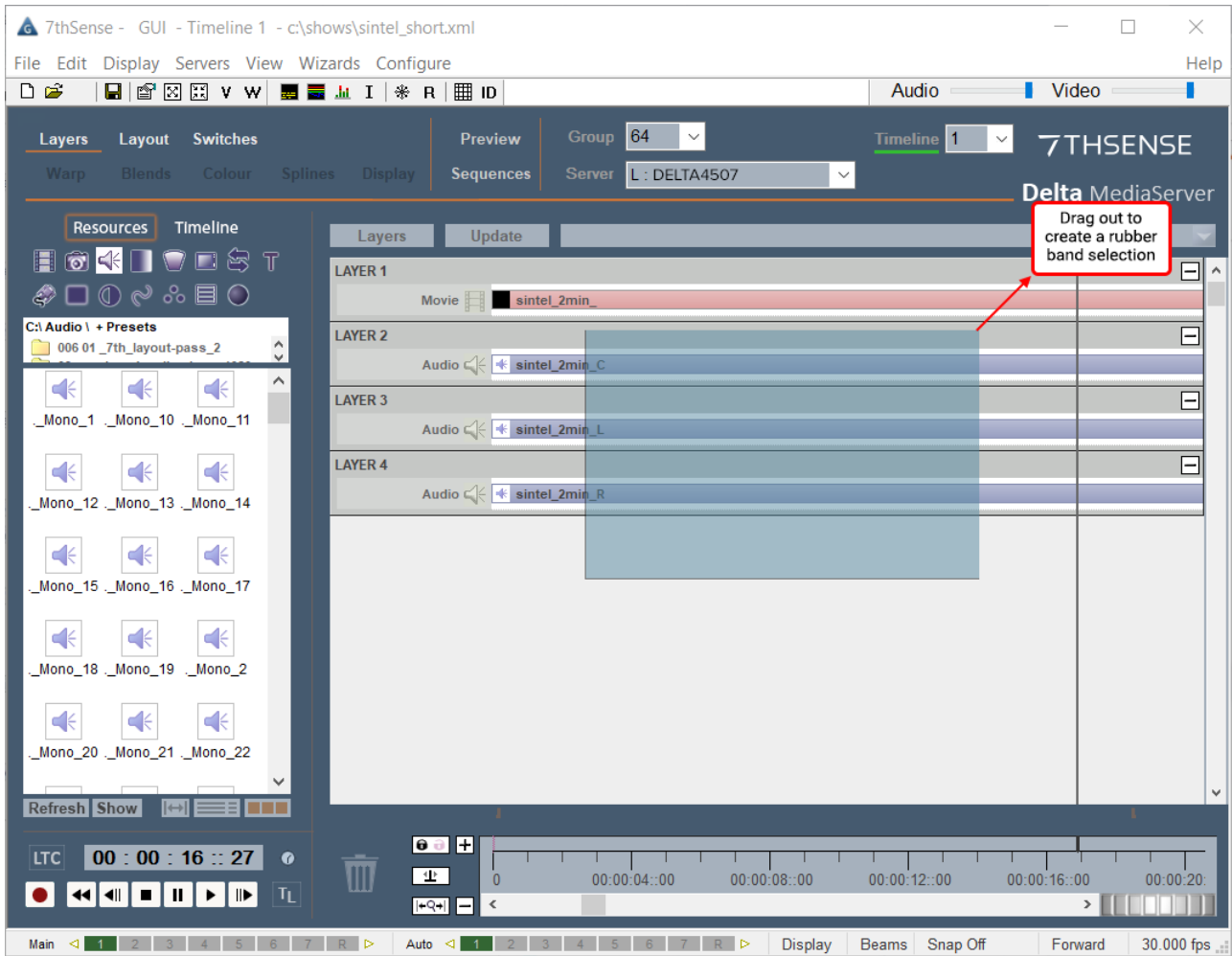

**Notes**

- Hold Shift down while rubber-banding to add to or remove from the current selection group.
- You can rubber-band over the timeline controls area as well
- You can rubber-band over closed layers (selects all within the closed layer)

Once two or more resources are selected, you can use cut, copy, paste or delete on them:

<b>Cut</b>	CTRL+X	Cuts the selected resources from timeline, and stores in the Clipboard
<b>Copy</b>	CTRL+C	Copies the selected resources from timeline, and stores in the Clipboard
<b>Paste</b>	CTRL+V	Pastes the clipboard resources (if any) to the current cursor location on the timeline. Note that resources are only ever pasted back onto the layer they were copied from.
<b>Paste At</b>	CTRL+B	Pastes the clipboard resources (if any) to a frame or time that you specify.



<b>Delete</b>	Del	Delete the selected resources (or drag them to the wastebasket).
<b>Select All</b>	CTRL+A	Select All resources in this timeline
<b>Deselect All</b>	CTRL+D	Deselect any selected resources

These items are also available on the menu under Edit.

In addition to dragging a resource from one layer to another, if you press **CTRL while dragging**, you will create a copy of that resource to the same or other layer.

## Media Placeholders

In the Images and Movie resource pools are placeholders marked with a green 'PH':

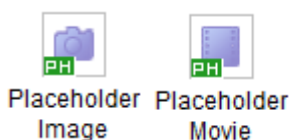

Designed to be filled by real media when available, these can be dragged onto a timeline layer and be configured as if a regular image or movie file. An image will show on playback as a green area (size and position as defined), and a movie as pink. (These default colours can be changed.)

**To replace a placeholder** with final media, drag the media file from the pool, on top of the placeholder whilst holding the **Ctrl** key:

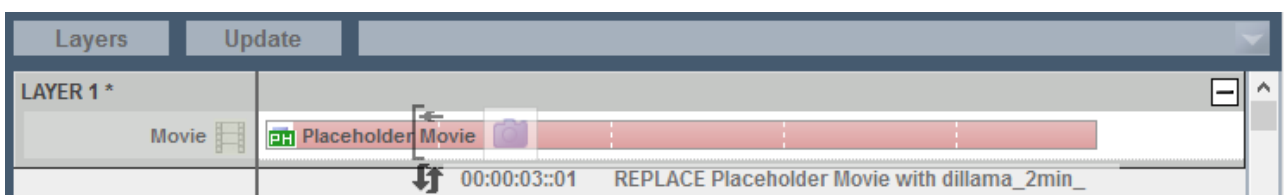

When you see the double arrows and REPLACE message, release the media into the placeholder.

**To clone a placeholder's properties** for a new piece of media, drag the media from the pool, on top of the placeholder whilst holding **Ctrl+Shift**:

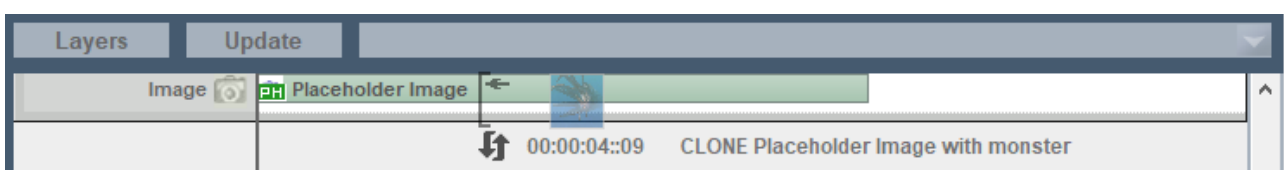

When you see the double arrows and CLONE message, release the media into the placeholder. The placeholder will remain, and the new image will be placed with the properties of the placeholder.

## Replacing / Cloning Resources

---

Dragging a resource from the **resource pool** over an existing resource on the timeline usually just creates the new resource on the same layer, but pressing **CTRL** while dragging over an existing resource will instead **replace** the timeline resource with the new one from the pool, keeping its existing parameters (screen location, colour etc.).

This can be used as a template tool, where you create a timeline before the actual media is available, by setting up a movie or image etc. on the timeline, then when the real media arrives, Ctrl drag it over the existing media, keeping the previously setup parameters.

By holding **CTRL+SHIFT** down and dragging a resource from the pool over an existing resource, the original will be left in place, but a new resource with the same parameters will be created (**cloned**).

### Notes

- Replace / Clone is only available on Audio, Capture, Images and Movies.
- You can only replace like with like, for example, an image with another image.

## Cutting, Splitting, Aligning, Looping Media

---

Right click on any media (or layer) for additional options besides the double-click properties dialog:

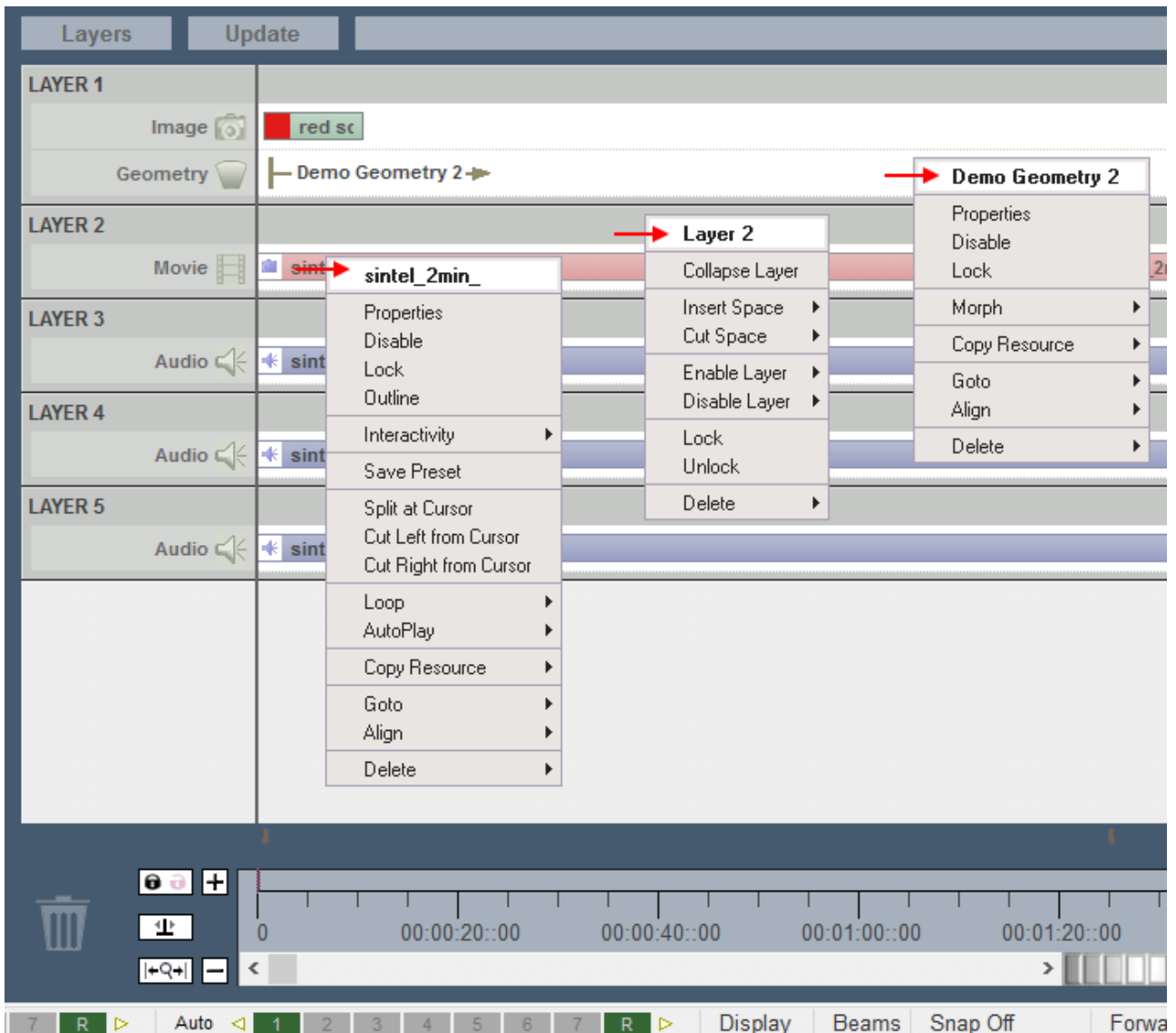

### Disable/Enable

Temporarily stop a resource or Layer from running on the timeline; shows greyed out until enabled. This server's Timeline, or all Layers of this index in a server Group, or all GUI-connectable servers, may be selected.

### Lock/Unlock

Prevent item being moved from its layer, duration or timeline position, but not its properties.

### Outline/Clear

Draws a moving outline around a resource, for visibility.

### Interactivity (movies) > selectable: movable

Enables touch-screen operability on selected items only.

### Save Preset

Save the resource with its properties to a new name to be reused. This saves as a .CLP file in

the Presets folder, with all resource parameters saved in the CLP file, and referring to actual media on disk. Using presets, you can save commonly-used variants of existing media.



These show in the resource pool with a P in the top left corner.

### Insert/Cut Space (layers)

Space can be inserted or cut from one or all layers. The effect is to move the start position of resources to the right (insert) or left (cut), along the timeline. Space will be inserted or cut at the playhead cursor. If a resource lies across the cursor, no space will be inserted or cut from that resource. If more space is cut than is available between resources, they will overlap. If all layers are selected, space will be inserted or cut from all layers.

### Split at Cursor

Divides the media resource at the current playhead (cursor) position. Either part can be moved separately on the layer or between layers. This does not affect the original resource, it merely provides time-separable windows on the source media. Split parts cannot be rejoined. Either replace the split parts by the original resource, or ensure they run consecutively to the frame.

### Cut (left/right) from Cursor

Cuts the media resource at the current playhead (cursor) position and discards the part to left or right. This does not affect the original resource, it merely provides a window on a selected part of the source media. This can be saved as a Preset, but it remains volatile (e.g. looping will restore the original media length first). To create a true clip of the media resource, set start and stop frames in Properties [File(s)] and save that as a preset.

### Loop (movies)

Switches on and off looping of the source media file so that dragging the resource out will repeat it without break to a point in time. The Movie Resource Editor dialog also offers extension with 'Hold on Last Frame' instead of repeating from the beginning. A count of loops can be entered as a set number of times in the Properties page (see also: [Seamless Looping](#)<sup>(290)</sup>).

### Loop (audio)

As for movies, but AudioSeamlessJoins must also be activated the registry to ensure no clock cycles are missed (see: [Seamless Looping](#)<sup>(290)</sup>).

### Autoplay (movies)

An autoplay media resource that is in scope will continue to play when the timeline is stopped, and loop-repeat continuously until the playhead is moved off it.

### Pitch Correction (audio)

If an audio track needs to be time-adjusted to match video (because the framerate of the movie does not match the framerate of the timeline), then its sound pitch will change. This can be compensated for by resampling, but will thereby add processing load to the server. It is better to create time-matched media.

### Morph (Geometry)

Morphing enabled for a warp/geometry resource will transition the shape of it smoothly from any previous geometry shape on the timeline into the selected geometry shape by the start frame of the selected resource. With Morphing disabled for a specific geometry resource, the shape will 'ping' in one frame from any previous shape to the specific geometry's shape.

### Copy Resource

copies the selected resource on this server to all in the current server Group, or to all connected servers. Resource (a) on layer (b) of timeline (c) on server X, is copied to layer (b) and timeline (c) of server Y. Remember that a Resource is a reference to a real item on a server, with overlaid parameters dictating how, and how much, it will be played. Therefore the media item referenced must also exist on the servers to which it is being copied.

### Concatenate [Left or Right]

All selected resources will be laid end to end with no gaps on the timeline. **Left** will leave the leftmost resource and move all others in line to its right. **Right** will leave the rightmost resource and move all others to its left.

### Goto

on the selected resource, go to its start, middle or end.

### Align

**Left:** moves the start point of all selected resources to the start frame of the leftmost resource.

**Right:** moves the start point of all selected resources to the start frame of the rightmost resource.

**To Cursor:** moves the start point of all selected resources to the current timecode (cursor position)

**To Next Marker:** moves the start point of all selected resources to the start frame of the next marker (if any) on the timeline

**To Previous Marker:** moves the start point of all selected resources to the start frame of the previous marker (if any) on the timeline.

## Markers

---

There are two kinds of control markers: those placed on the timeline layers, and those that go in the timing area.

**Timing markers:** Load File; GUI Beep; Marker; GoTo; Loop and Stop.

**Layers markers:** Global Var; Section; Sequence; Placeholder and Comment.

➤ See [Delta Supported Media and File Locations](#) <sup>(39)</sup> for explanations of terms.

Timing markers can be added to the timing area to mark key points of the timeline – you can add them precisely by moving the cursor to the desired time, then pressing Ctrl+M. Otherwise, drag a marker from the Controls selection of the resource pool onto the timing area at the bottom.

Ctrl+M will first open the editor dialog, otherwise, right-click a marker for properties and actions (or double-click in Main menu > View > List Markers).

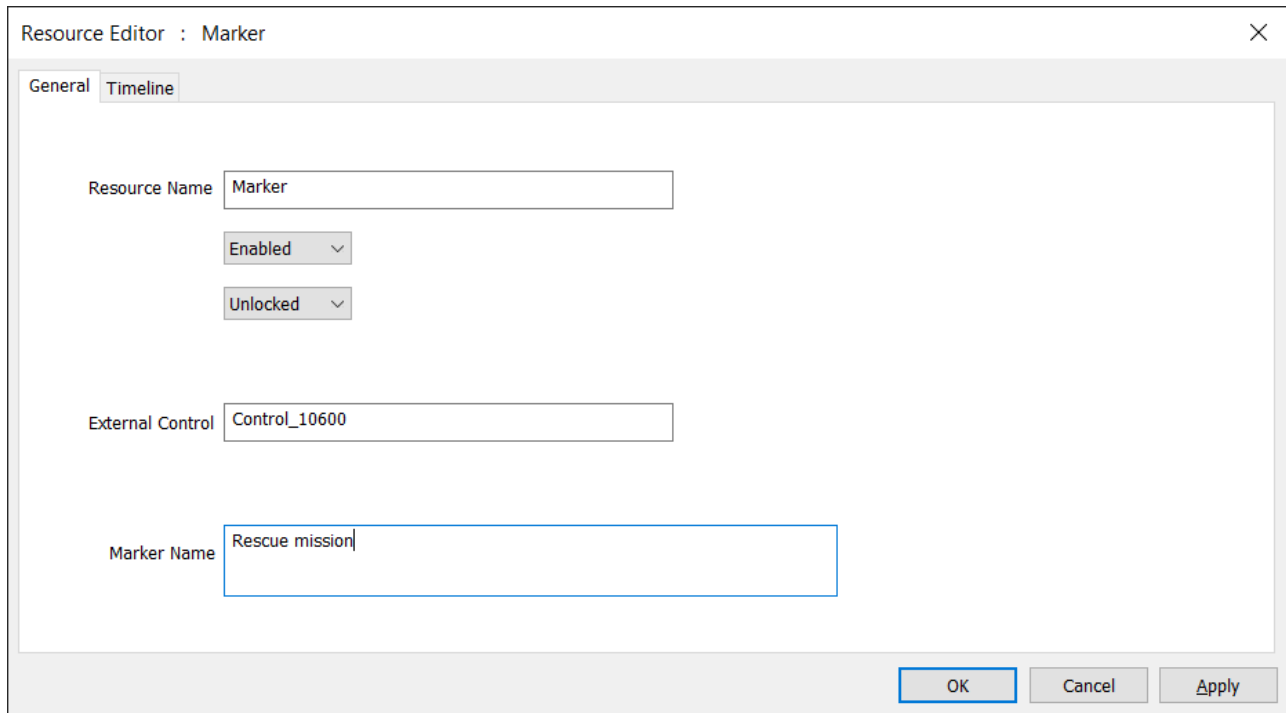

The screenshot shows a dialog box titled "Resource Editor : Marker". It has two tabs: "General" and "Timeline", with "Timeline" selected. The dialog contains the following fields and controls:

- Resource Name:** A text box containing "Marker".
- Enabled:** A dropdown menu currently set to "Enabled".
- Unlocked:** A dropdown menu currently set to "Unlocked".
- External Control:** A text box containing "Control\_10600".
- Marker Name:** A text box containing "Rescue mission".

At the bottom right of the dialog are three buttons: "OK", "Cancel", and "Apply".

By editing the marker, you can change its behaviour, so for example a selected keypress sets the current time to that marker, and optionally play when it is pressed:

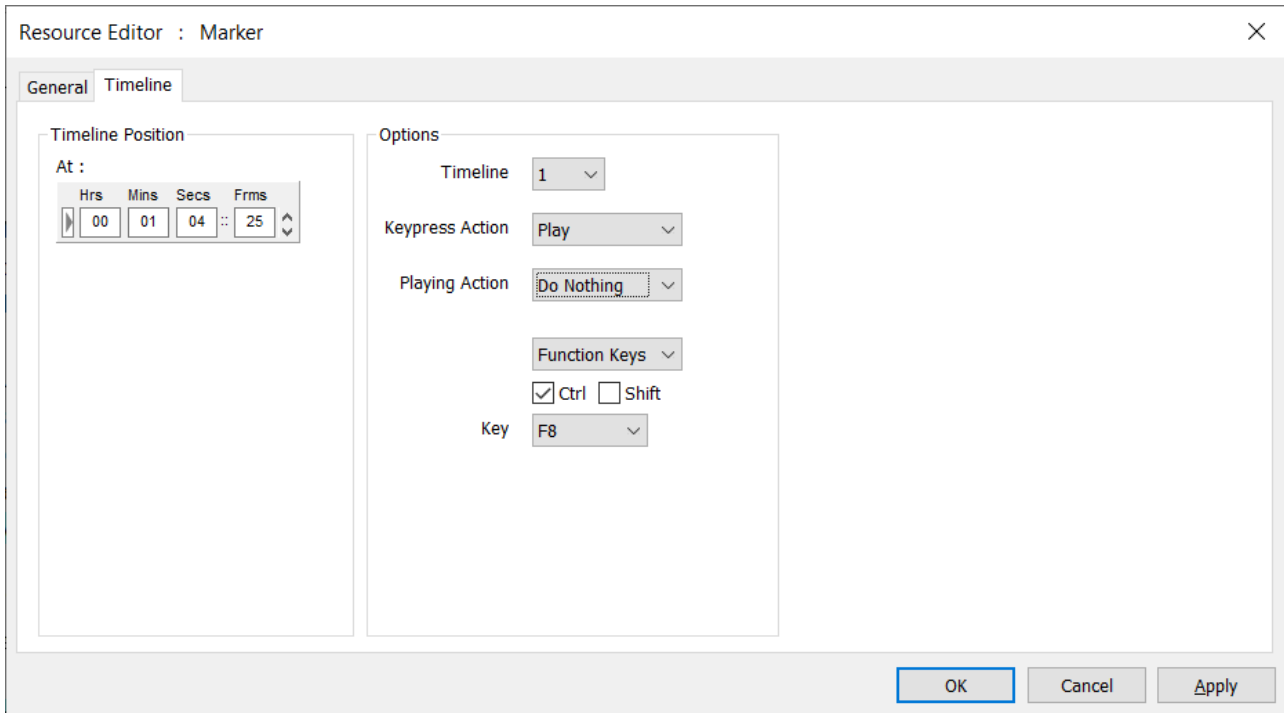

## Resource editor: marker-specific selections

### Key

which function key, if any, is assigned to that marker for quick positioning on the timeline.

### Keypress Action

choose to play or stop after moving to the marker when the chosen function key is pressed

### Playing Action

Choose to do nothing (default) or Stop as the playhead reaches the marker. This option means you don't need a Stop control at the same location as well as a marker to just play between markers.

Control Lines are vertical lines shown beneath resources extending up from the marker at the bottom – these can be turned off with the Layers Area [Layers] button menu *Show > Control Lines*.

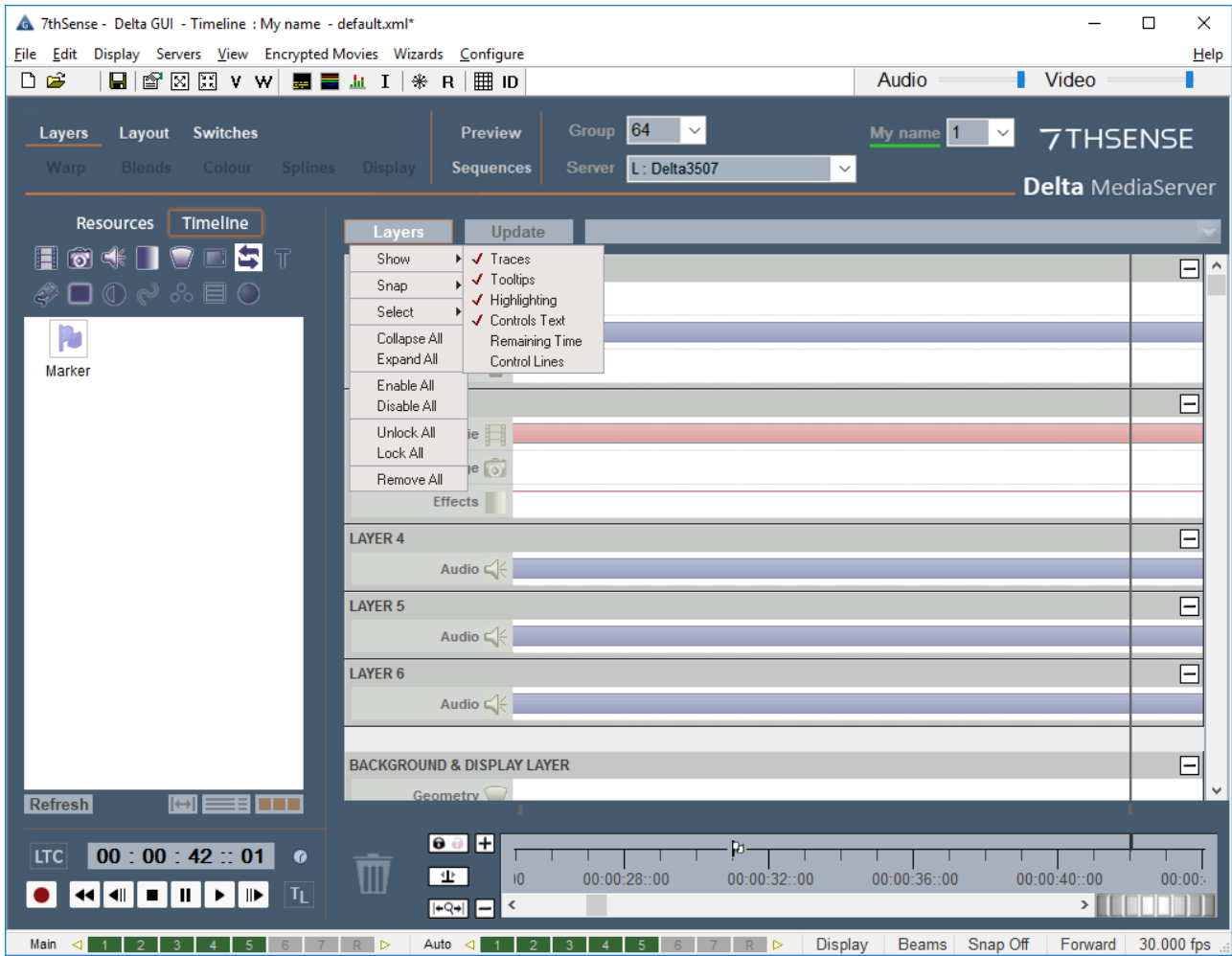



You can also align single or multiple resources to the control lines by right clicking on the resource as shown below, choosing Align, then Next or Previous Marker (or the current time of Cursor).

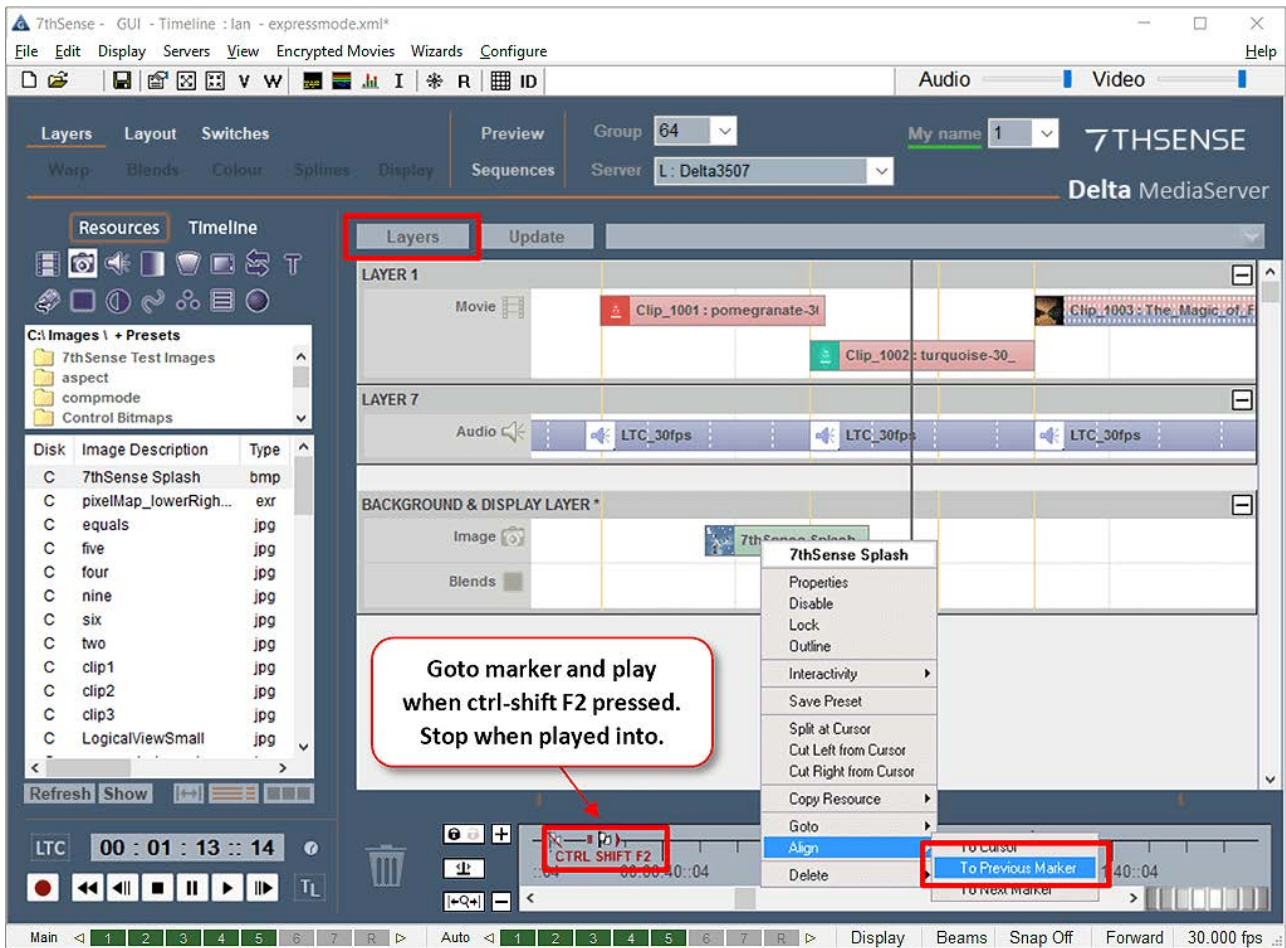

If markers are already in place, then a new resource, when holding Shift as it is dragged onto the timeline, will snap to a marker control line:

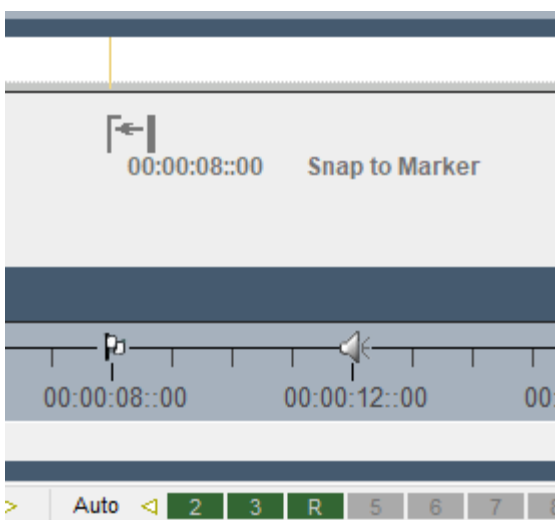

## List Markers

Markers can also be named, and listed from the Main menu > View > Marker List:

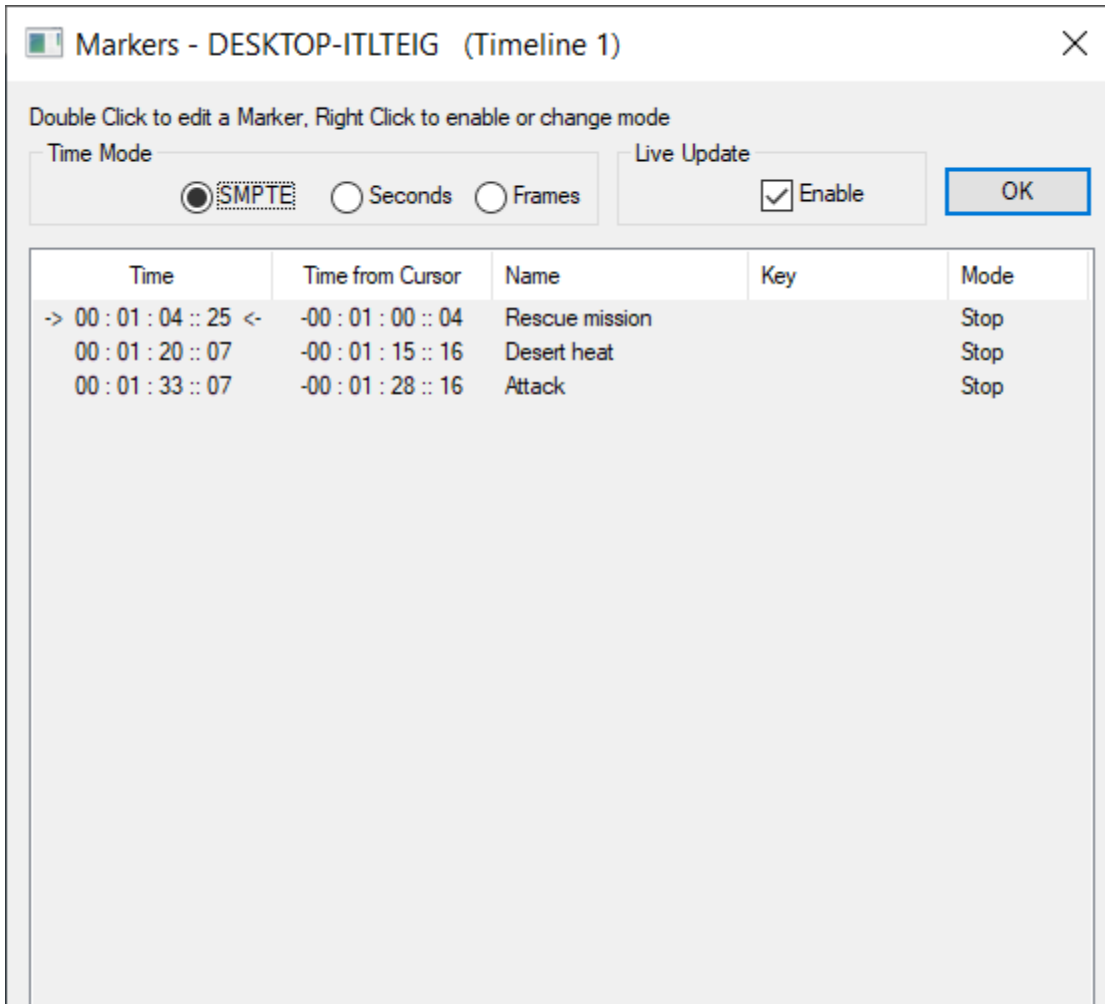

Check Enable to see Time from Cursor dynamically during play. When not enabled, double-click a Marker row to open the Resource Editor. 'Mode' is 'Keypress Action' in the Resource Editor.

## Seamless Looping a Timeline

### Looping Media, Looping the Timeline

You can enable Loop on movie and audio resources, allowing you to drag the length of the resource out beyond its natural length. This will provide seamless looping of that media resource. Images and Web Capture resources are inherently loopable anyway.

If you loop a timeline rather than a resource (i.e. to return to the beginning of the timeline and play all layers again) you may want this to appear seamless, with no black frames between, and with no audio hesitation or clicks. In addition to the settings described below, ensure that the loop control in the timing area is the same as the last frame of the media playing, as follows.

You can drag a loop control into the timing area and right-click to send it to the end frame of the show (Auto End):

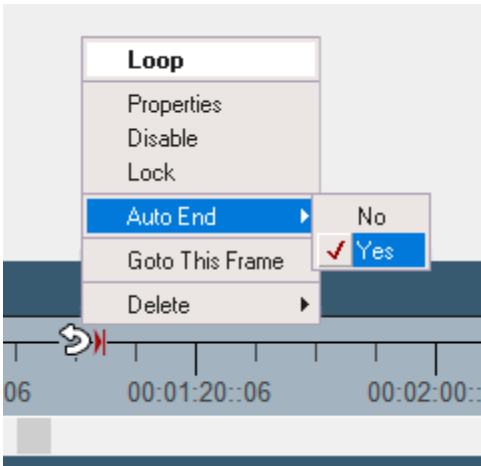

This places the loop in the first frame *after* the last media frame, so now go to the loop control *properties > timeline* and position it back by one frame, to avoid the black frame and/or audio click.

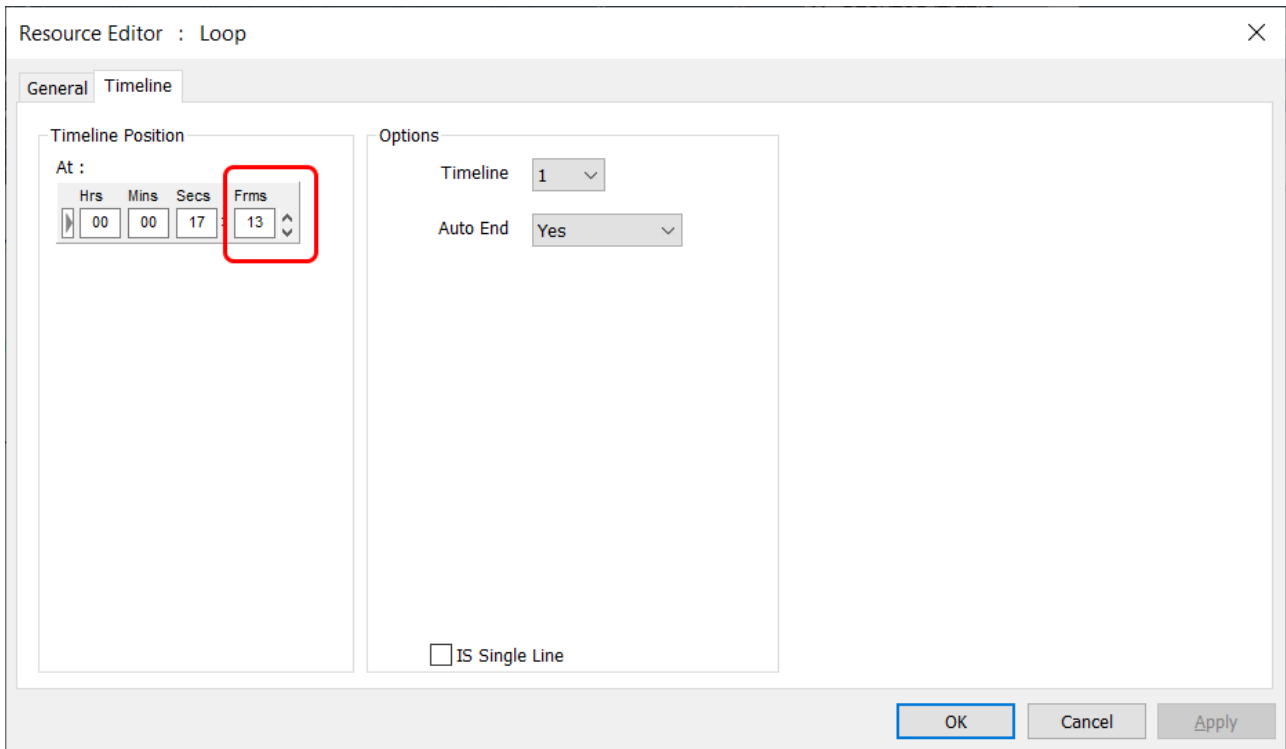

For seamless looping you also need to make a couple of system adjustments.

## Movie Seamless Loop Mode

This movie playback mode must be enabled in the registry (Delta/System/**DisableSeamlessLoop** key = 0). It creates seamless playback of media as well as seamless, smooth transitions from one part of the timeline to another if Goto or Loop controls are present. In addition, external control commands for Gotomarker, Gototime etc., will also transition seamlessly without stopping the timeline as in normal mode.

### Registry Edits

7thSense software uses the Windows Registry extensively, and on occasion we make recommendations for changes.

- Before making any changes, close DeltaGUI and DeltaServer.
- DeltaServer can take up to 10 seconds to fully close in the background, even if it appears that all the Windows have closed. Ensure that Delta has *fully* closed before opening and/or refreshing, and finally editing. The best way to ensure this, is to watch Windows Task Manager > Details list. You will see 'DeltaServer.exe' in this list if DeltaServer is still running. If it won't close for any reason, you can right click on it in the list and choose 'End Process Tree'.
- Make a note of any setting before you change it, in case you want to change it back.
- Only make the changes as recommended and only to those registry keys.

*The difference is shown in this example: Movie 1 is in scope playing, and a Goto control comes into scope which jumps to the start of Movie 2.*

### Non Seamless Loop

The timeline stops for 1 frame, jumps to Movie 2 and Cues, then Plays (<0.5 s delay)

### Seamless Loop

The timeline jumps to Movie 2 and plays immediately (no delay).

In Seamless loop mode, there are some things to be aware of. Any timeline control jump (Goto, Loop etc.) is pre-planned during playing the show, but for external control versions (GOTOMARKER, GOTO TIME etc.), there is some delay from an external control command to GOTO a timeline location, while the new seamless transition is initiated. In non-seamless loop mode, these external commands happen immediately, but without a seamless transition.

- With seamless looping enabled, the server pre-caches clips that we will be jumping into via a GOTO, a loop or or via an external control command GOTOFAME.
- The amount of time that the server is given to cache ahead is set with the Preroll Frames setting in the *Config > Preferences > Timing* section.

- The minimum duration for video only is 5 frames – for codec or audio we would recommend 100-200 frames, depending on the power of the server.
- You cannot loop seamlessly back into the same audio track that is currently playing.

## Audio Seamless Joins

When audio media are butted together, for truly seamless joins the following audio clip needs to start on the next clock cycle after the preceding clip ends. This is achieved by cueing the following clip.

This also has to be set in the registry (Delta/Hardware/**AudioSeamlessJoins** key = 1).

## Timing Controls Distribution

---

When [Seamless Looping](#) <sup>(290)</sup> is being used, any timing controls between Leader and Followers must be synchronised precisely. Whilst this could be done manually, it is best done using Delta's timing controls distribution (TCD).

### Registry Keys required to Implement TCD (for every server in the group)

First you need to set the [ports](#) that TCD will use to communicate by TCP and UDP.

Ensure DeltaServer is closed. In the registry, find \SOFTWARE\7thSense\Delta\System:

**DisableSeamlessLoop:** this should already be 0.

**TimingControlsDistributionBasePort:** This must be the number which, when added to the server group, gives the required port.

*example:*

required port no. = 2078  
Delta server group = 16  
TCD base port = 2062

The UDP port will automatically be set as TCP port + 1 (in this example, 2079)

**TimingControlsDistributionEnabled:** 1

Restart DeltaServer.

## The Server Group in DeltaGUI

In this example, we have two servers in Group 63. On the Leader timeline a loop marker has been added to the timing area, and when we look at the Follower, we see the same marker visible:

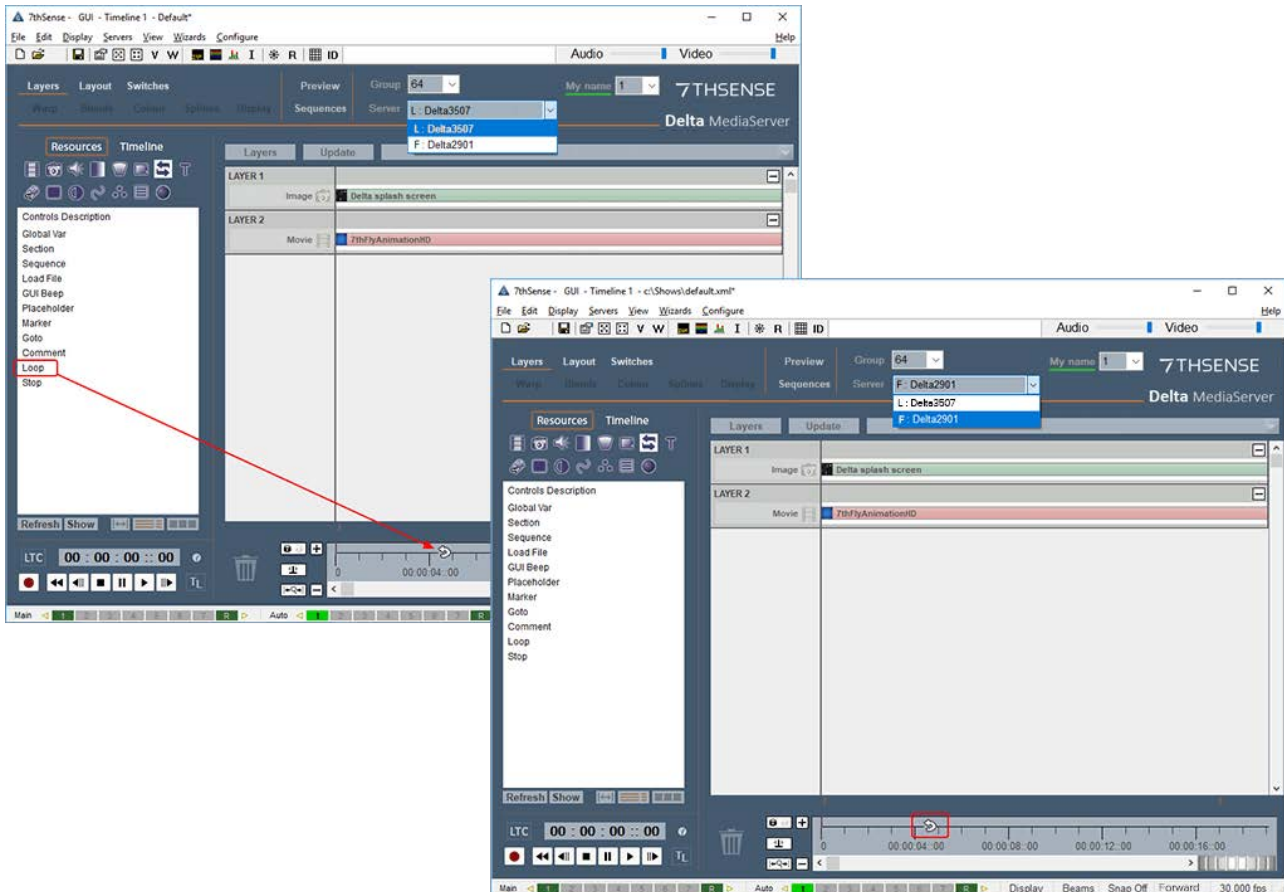

Only timing control [Markers](#)<sup>285</sup> can be added to the timing area:

- If a timing control is moved or deleted from the Follower timeline, it will not be reinstated unless the Leader server control is touched.
- The Leader timeline show must be saved to retain the controls.
- The Follower timeline can be saved, but if both are closed and reopened, the Leader controls will be reasserted on the Follower.

If any server is removed from or added to the group, there will be an alert to restart that server:

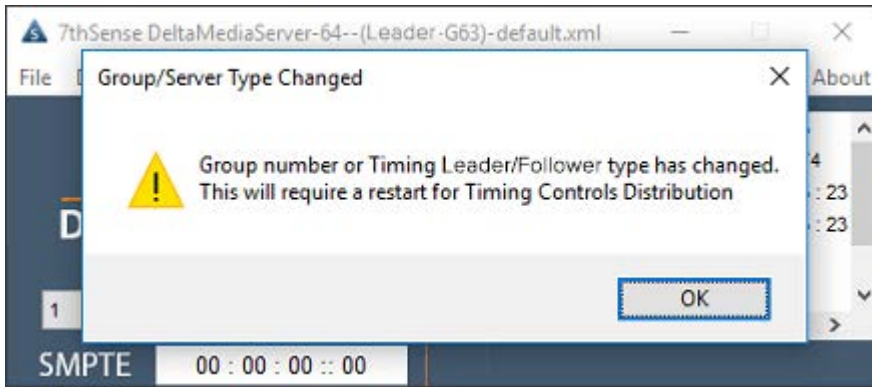

## Disable, Lock or Delete Media

To **Disable a resource** on the timeline, simply Right-click on the resource and select Disable (or Enable if it is disabled).

You can also select its properties and choose Disable from the General tab.

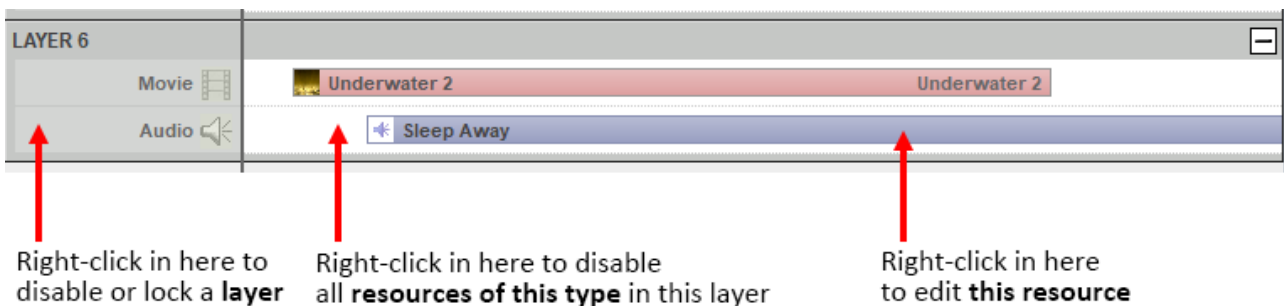

Disabled resources act as if they are not present on the timeline, and are drawn in light grey.

To **Disable an entire Layer**, right-click on the Layer area outside a resource, and select Enable or Disable.

From this menu, you can also **Delete an entire layer**, collapse or expand a layer, or insert padding space or cut space at the current cursor position.

To **delete a resource**, Right-click on the resource and select either Delete this Resource or Delete all Resources of this type on the layer. You can also drag the resource to the trashcan.

**Locked** resources behave as normal, except you cannot select them or move them in DeltaGUI until unlocked. A lock icon  shows up when this is active.

To **Lock** a resource or layer, right click and choose lock / unlock.

To **Split** a Movie, Video Capture, Text resource or Audio file, right click and press Split. This will create two resources where the timeline cursor is located which are contiguous in time, so until you move the second movie / audio file, it will still play with no gap. This function can be used to align separate parts of movies or audio files to help in synchronising content.

To **Cut** a visual resource, choose **Cut Left from Cursor** to remove all parts of the resource to the left of the cursor, or **Cut Right from Cursor** to remove parts to the right.

To **Align** resources, right click a single resource or rubberband around multiple resources, then right click and choose align left, right, To Cursor, To Next Marker or To Previous Marker.

To **Concatenate** resources, rubberband around multiple resources, then right click and choose Concatenate left or right.

## Outline Media

---

Outlining is a temporary moving edge around a resource which can be used to locate a resource onscreen in a complex show, or simply show the edge of (for example) an image used as a mask.

To **Outline** a resource on the timeline: right-click on the resource and select 'Outlined' or 'No Outline'.

You can also use the right click context menu on a single or multiple selected resources to Outline or Clear Outlining.



## Presets

You can save a resource from the timeline as a preset, with all its configuration saved so that later, you can drag that preset back onto the timeline with all parameters intact.

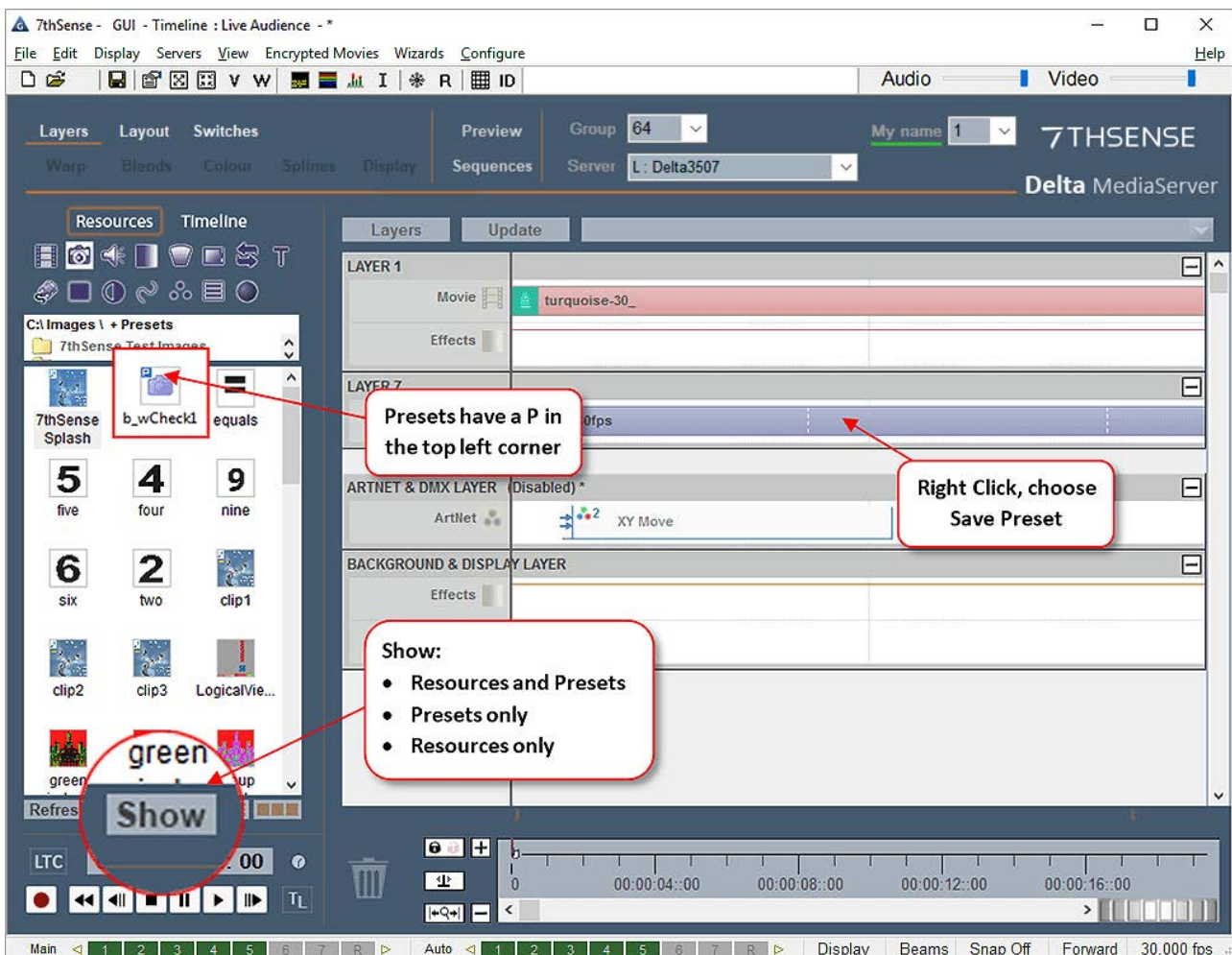

Presets are available for Movies, Images, Audio, Effects, Splines, Serial Events, Text, Controls, Containers, Video Capture and are stored in the C:\Presets folder as CLP files. These are shown in the resource pool with a small blue P in the top left corner.

You can delete a preset from the resource pool by right clicking in the resource pool and selecting Delete.

You can filter the resource pool to only show presets, only non-preset resources or all presets and resources by pressing the Show button in the resource window and choosing that option.

Geometry, Blends, Colour, Splines all still save their presets (in the relevant Config page) to the relevant folder on the C: drive (e.g. C:\Blends for blend resources).

## Using Media Resources

---

Some default resources will already be on your Delta server(s). You will import and create your own, manipulate them and create shows. These can be complex, and you may have a great many resources. The Resource Finder (Ctrl+F, or *View > Resource Find*) will help you. Here, you can search all resources, filtering by timeline, type, and name.

The Resource Editor is displayed when you double-click any resource on the timeline, or right-click and choose its 'Properties'. Several tabs are fairly common to many resources, but each type has its own tab. These links will take you to descriptions of the properties for the main assets:

- [Movie Files](#) <sup>309</sup>
- [Audio Files](#) <sup>312</sup>
- [Video Capture](#) <sup>314</sup>
- [Spout capture](#) <sup>316</sup>
- [Web Resource](#) <sup>319</sup>
- [Text](#) <sup>334</sup>
- [Keying \(Chroma and Luma\)](#) <sup>338</sup>
- [Art-Net and DMX resources](#) <sup>340</sup>

## Resource Finder

---

Menu > *View > Resource Find* or simply Ctrl+F. This dialog can be used to find resources on the timeline by typing in the full or partial resource name, then pressing Go.

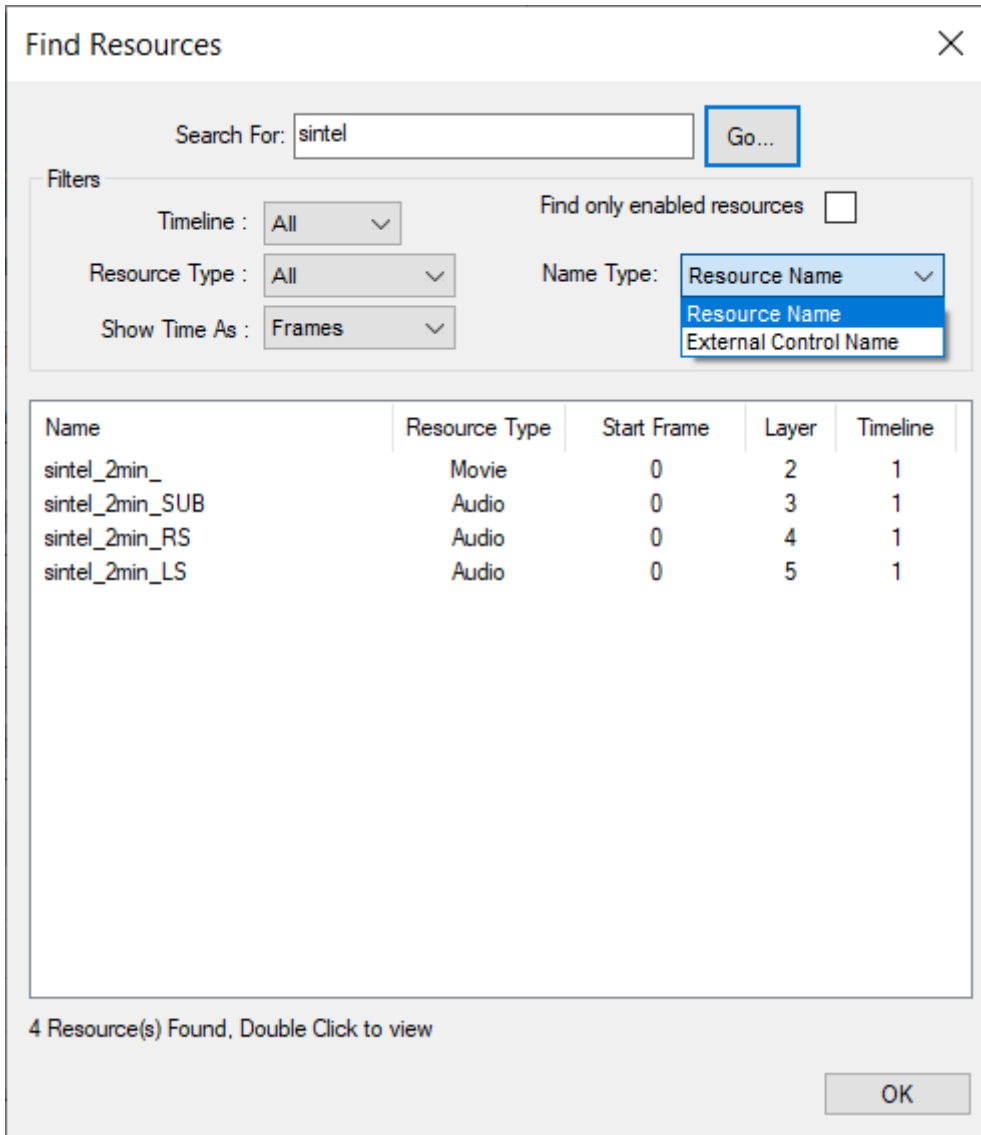

Resources will be listed – double clicking any of them will set the timeline cursor to that resource and layer in DeltaGUI.

You can optionally search one or any timeline, for only enabled resources, by resource name or external control name or by resource type.

## Timeline Summary

Choosing Timeline Summary from the View menu shows a dialog which has a text summary of all the resources on the timeline. This can be sorted by start position or layer.

The summary can be copied to the clipboard for offline review using the Clipboard Copy button.

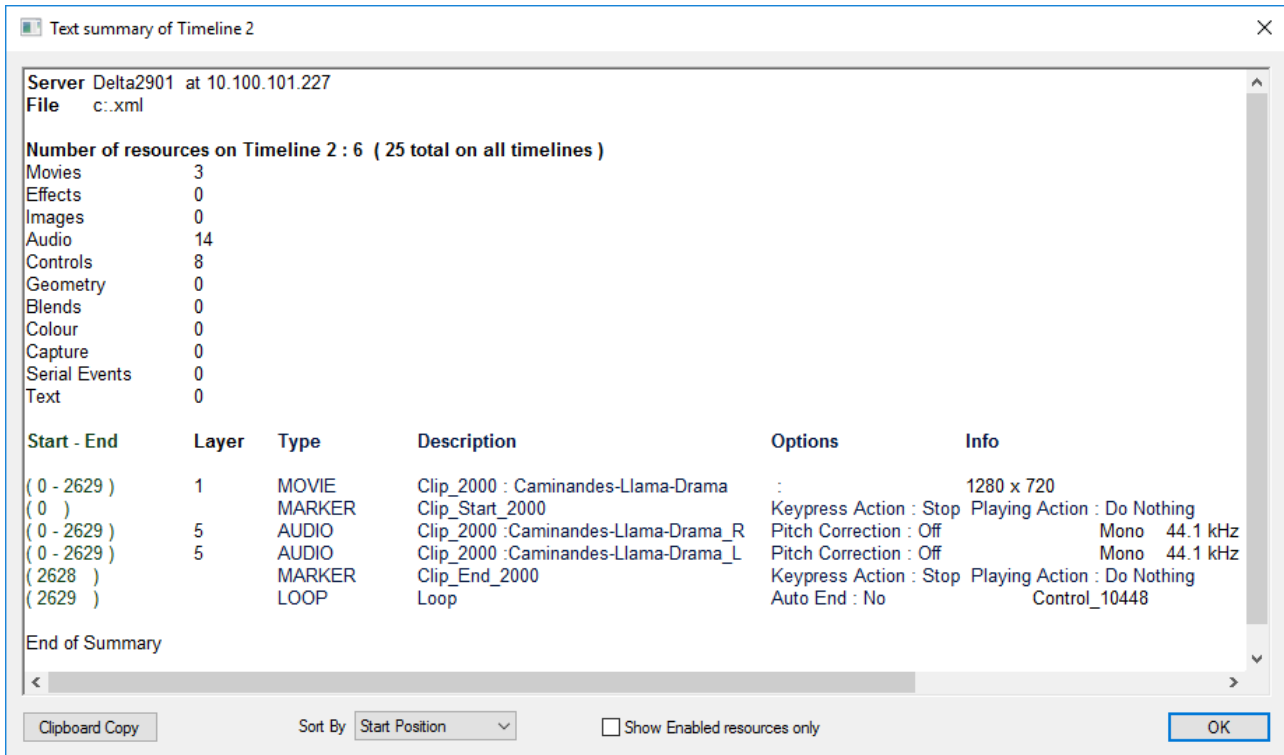

Any problems with an individual resource will be highlighted beside the name and a list of resources with errors will appear at the bottom of the page.

## Ingesting (importing) Resources

Large media files are simply copied from a source drive to the required server, into the appropriate destination folders as described under [Delta Supported Media and File Locations](#)<sup>39</sup>.

Smaller resources such as shows, meshes or images, may be required on more than one server, or all in a group, and can be copied and distributed using the Ingest Resource Wizard.

From the DeltaGUI PC, *Wizards > Ingest Resource File*, you can ingest files (save on remote servers).

### Choose Resources

Press the Add File button to choose OBJ, XML, Audio and Images files to the list.

Press the Clear button to remove all files from the list.

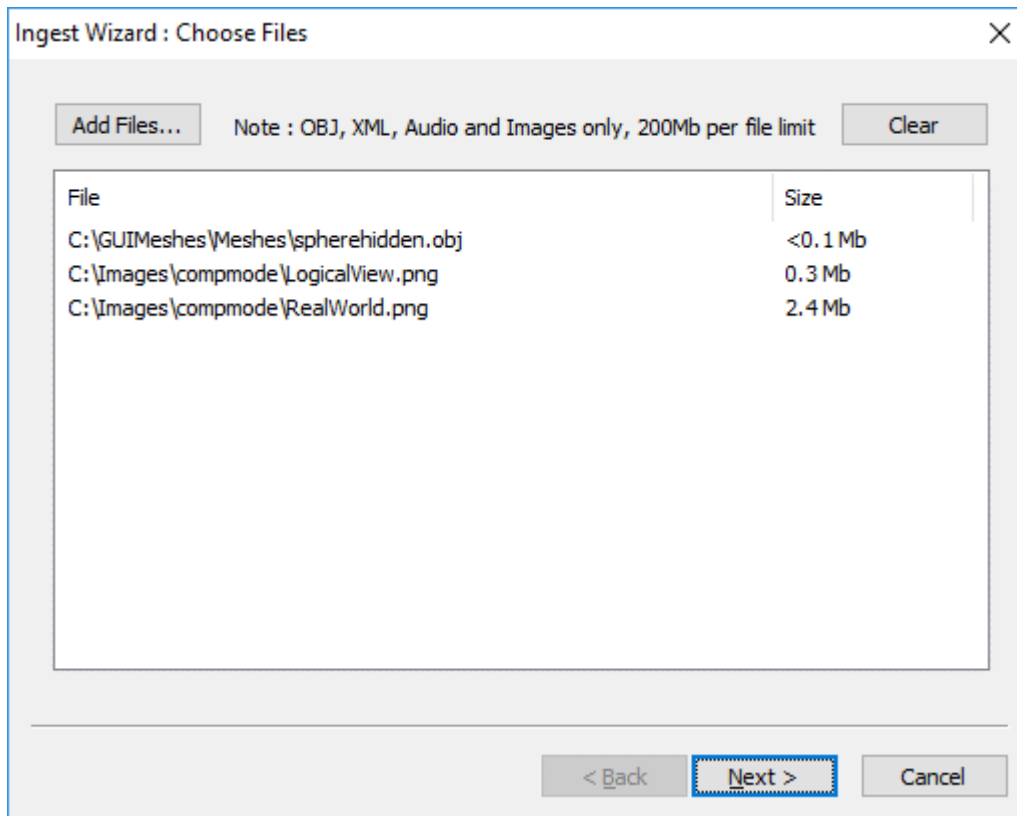

## Choose Destination

In a similar set of choices to the Copy Timeline dialog above, choose a single server, multiple servers, a group or all servers to receive the files.

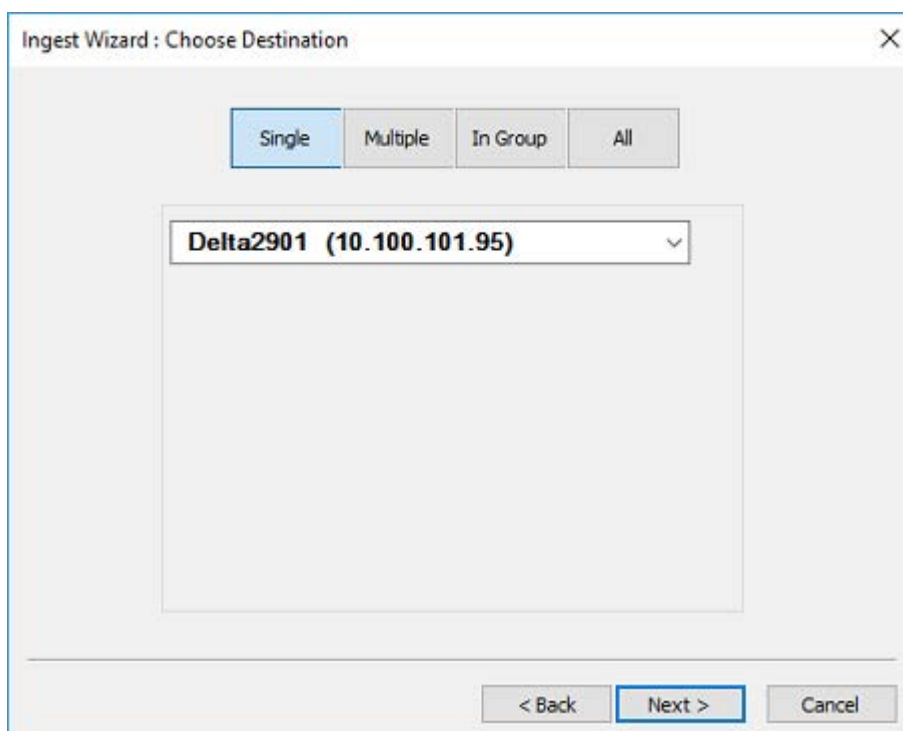

Click 'Next' to process.

## Process Files

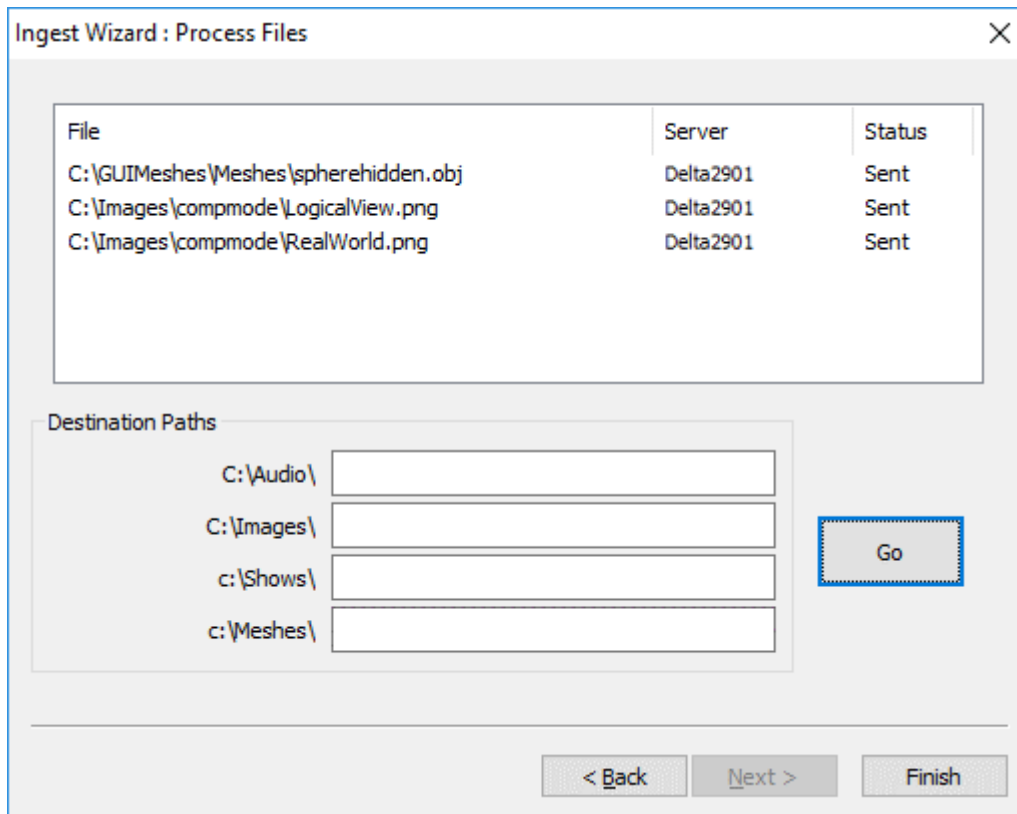

Click 'Go', to send the selected files to the selected servers. 'Sent' will show when complete.

Note that in this dialog, you can enter a subfolder for each resource type. Leaving these boxes blank will place resources in the default root folders for their file type.

There is a size limit of 200 Mb per single file, and currently only images, audio files, OBJ mesh files and XML / XDL files are supported.

## Configuring Resource Properties: the Resource Editor

Media resources have configurable properties. You can access these by double-clicking on the resource in the Layers Area, double-click on the resource name in the Resources Area (timeline selected), or right-click the resource and select Properties.

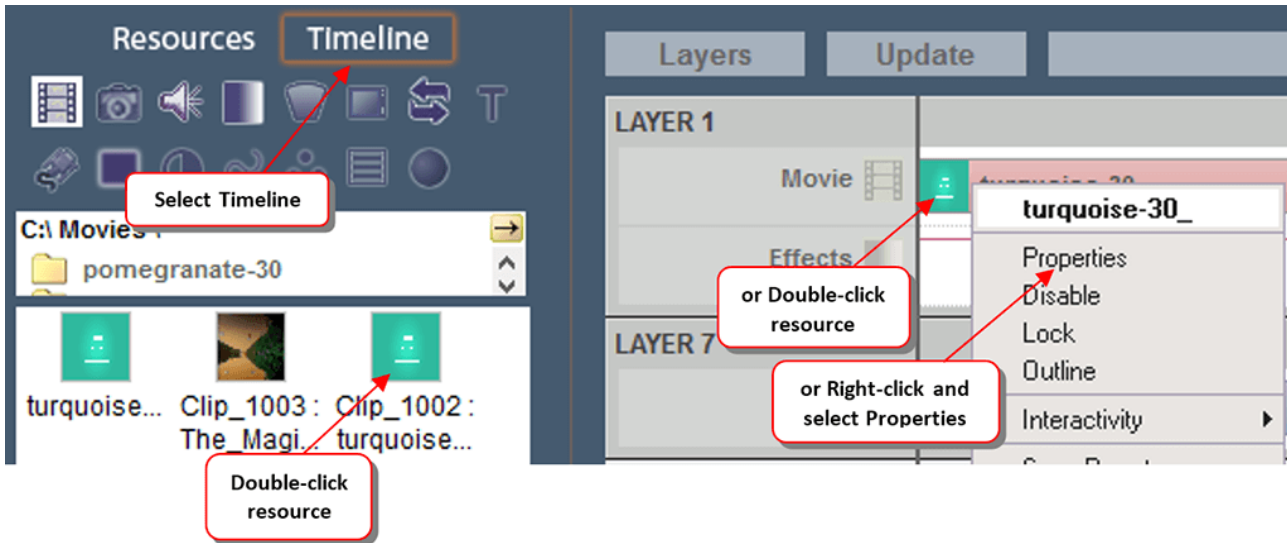

After selecting properties, the Resource Editor is displayed.

## Resource Editor: General

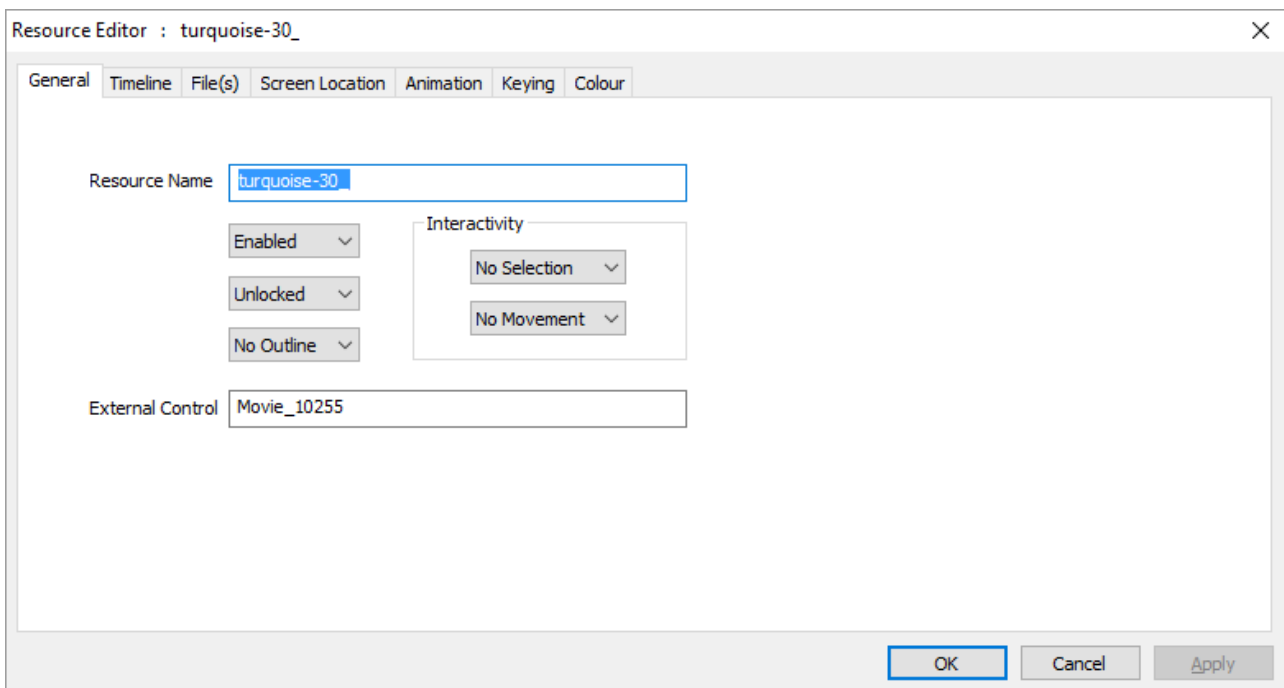

On this tab, you can change the name of the resource, and whether it is enabled or disabled.

Disabled resources will not be visible in the show, and are drawn in light grey on the timeline to indicate this.

**Outlined** resources will show a moving edge to highlight that resource.

**External Control name**

use the default or edit this to a more memorable name for use by external control commands.

**Interactivity – Selection**

allow this resource to be used as a button on the playback window

**Interactivity – Movement**

allow this resource to be moved playback window

**Note:** interactivity is globally configured in Configure > Preferences > Interactivity

## Resource Editor: Timeline

The timeline configuration page is the most used resource-editing page for any resource, where you can set important parameters such as Layer, Position on the timeline etc.

Resource editor options for an image or movie (different options are presented according to the media type):

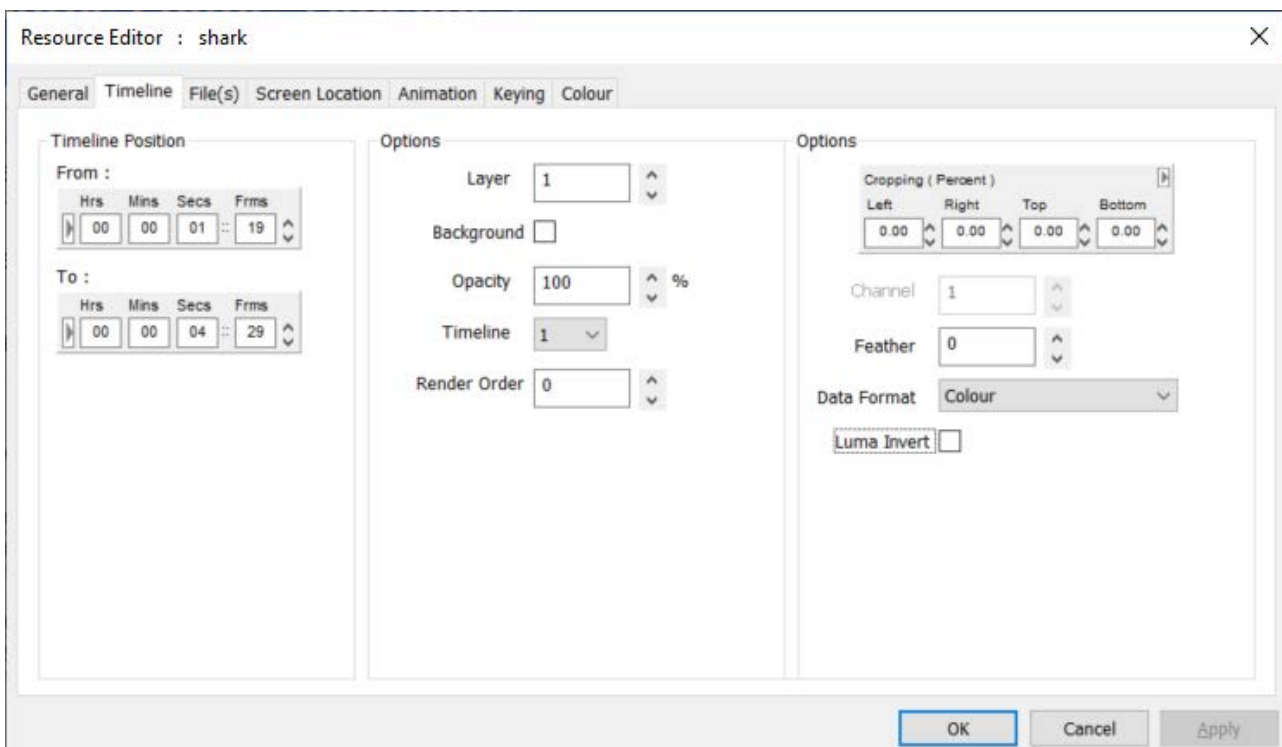
**Timeline Position**

The timeline **Position From / To** values can be set using the dragging technique mentioned above, or entered manually here.



**Layer**

You can change the **layer** of this resource, from 1-250, or place it on the background layer, which is below all other layers (see [Layers Area](#)<sup>81</sup>).

**Background**

Checking this box puts the resource on the background layer, behind all others. Other options (e.g. Channel) then become available.

**Opacity**

The static **Opacity** can be changed from 100% to 0%, for example, if Layer 1 has an image with 75% opacity, a layer below it will show through by 25%.

**Timeline**

Shows which timeline this resource is on.

**Render Order**

Available for movies, images, capture and text resources, changing from 0 will visibly place the resource on a separate sublayer from other resources on that layer. Sublayers will be ordered 0, 1, 2 ... Render order is important for DeltaRealTime users with data formatting media

**Cropping (% or Pixels)**

For **Images, Video Capture and Movies**, you can specify a percentage amount or pixels of cropping on each edge to remove unwanted edge areas. You can select to enter the values as Percent (of resource width) or in Pixels directly.

Cropping crops the media, which then stretches to refill its allocated screen location, either full-screen, or the dimensions set (Screen Location tab).

Note that swapping between modes will reset values to 0:

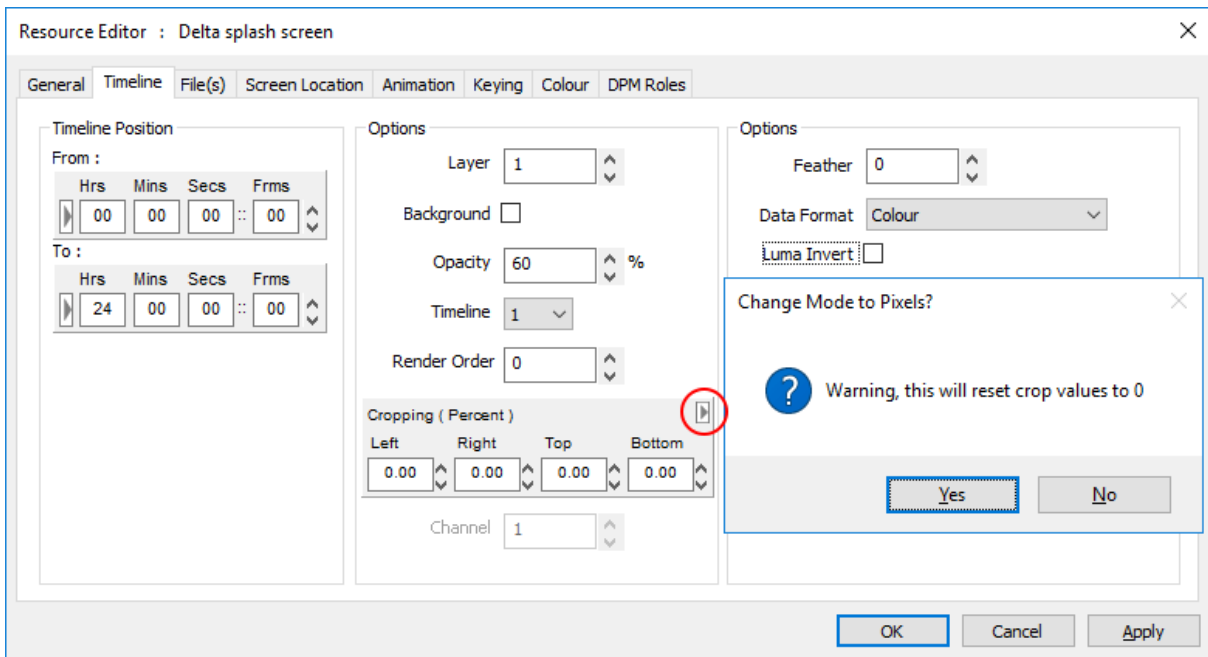

### Channel

**Background layer only**, which channel the effect (e.g. geometry, colour or blend) will affect. Note that if the channel is disabled, nothing will be seen in the playback window for this resource.

### Feather

**Images** only, a percentage amount of softening around the edge of the image to remove any jaggy edge.

### Data Format

For **Movies, Images or Video Capture**, these resources can be set to be a luminance, depth (or combination) modifier instead of a normally drawn resource. This allows any visual resource, such as movies, images, or capture sources, to be used as transition effects, or to define mathematical operations between sources for composition.

**Colour:** standard resource, no luma or depth modifier.

**LumaKey:** use this resource as a luminance modifier. In this case, any resource on that layer will be multiplied with the resource set to luma-key in one of these modes.

**Depth** and **Stencil** are resource features used in **DeltaRealTime**, the compositor for merging real-time media assets and pre-rendered playback media. For a full explanation of how to use DeltaRealTime, see the separate User Guide.

**Depth (Red / Green / Blue / Alpha):** use this resource as an 8-bit depth modifier for DeltaRealTime applications. In this case, each pixel of any resource of that layer will be checked against this depth buffer, and a depth buffer of a layer below to determine which pixel should be shown. The pixel closest will be shown.

**Depth (RGB):** Up to 24-bit depth (8-bit if B alone, 16-bit if G and B, 24-bit if R,G and B).

**Stencil (R+) G(x):** identify this resource as a **DeltaRealTime** stencil.

Any Red pixel in the stencil resource indicates the current colour resource should be added to the existing frame contents (e.g. for illumination, or light blooming).

Any Green pixel in the stencil resource indicates the current colour resource should be multiplied to the existing frame contents (e.g. for semi-transparency, or casting shadows).

**Notes on stencil:** the Red or Green stencil value will also be multiplied across all colours of the colour resource to allow attenuation of the source prior to addition or multiplication.

Blue in a stencil is alpha.

### Luma Invert

Invert the sense of the luminance modification.

### Morph

**Geometry** only, whether to morph from the previous geometry or simply switch in this geometry at the start position.

### Direction

**Fade / Transparency** resource can be Up or Down.

### Panning

**Audio** resources, pan the audio from -100 (full left), through 0 (equal left and right) to +100 (full right).

### Pitch Correction

For **Audio** Files, if you use Play Speed compensation to match an audio file at a different frame rate to the timeline's frame rate, the pitch will shift up or down accordingly. Enable Pitch Correction to stop this change in pitch, but still change the length of the audio file.

**Note:** this requires some CPU processing, so check that frame drops are not caused by overloading the CPU.

### Go to Frame

Goto timeline control only, which frame to go to, also the Mode of Stop or Play is shown here for this resource.

### Freeze Group

Yes / No. Selecting Yes for this video capture device will allow it to be frozen from the toolbar freeze button. Note that all instances of this video capture device on the timeline are frozen together.

### IP Address and Port

Only for **Serial Event** files which have had the Telnet section added. Set any valid IP Address

and port here, the serial event string is sent out as normal in a UDP packet, instead of to a COM Port.

### Video Mode

For **Video Capture** devices, choose the video resolution, refresh rate and compression from this list.

### Repeat Frames

For **Serial Events**, turn on Repeat and this value sets the frame interval between repeated instances of this serial event.

### Repeat Count

For **Serial Events or Splines**, turn on Repeat and this value sets the number of times this event will be repeated (1 = repeat once more on timeline).

### Eye

For **stereo** content, select the eye (left or right) or even left-right and top-bottom configured content.

### Ping-Pong

For **Splines** with a repeat count greater than 1, either restart from the start of the spline, or change direction on each repeat.

### Forced W and Forced H

For **capture** cards, force the Input resolution to these values (where the capture hardware supports this feature).

### Fixed (Yes/No)

For **geometry or blends** on the background, if Fixed, will auto-reset to frame 0, if not Fixed, you can set the start frame as normal.

### H Resolution

For **Web Controls**, the rendered width of the page.

### V Resolution

For **Web Controls**, the rendered height of the page.

### Warp Mode

For **geometry** on the background layer, choose Normal, Converge Red or Converge Blue.

### Render Width and Render Height

For **Notch** input capture, set the rendered resolution to these values.

## Markers Only

### Key

which function key, if any, is assigned to that marker for quick positioning on the timeline.

### Keypress Action

choose to play or stop after moving to the marker when the chosen function key is pressed

### Playing Action

Choose to do nothing (default) or Stop as the playhead reaches the marker. This option means you don't need a Stop control at the same location as well as a marker to just play between markers.

## Resource Editor: Movie Files

The Files configuration tab for Images simply shows the full path to the file. For Movies resources there are configurable items as below:

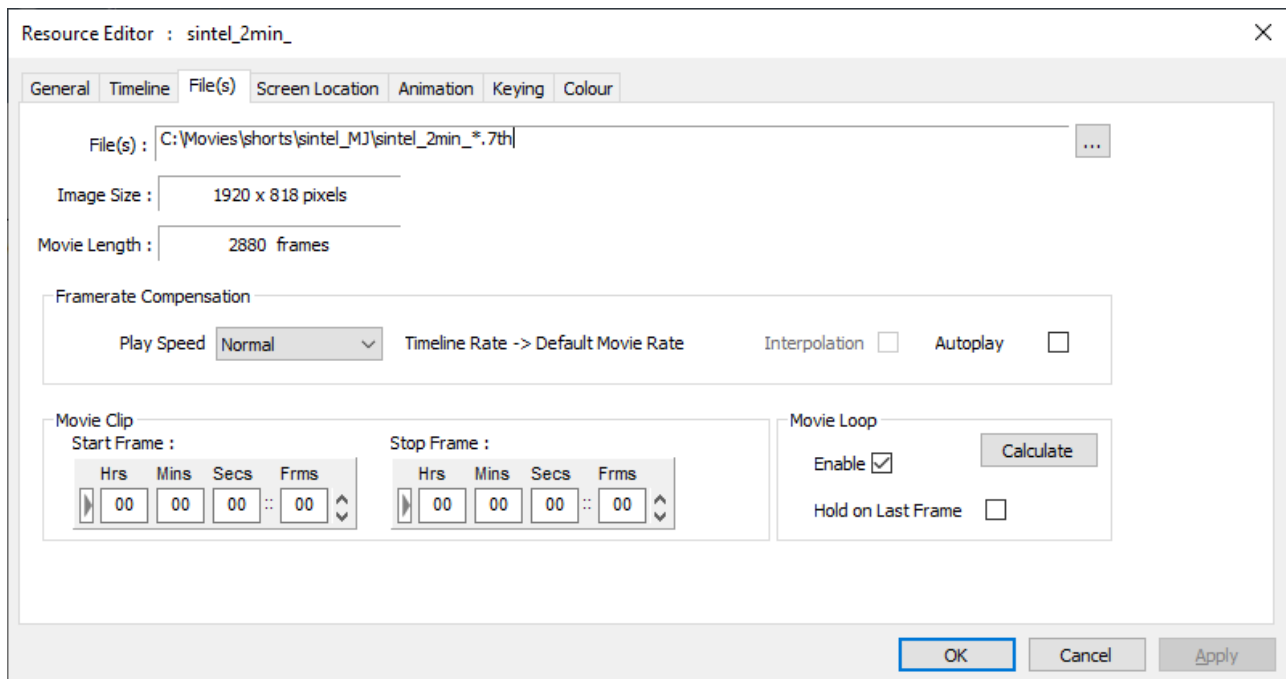

The  button allows manual editing of the file details.

The **Audio** checkbox (appears with a codec resource) allows you to specify if audio contained in a movie file should be played.

## Video Framerate Compensation

The **Play Speed** allows you to perform video framerate conversion, for example, playing a 24 fps movie at 25 fps, but maintaining the right movie length in time.

Since Delta gets its timing from the graphics card refresh, ideally, this should always be set to a multiple of the movie framerate, so for example a 24 fps movie would have the graphics refresh set to 48 Hz or 72 Hz (the lower value is preferred).

If this is not possible, you could set the graphics refresh to 50 Hz, so now, playing a 24 fps movie at 25 fps makes it  $25 / 24$  too fast. To correct this, choose the Play Speed of 24->25 fps.

To perform this conversion, frames must be dropped or shown twice in order to maintain the correct rate. This may lead to disturbing jumps in the movie, but this is dependent on the movie content and the difference between movie actual and desired rates.

To minimise the size of frame drops, set the timeline rate to a higher rate, so in the example above, choose a 50 fps timeline rate, and enter the custom conversion rate in the box provided:

Actual Movie rate	= 24 fps
Graphics Refresh	= 50 Hz
Timeline rate	= 50 fps
<b>Movie Custom Ratio</b>	<b>= <math>24/50 = 0.48</math></b>

## Movie Interpolation

If you have to use video framerate conversion, for example a 24 fps movie on a 30 fps timeline, you can turn on Interpolation, where extra inter-frame information is created in realtime based on the time error at that point to improve the smoothness of motion.

## AutoPlay

Enable this to make the movie autoplay – as long as the playhead is in scope with the movie, the movie is playing, even if the timeline is stopped.

## Movie Clip

The **Start Frame** is that frame number on disk that you want to start using, so for instance, if set to the above example of 100, the first frame shown will be frame 100, wherever on the timeline you placed this resource.

The **Stop Frame** is that frame number on disk to stop at. Setting this allows you to loop the movie from a start frame to a stop frame.

**Example:** The Start Frame on this dialog is separate from the Timeline Position value on the Timeline tab, so for example:

- 300 frames found on disk for sphere.tga (sphere\_0001.tga, sphere\_0002.tga etc.)
- Position the movie at frame 5000 (Timeline Position = 5000 to 5299)
- Set the start frame to 100 (Timeline Position is now 5000 to 5199), starting at sphere\_0100.tga onwards
- Press Play

The timeline advances until it reaches frame 5000, then the 100th frame (sphere\_0100.jpg) is shown at 5000, 101st frame at 5001 and so on for 200 frames.

From Delta 2.6 build 84, movie files beginning other than frame numbered ~00 will show a thumbnail of the first frame found, and display the number of the first frame, in the file Information shown on timeline resource hover, and dialogs where a Start Frame is set.

*Example:* Movie starts with frame 'name\_0140.tga'. Thumbnail of frame 140 is shown and in dialogs, this additional information:

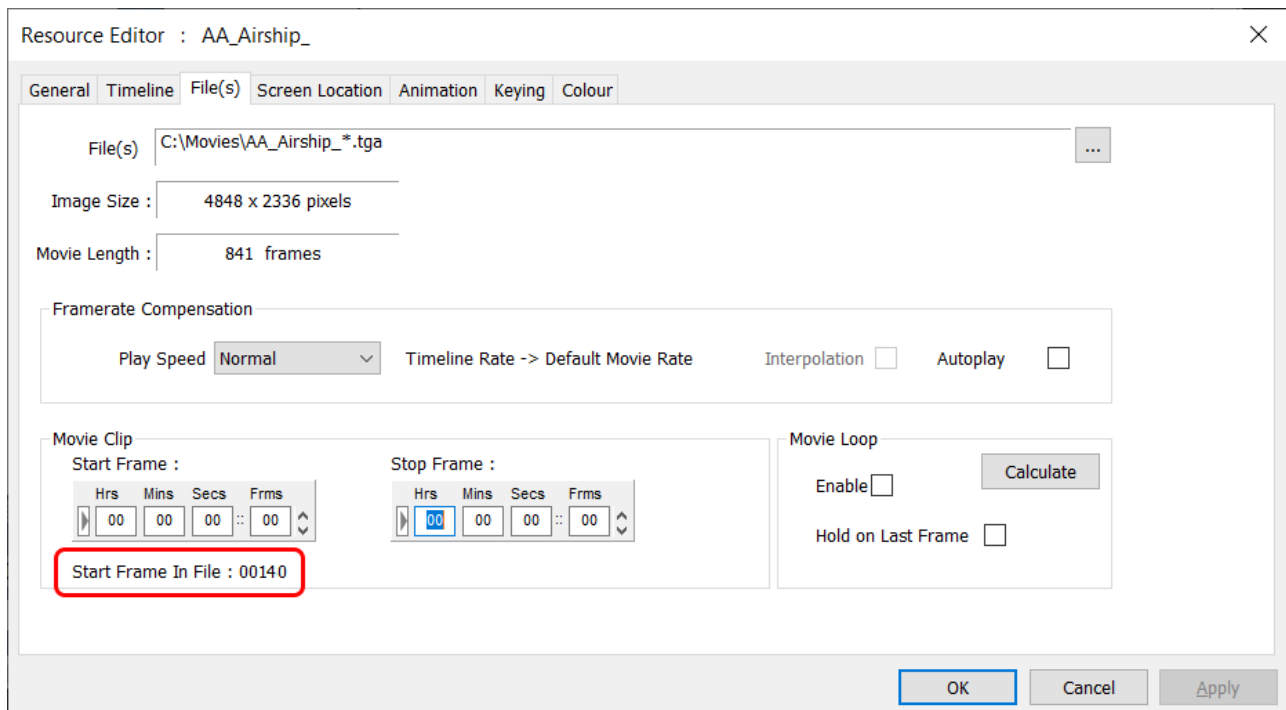

**Note:** 'Start Frame 00' becomes relative, so to stop at stop frame of 50 would mean frame filename ending 'name\_0190.tga'.

## Movie Loop

Select the **'Enable'** checkbox if you want to drag the movie out on the timeline longer than the number of frames – the movie will seamlessly repeat. Use the **Calculator** if you want to work out the length for a set number of loops.

Select **'Hold on Last Frame'** as well, if, instead of repeating the movie from the start, you want to extend the length of play by continuously repeating the last frame until the next timeline play control. **Note** that on codecs with audio, the last frame is held but that audio channels restart from the beginning.

## Resource Editor: Audio Files

For Audio, Play Speed has a dropdown of various audio conversion rates (see below) as well as a custom setting which allows you to type in a speedup factor.

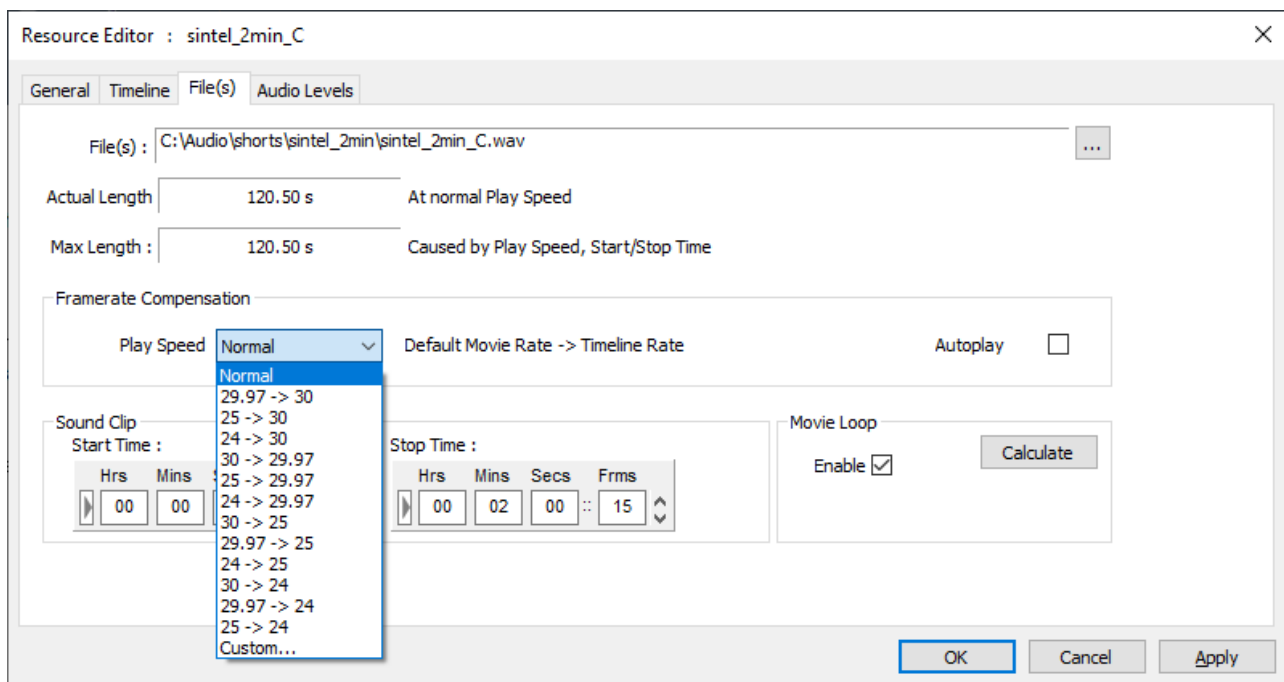

## Audio Framerate Compensation

These conversion rates can be used to compensate, for example, a 24 fps audio track playing on a 25 fps timeline. Without compensating, the audio will run ahead of the video in the example below:

Using the conversion below, the movie will play 25 / 24 too fast, but the audio will stay in sync with the movie:



- Actual Movie rate = 24 fps
- Movie Rate = 24 fps
- Graphics Refresh = 50 Hz
- Timeline rate = 25 fps
- Audio Play Speed = 24 -> 25**

**Note** that the pitch of the audio will be increased by this amount.

**Start and Stop Time** can be used to crop the start or end of the audio file.

The **Loop** checkbox allows you to drag the audio file out on the timeline for longer than the number of frames – the audio will seamlessly repeat. ‘AudioSeamlessJoins’ must be set in the registry to avoid missed clock cycles.

**Autoplay:** Enable playing of this audio independently of the play mode of the timeline.

### Audio Mixing: 8 Channels

For mono files, you can choose which physical connector on the PC the sound comes out on. The right-hand group of checkboxes becomes live, and you can choose to send this mono file out one or more of the connectors. Panning is only for stereo files.

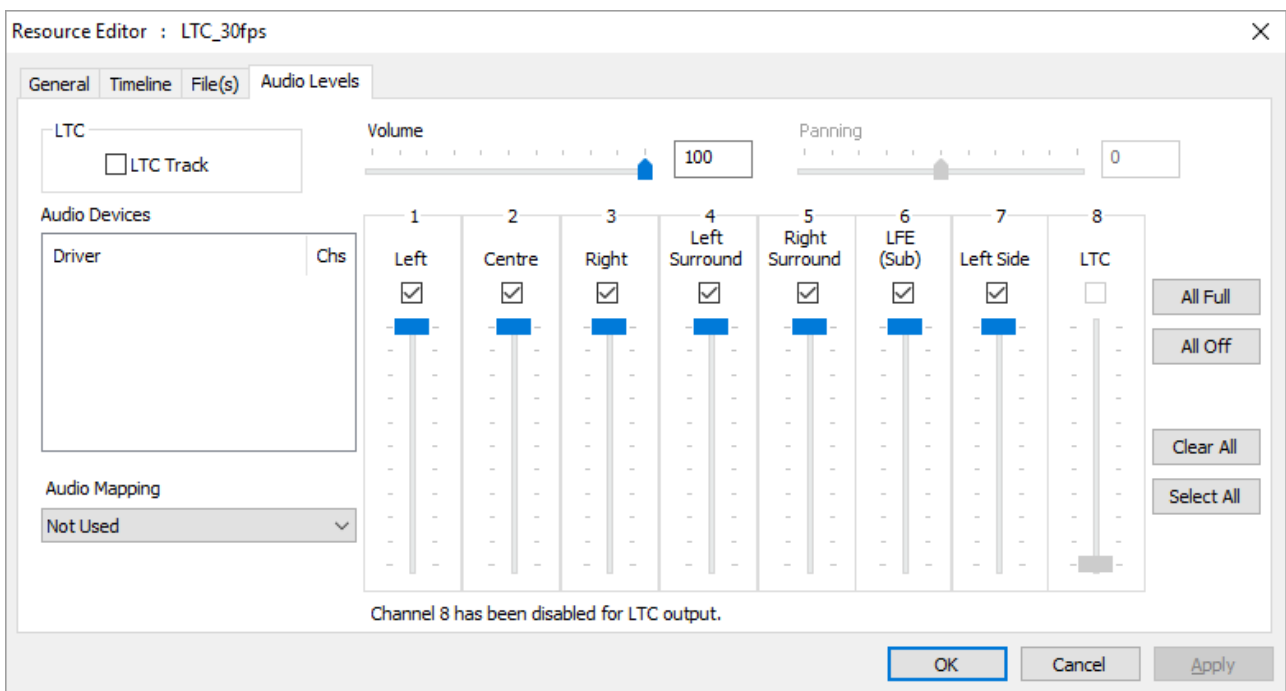

Audio levels for each speaker (mono files only) can be set using the 8 sliders on the right side, Overall volume of this track affects these individual speaker volume levels as well.

You can also choose an Audio Mapping Preset from the dropdown – see Config > Preferences > Audio Mapping to create presets.

## Audio Mixing: 32 Channels

Some sound cards have up to 32 channels, in this case, the following choices are available – note that Panning is not available on these sound cards.

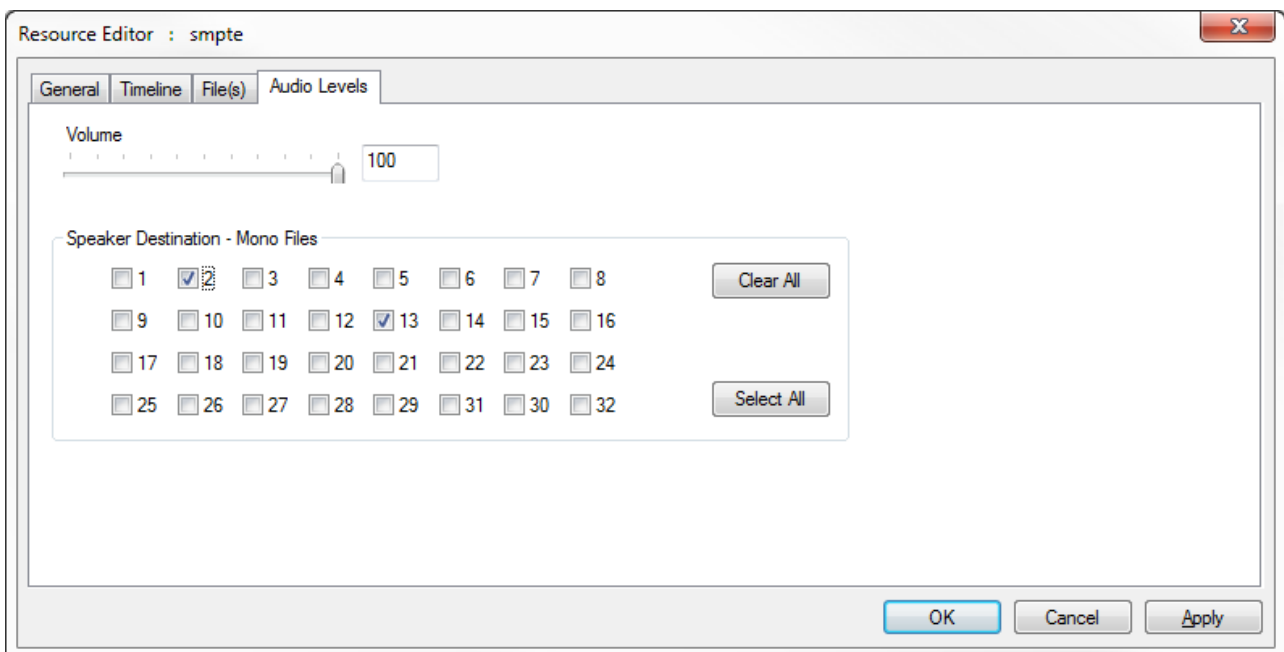

## Resource Editor: Video Capture

Video Capture is an option within Delta that can use a variety of video capture hardware including single-channel high-update rate cards, dual channel medium update cards and inexpensive web cams: any video capture device that implements a proper DirectShow filter will work with Delta.

Video Capture windows shown in the resource pool can be placed anywhere on the timeline, and shown multiple times simultaneously, allowing video-wall type effects to be created.

A Capture window can be manipulated in exactly the same way as other image-based resources, so for example, geometry, morphing geometry and transparency can be applied or changed at any time.

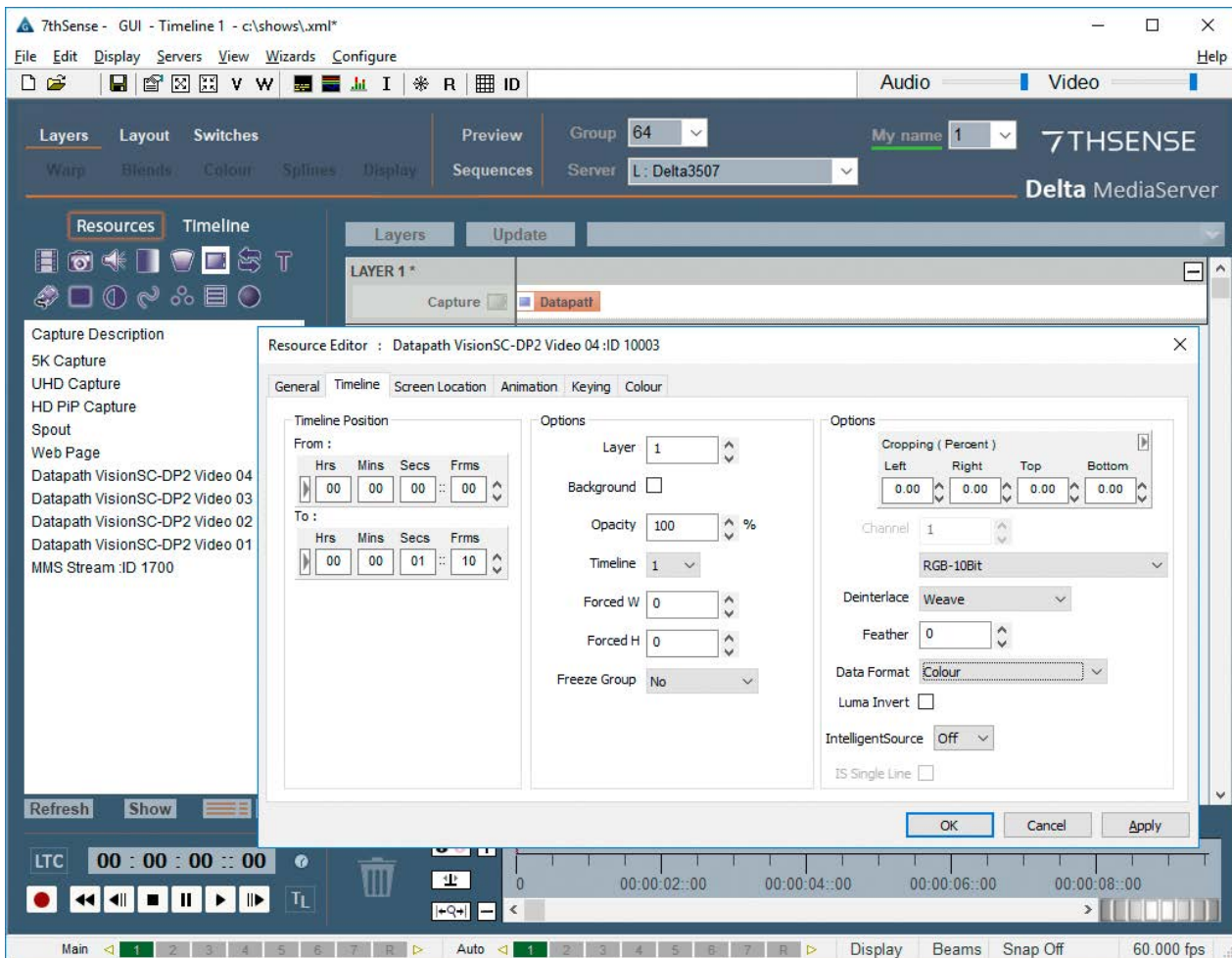

## Notes

- Video capture can be an intensive task, so if you are playing a high-resolution movie at the same time as showing a capture window, the load of the system has to be checked that it is still within the capabilities of the server.
- Some video capture cards require a separate process to create a video definition file. This file is then selected when you edit this resource.
- Direct Show compliant capture cards can be tuned using their own control applications, so to choose PAL / NTSC, deinterlacing or setup colour etc., this must be done in the manufacturer supplied application. Alternatively, use the **Video Capture Tuner** program to launch the devices setup pages.
- Most video capture devices will choose a best fit format to match the incoming video. Some do not, so you can select the video format from the resource's drop down list when editing.
 

**Note:** (from Delta 2.7 build 12) for vertically inverted capture images from a Datapath capture card, select video format 'RGB-8Bit-Flip'.
- MMS Video capture will show content from a Microsoft Media Stream. Add this device to the timeline, then configure the IP Address of the source.

The capture device can be set to always play at full update, even when the timeline is paused. Configure this in the *Configure > Preferences > Timing* page.

## Video Capture Freeze Group

Capture devices can be assigned to a Freeze Group. For each capture device type, edit the resource properties, and choose Yes or No to the Freeze Group item. When the Freeze Video Capture button in the toolbar is pressed, only those devices that are set to be part of the freeze group are frozen.

This allows certain video capture inputs to be frozen while content is changed in the background, before un-freezing.

Note that all instances of a particular video capture device freeze at the same time.

## Video Capture Device IDs

Some capture devices such as USB webcams can dynamically change the Identifier number assigned by Windows. In this case, fix the capture device Identifiers in the *Server Dialog > Preferences > Video Capture*.

## Deinterlace

For certain capture cards (such as Datapath), you can enable deinterlacing for interlaced inputs, the options are Off, Weave, Bob, Field0, Field1.

## IntelligentSource™

IntelligentSource data can be embedded in the feed to add this feature. When enabled, Teletext data in the stream can be used as an event trigger for a sequence. See [IntelligentSource™<sup>326</sup>](#).

Check 'IS Single Line' to continue monitoring the stream but not render the feed into Delta's output. This enables the user to hide and show the feed depending on the IntelligentSource data coming through. This can all be handled via Delta's system sequence which gives the user callbacks when the IntelligentSource data changes.

## Resource Editor: Spout capture

---

**Spout** is an industry open standard video sharing framework – a way of sharing whole frame buffer imagery between applications. Delta can capture Spout as a capture device and show it anywhere on the output canvas, and manipulate it as with any other capture resource type.

Spout can be used to input live realtime graphics from another application (e.g. Unreal, or Unity) resident on the server (or via network), with the realtime app running in the background behind the server's playback window. The realtime app can also render part normal imagery and part alpha plane in order to key the Spout window into the normal playback content.

Care should be taken to ensure that normal playback performance is still maintained when the realtime app is running so that smooth playback is achieved in all cases – this will be dependent on the system performance (graphics card mostly) and the realtime app's requirements.

## Configuring Spout

Install Spout on the server. Configure Spout to have a known sender name. In this example, the Spout Sender DEMO app is being used. The application can normally be found in C:\Program Files (x86)\Spout2\DEMO. If you run SpoutSender.exe you'll something similar to this:

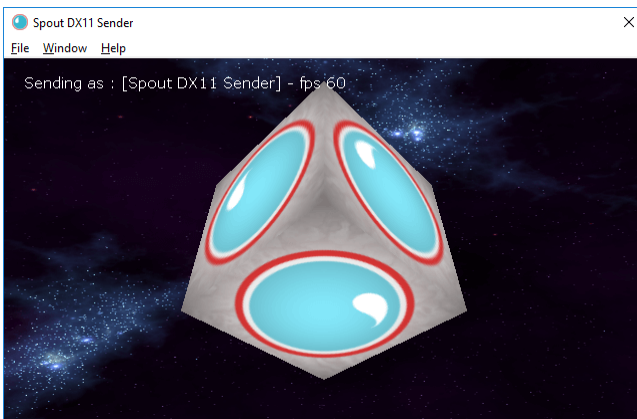

The sender name can be set by going to *File > Sender Name*. Enter the name you want to use; here we use 'test1' as an example sender name:

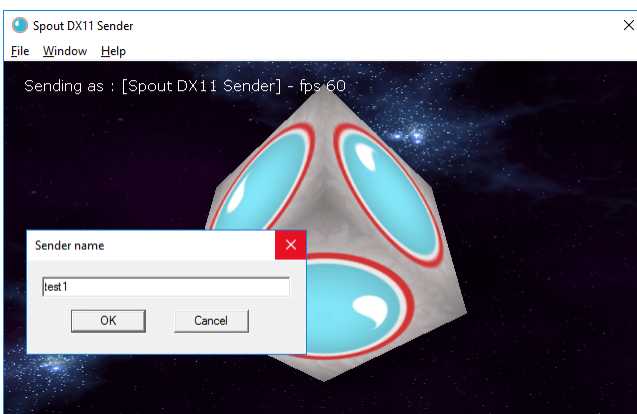

This name now shows in the sending window:



### Adding to the Delta Timeline

Open DeltaServer and DeltaGUI. From the Capture tab of the Resources window, drag the Spout resource onto the timeline. Double-click the timeline resource, and select the Timeline tab, to add the sender name you set above (test1) as the SpoutID:

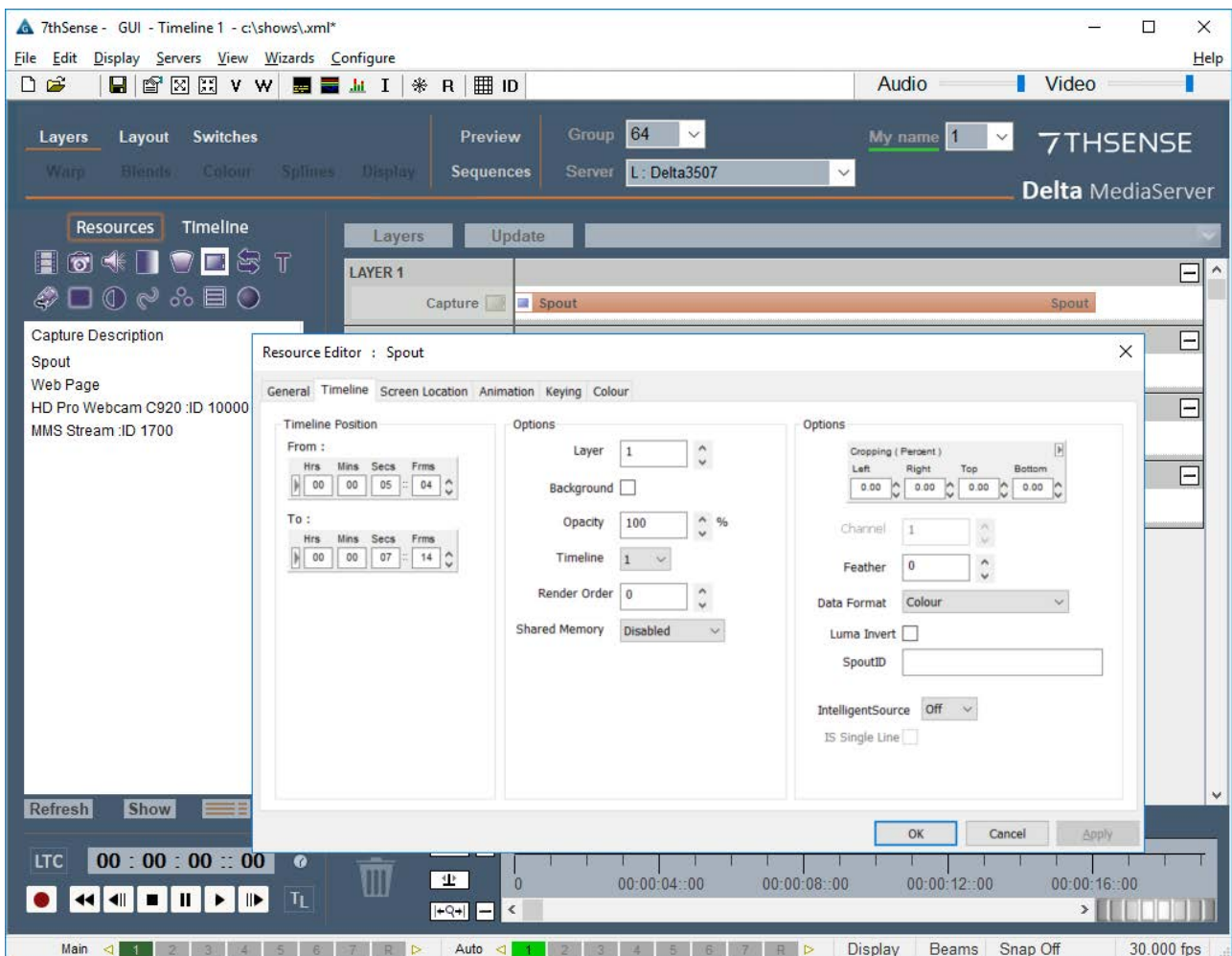

Shared Memory mode is not recommended because it is quite slow. If you are using Shared Memory mode, you will want to enable that mode in the resource. If you're using texture memory, then it should be left disabled.

Once you click Apply, the capture resource will receive the video from your specified Spout instance, and the Delta playback window will match the Spout output:

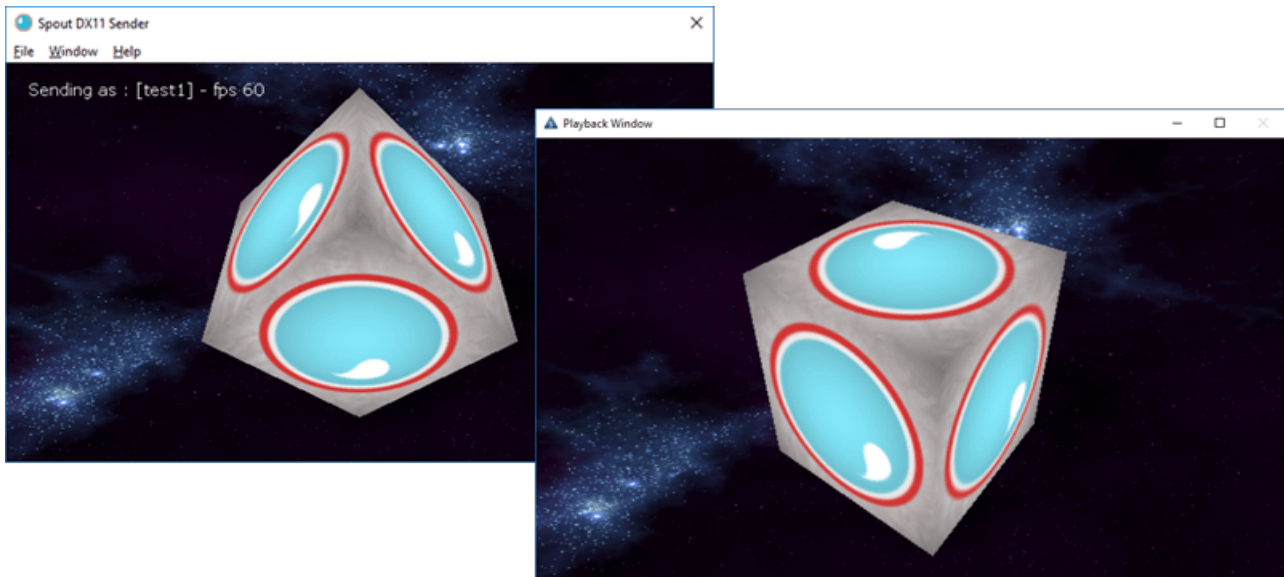

## IntelligentSource

IntelligentSource data can be embedded in the feed to add this feature. When enabled, Teletext data in the stream can be used as an event trigger for a sequence. See [IntelligentSource™<sup>326</sup>](#).

Check 'IS Single Line' to continue monitoring the stream but not render the feed into Delta's output. This enables the user to hide and show the feed depending on the IntelligentSource data coming through. This can all be handled via Delta's system sequence which gives the user callbacks when the IntelligentSource data changes.

## Resource Editor: Web Resource

---

This is a special capture resource which is a built-in web control, where you can set the URL (<http://www.mydomain.com>) to be rendered in the web control and you can also set the rendering size of the web page using the H Resolution and V Resolution parameters.

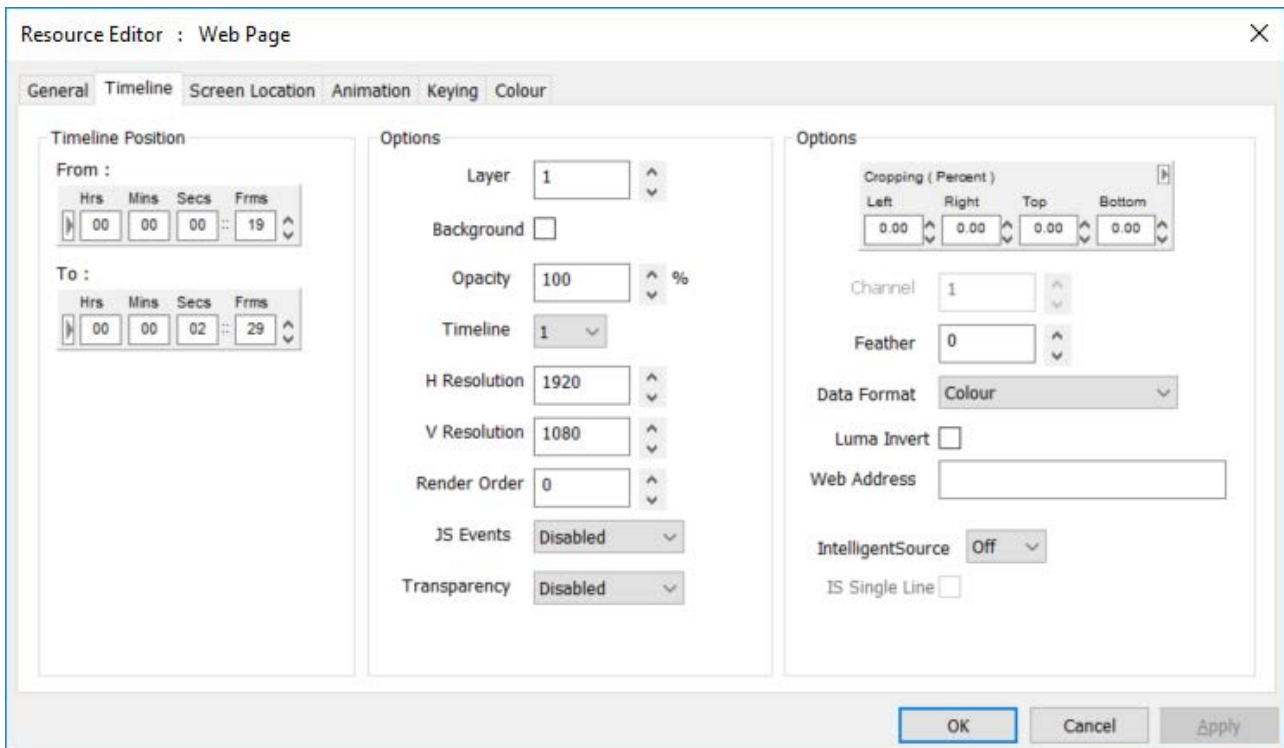

Web controls behave like all other visual media in that you can scale, position, chromakey, crop, feather etc.

You can also set the web URL from a sequence or external control using the `WEBSETURL res="External Control Name" url="http://mynewdomain.com"` or make the web control navigate using the `WEBNAVIGATE res="\ExternalControlName\" navigate=[back/forward/reload/stop]` command.

The Web Resource is based on the Chromium renderer. It does *not* support WebGL, MP4 or audio playback. However, it does support OGG/WEBM video formats in accordance with [https://developer.mozilla.org/en-US/docs/Web/HTML/Supported\\_media\\_formats](https://developer.mozilla.org/en-US/docs/Web/HTML/Supported_media_formats).

## JavaScript Events

When using Web Page resources on the timeline, it's possible to trigger JavaScript events within the web page from Delta. These are enabled in the Resource Editor (below, called **JS Events**).



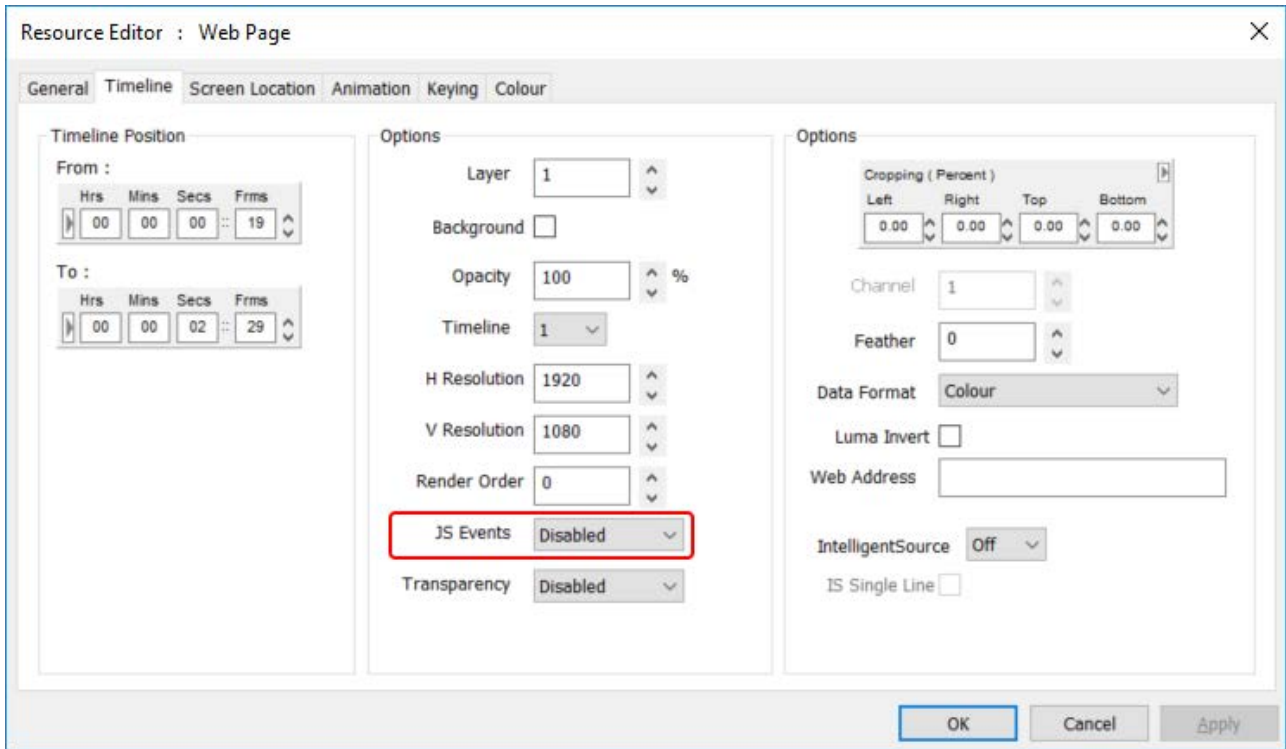

JavaScript applications must register a callback to `window.onDeltaServerReady` which, when called, indicates that the global object `DeltaServer` has been created and is ready to use. Callbacks can be registered on the `DeltaServer` object by calling `DeltaServer.on("[event]", callback)`.

It is important that this function is created at the global level, outside of any typical loading callbacks/lambda's such as `window.onready` or `jQuery $(function() {});`.

### On 'frame' event arguments

Name	Type	Description
relativeFrame	Integer	Frame number relative to the start of the Web View resource, that is the number of frames into the current resource.
absoluteFrame	Integer	Frame number of the timeline of this Web View resource.
progress	Float	From 0 to 1, indicates the progress through the resource. Useful for synchronising animation and events across multiple Web Views or Delta servers.

'enterscope', and 'leavescope' are called when the current Web Page resource enters/leaves scope.

### Sample Code

```

window.onDeltaServerReady = function () {
    DeltaServer.on('frame', function (relativeFrame, timelineFrame,
progress) {

```

```
    // called on each frame
    document.getElementById("frameNum").innerHTML = relativeFrame;
    document.getElementById("timelineNum").innerHTML = timelineFrame;
    document.getElementById("percent").innerHTML =
Math.round(100*progress);
  });
  DeltaServer.on('enterscope', function () {
    // called on resource entering scope
  });
  DeltaServer.on('leavescope', function () {
    // called on resource leaving scope
  });
}
```

## Development and Debugging

A mock DeltaServer JS library is provided for testing events from a regular web browser. The library can be downloaded with the following link and included in the webpage like a normal JS library.

[Right-click this link](#) to download: *mock-deltaserver.js*.

## Transparency

For web resources created with transparency, this can be enabled here. Transparency will add 33 per cent colour load on this resource.

## IntelligentSource™

IntelligentSource data can be embedded in the feed to add this feature. When enabled, Teletext data in the stream can be used as an event trigger for a sequence. See [IntelligentSource™<sup>326</sup>](#).

Check 'IS Single Line' to continue monitoring the stream but not render the feed into Delta's output. This enables the user to hide and show the feed depending on the IntelligentSource data coming through. This can all be handled via Delta's system sequence which gives the user callbacks when the IntelligentSource data changes.

## Resource Editor: NDI Capture

---

From Delta 2.6.50 the NDI® (Network Device Interface) resource has been available in the capture resource pool.

**Note:** This receives unencrypted NDI streams, but does not currently support audio, and is capped at 30 fps.

## NDI ports

NDI goes out of all NICs and uses port 5353 (the mDNS Bonjour port) to detect NDI sources. For any NICs where you do **not** want NDI traffic to go, the quickest solution is to create a firewall rule to block port 5353.

## Network

As part of the NDI tools available online from NewTek there is a tool called NDI® Access Manager. This tool allows you to specify whether your machine uses Unicast or Multicast for sending (below, right). Multicast can be used when appropriate switches are available in the network to control where the NDI traffic is routed to. Its worth knowing this is available for Delta NDI Preview, but also for anyone sending feeds to capture in Delta.

- For more about the NewTek NDI® Access Manager, Groups and Networks, please see the overview video at <https://www.ndi.tv/tools/>.

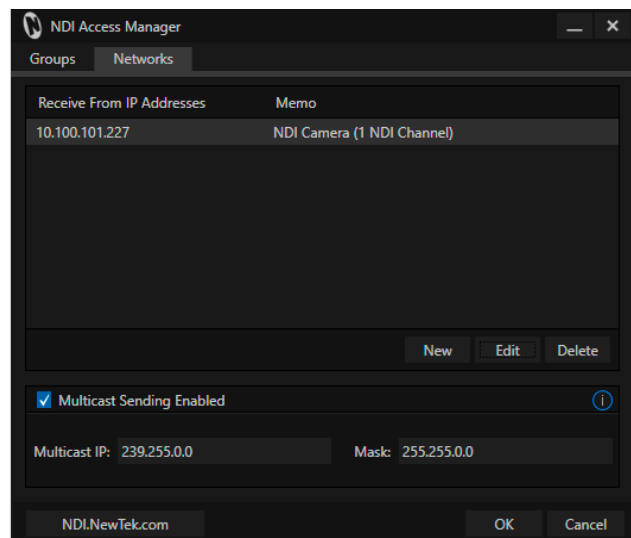
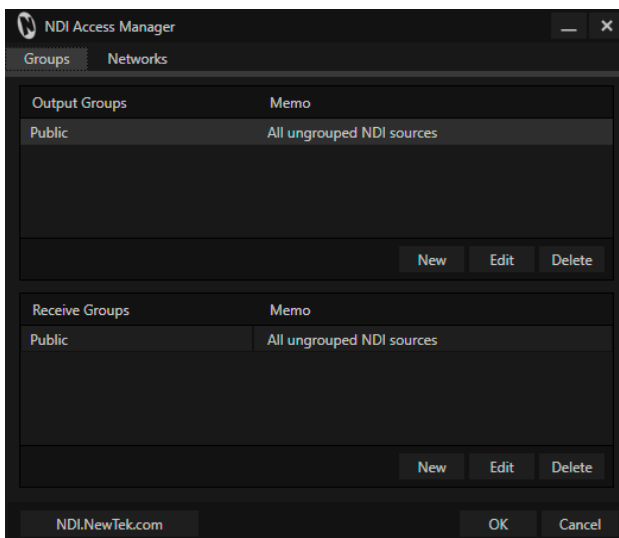

## Ports

The channel count matters – you must ensure that, starting from port 5960 and counting up, enough network ports are available for the maximum supplied by any one NDI source – plus one (for NDI server messaging). So, adding an IP Address for a system supplying one NDI channel to the Receive from IP list means ports 5960 and 5961 must be available. A second source serving eight NDI channels would need ports 5960 – 5968 to be free, etc. (source: [NewTek](#)).

Delta NDI Capture resources are managed the same as other capture resources, and require the stream name in the *Resource Editor > Timeline : Address*:

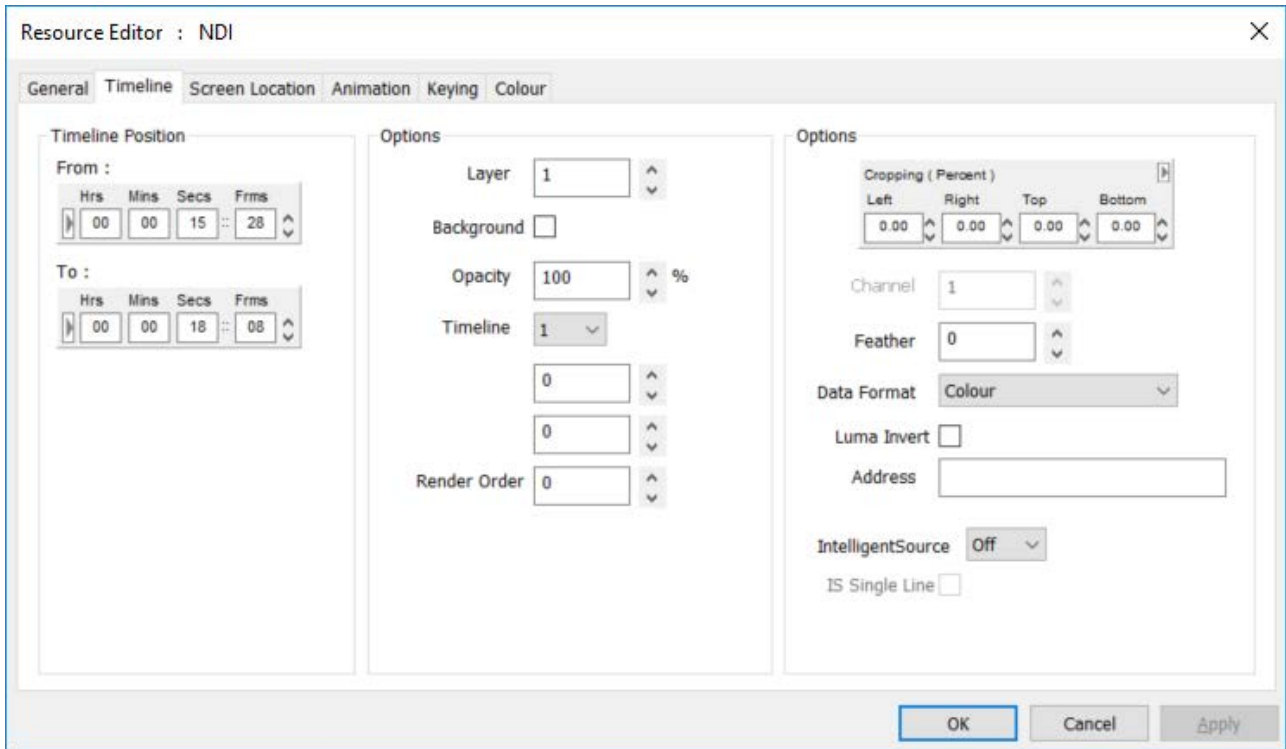

This is not the IP address, but the name of the source device and stream, syntax as shown. In this example, using NewTek Studio Monitor and NewTek NDI® Test Patterns, the source address can be read in the title bar:



## IntelligentSource™

IntelligentSource data can be embedded in the feed to add this feature. When enabled, data added to frain the stream can be used as an event trigger for a sequence. See [IntelligentSource™<sup>\(326\)</sup>](#).

Check 'IS Single Line' to continue monitoring the stream but not render the feed into Delta's output. This enables the user to hide and show the feed depending on the IntelligentSource data coming through. This can all be handled via Delta's system sequence which gives the user callbacks when the IntelligentSource data changes.

## Resource Editor: Stream Capture

Stream capture resources can receive unencrypted network-address video streams, including HLS, HTTP, HTTPS, Pro-MPEG FEC, RTMP, RTMPE, RTMPS, RTMPT, RTMPTE, RTMPTS, RTP, SCTP, TCP, TLS, UDP.

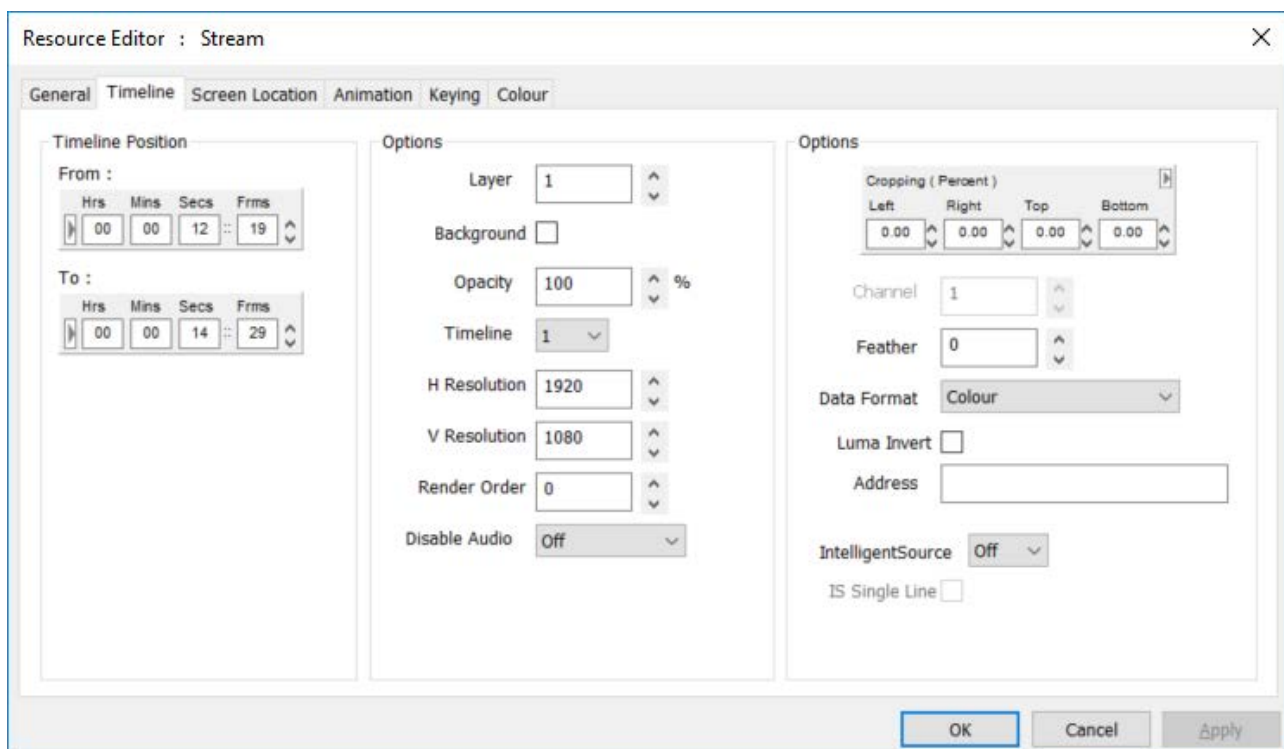

Broadcast capture can be received, for example by using Zixi software to handle the encryption licence, and/or record the stream for subsequent replay or looping). This will re-stream to Delta as a UDP stream using an address in the format: `udp://127.0.0.1:####` (localhost and configured port), or replay a recorded .ts (Transport Stream) movie file as a Stream resource with the address being the full movie file path and name.

A guide to using Zixi Receiver software to display, record and replay broadcast sources can be found online [in our user portal](#).

## IntelligentSource™

IntelligentSource data can be embedded in the feed to add this feature. When enabled, Teletext data in the stream can be used as an event trigger for a sequence. See [IntelligentSource™<sup>326</sup>](#).

Check 'IS Single Line' to continue monitoring the stream but not render the feed into Delta's output. This enables the user to hide and show the feed depending on the IntelligentSource data coming through. This can all be handled via Delta's system sequence which gives the user callbacks when the IntelligentSource data changes.

## IntelligentSource™

---

When video capture resources are included in a Delta show of any kind, you may want to ensure that frozen or broken input is detected and replacement media to be substituted, or even send a message to alert the condition.

Delta (from version 2.7) can be enabled to add (*Display > Output Setup*) and read IntelligentSource data inserted into the top line of capture source frames, showing Delta that frames are updating. If the incrementing data stops, a System sequence will be triggered in Delta and this can be used to perform a required action.

In the resource editor (timeline tab) for all capture resources, there is a checkbox to enable IntelligentSource listening. This will trigger the default IntelligentSource System sequence. You can find this in *Sequences > System*:

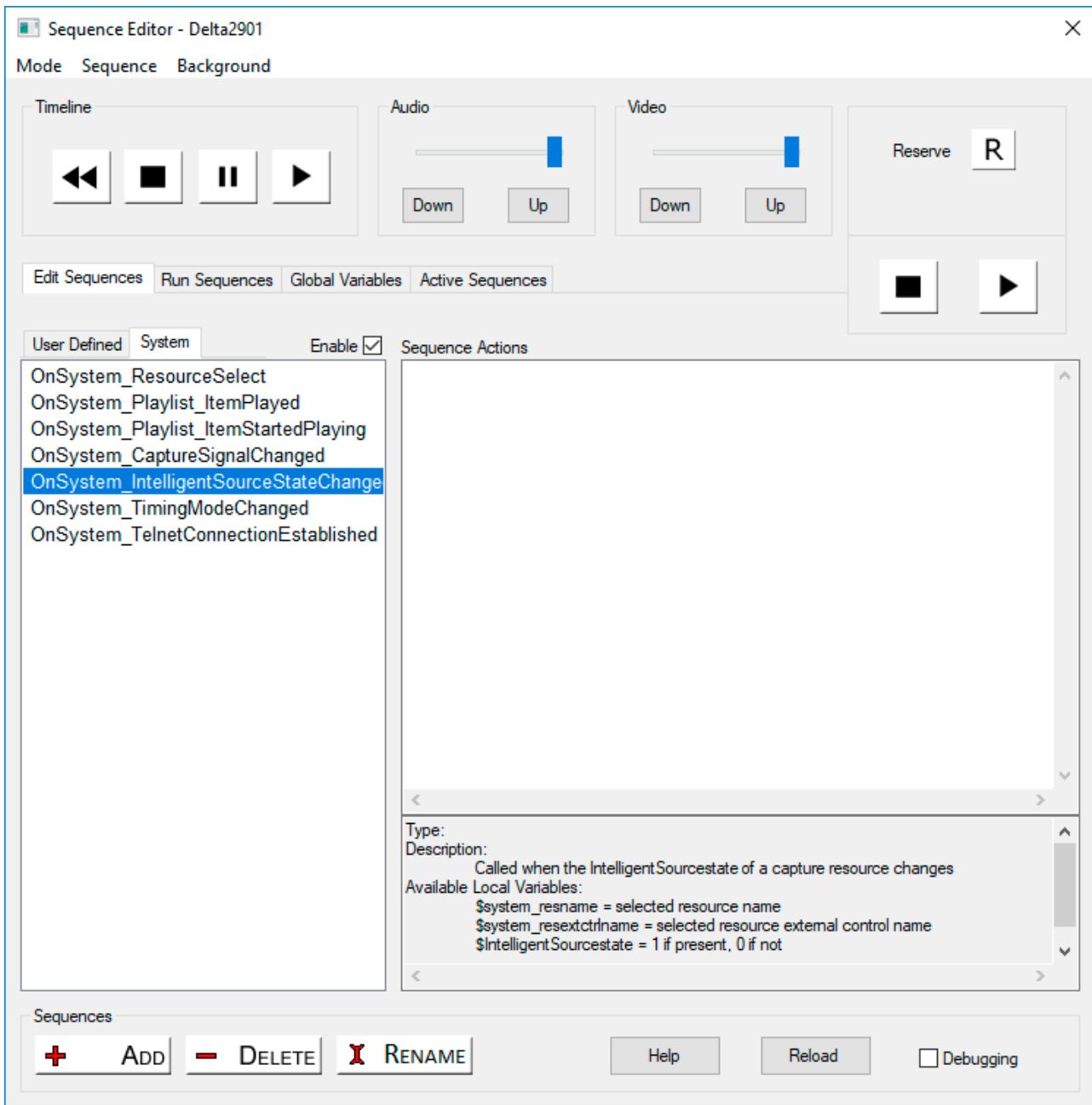

Add whatever sequence steps you require as a response.

An API is available from 7thSense to enable content developers to add IntelligentSource data. Ask also for guide reference [M450 IntelligentSource API User Guide](#).

IntelligentSource is also a feature for failover in [Juggler systems](#).

## Video Capture Groups

**Legacy: video capture groups only applies to older systems.** This was superseded when Datapath introduced 'input ganging' within their driver, which is better for being simpler. Datapath input ganging achieves the same goal, and is supported by Delta.

Multiple video captures can be grouped and treated as a single timeline resource. The main use case for this is for domes, to enable a 4K × 4K fisheye image to be assembled from two 4K × 2K inputs in a 1 × 2 arrangement:

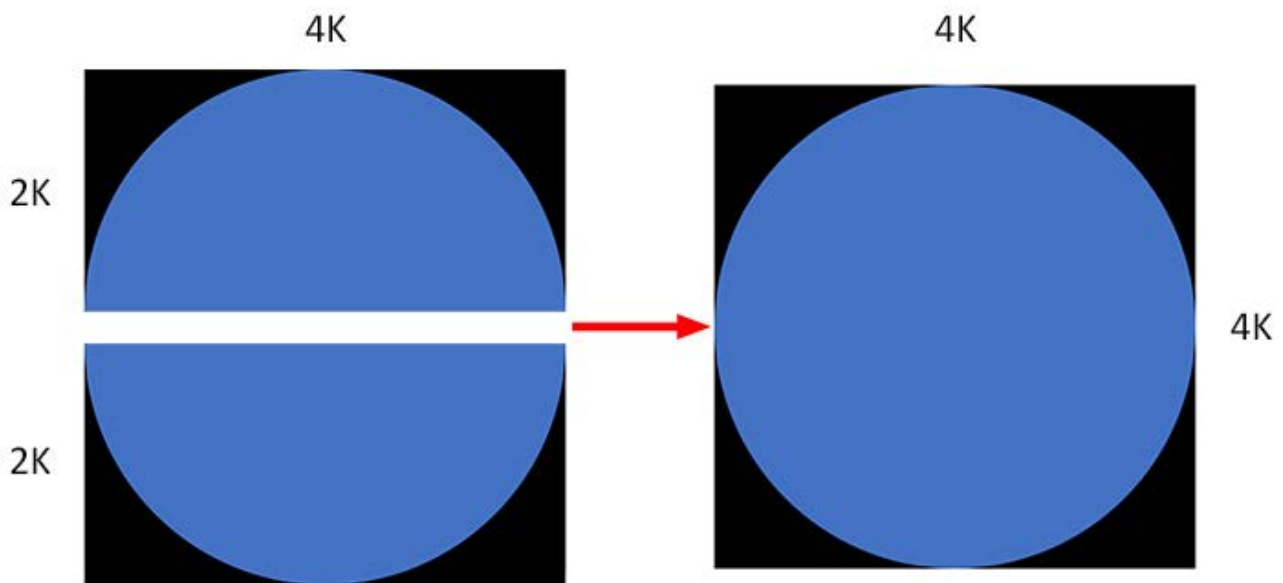

Copy this example .xml code for a capture group and amend it as required. It must be saved to C:\Program Files\7thSense\Delta\System\VidCapGroups.xml:

```
<?xml version="1.0" encoding="ISO-8859-1"?>
<VIDCAP_GROUPS>
  <Count>3</Count>
  <GROUP1>
    <Name>Workstation4K</Name>
    <NumDevices>2</NumDevices>
    <GridSizeX>1</GridSizeX>
    <GridSizeY>2</GridSizeY>
    <DEVICEID1>4</DEVICEID1>
    <DEVICEID2>5</DEVICEID2>
    <CaptureWidth>4096</CaptureWidth>
    <CaptureHeight>2048</CaptureHeight>
    <CaptureFormat>422</CaptureFormat>
  </GROUP1>
  <GROUP2>
    <Name>Uniview4K</Name>
    <NumDevices>2</NumDevices>
```



```

<GridSizeX>1</GridSizeX>
<GridSizeY>2</GridSizeY>
<DEVICEID1>2</DEVICEID1>
<DEVICEID2>3</DEVICEID2>
<CaptureWidth>4096</CaptureWidth>
<CaptureHeight>2048</CaptureHeight>
<CaptureFormat>422</CaptureFormat>
</GROUP2>
<GROUP3>
<Name>Uniview3K</Name>
<NumDevices>2</NumDevices>
<GridSizeX>1</GridSizeX>
<GridSizeY>2</GridSizeY>
<DEVICEID1>2</DEVICEID1>
<DEVICEID2>3</DEVICEID2>
<CaptureWidth>3200</CaptureWidth>
<CaptureHeight>1600</CaptureHeight>
<CaptureFormat>422</CaptureFormat>
</GROUP3>
</VIDCAP_GROUPS>

```

The xml tags are fairly self-explanatory:

**<VIDCAP\_GROUPS>**

Identifies the xml file type.

**<Count>n**

The number of groups being used.

**<GROUPn>**

Identifies the group

**<Name>**

Names the group for video capture (see Resource Editor below). This Name only appears in DeltaGUI as a Capture Resource.

**<NumDevices>**

Number of devices addressed in this group.

**<DEVICEIDn>**

Identifies the device by its DirectX ID.

**<GridSizeX>, <GridSizeY>**

Matrix dimensions of all devices in this group.

**<CaptureWidth>, <CaptureHeight>, <CaptureFormat>**

Capture dimensions of each device in this group. Format can be 422 or 420.

## Identify the Capture Devices (visible to DeltaServer)

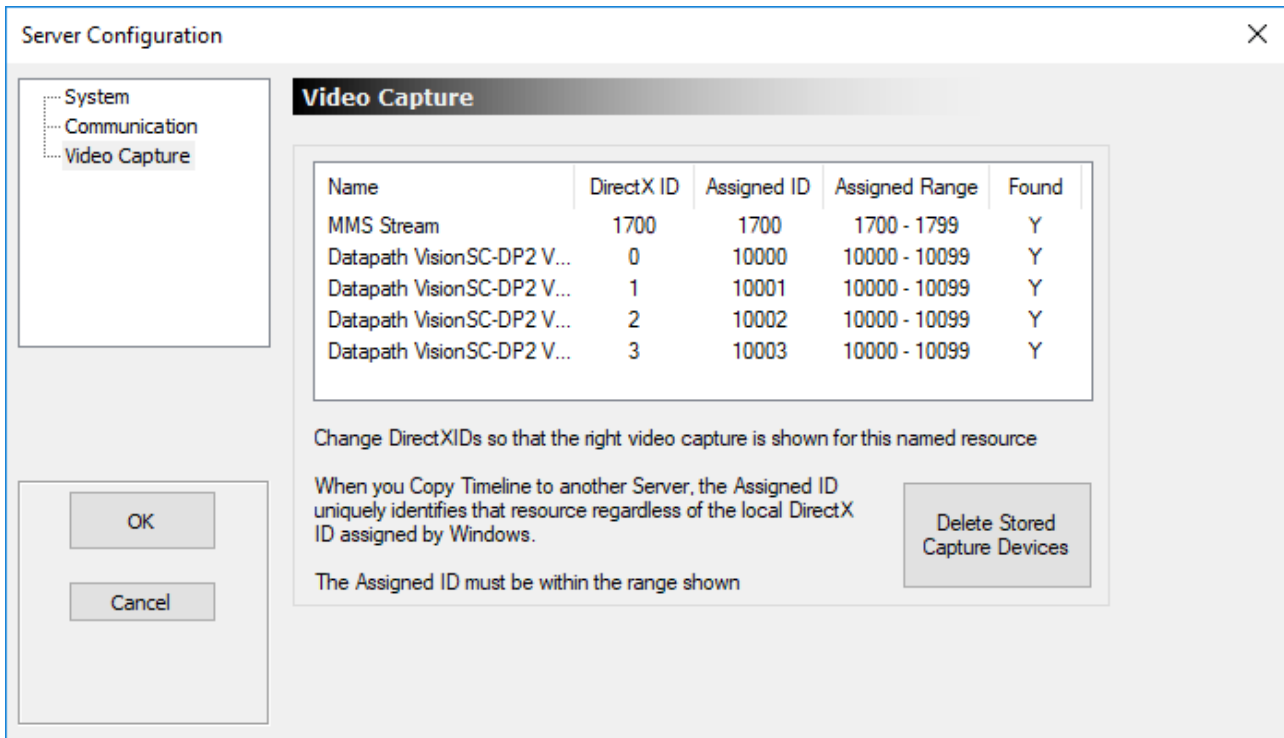

Check here for device details to use in the xml.

## Using Capture Resources in DeltaGUI

Find your video capture (or Capture Group) resource in the DeltaGUI Resources panel and apply it to the timeline:

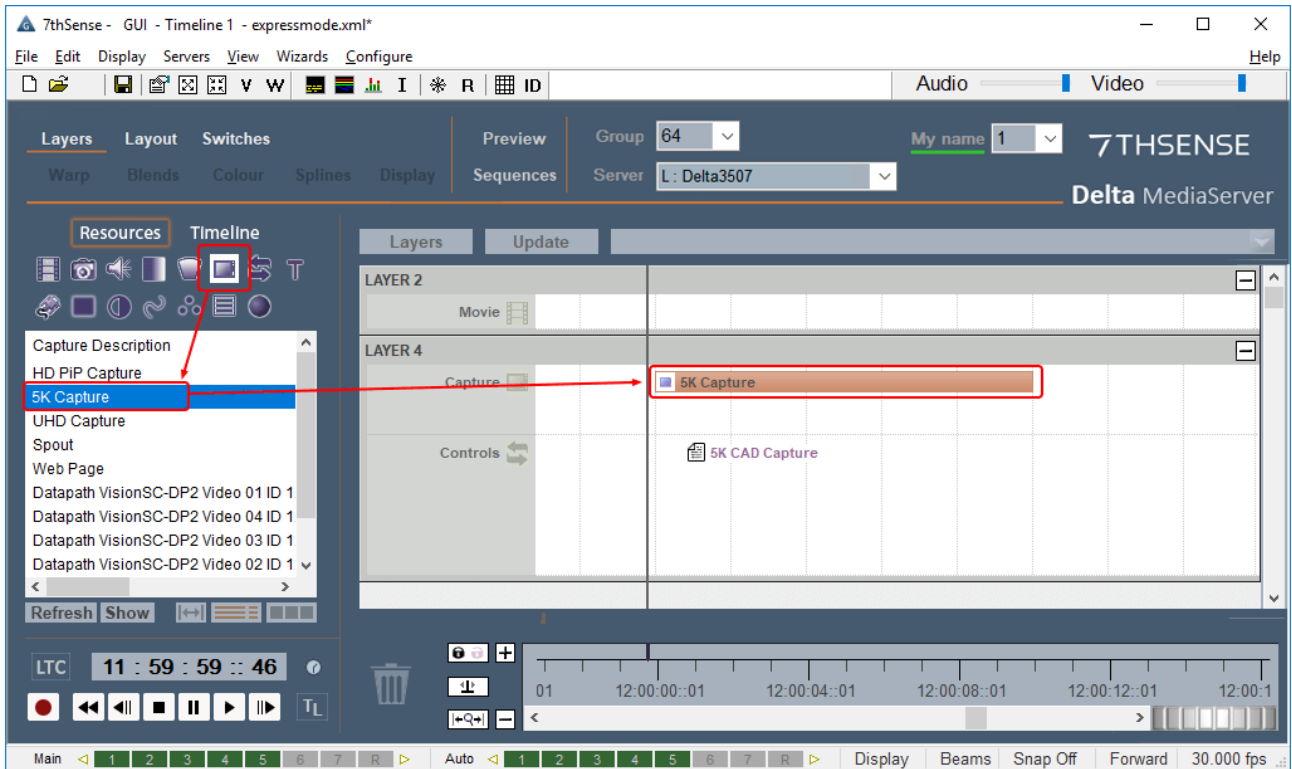

### Preferences > Miscellaneous (DeltaGUI)

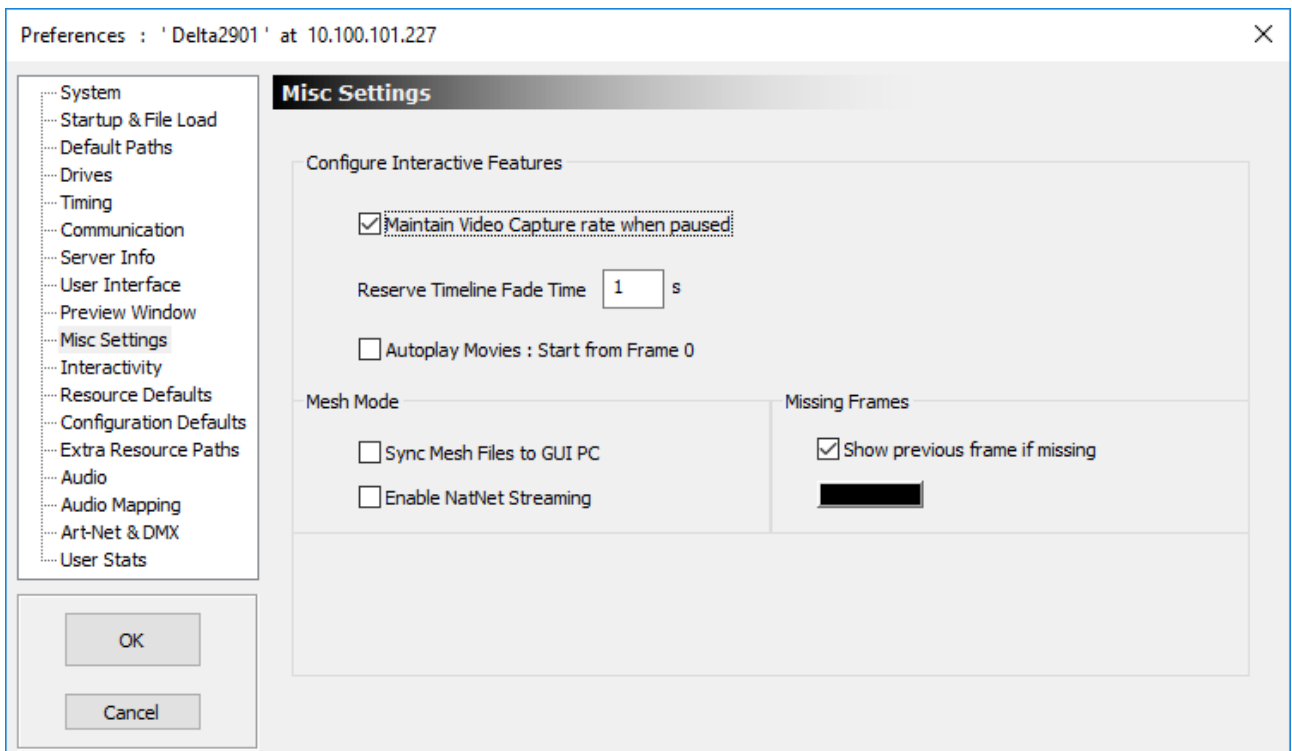

Ticked by default, 'Maintain Video Capture rate when paused' will maintain frame capturing when a show is stopped or paused.

## Resource Editor: Controls Placeholder

Controls Placeholders occupy space in a layer on a timeline. You can name them and describe them in readiness for replacement by required media, but nothing is displayed on the playback window.

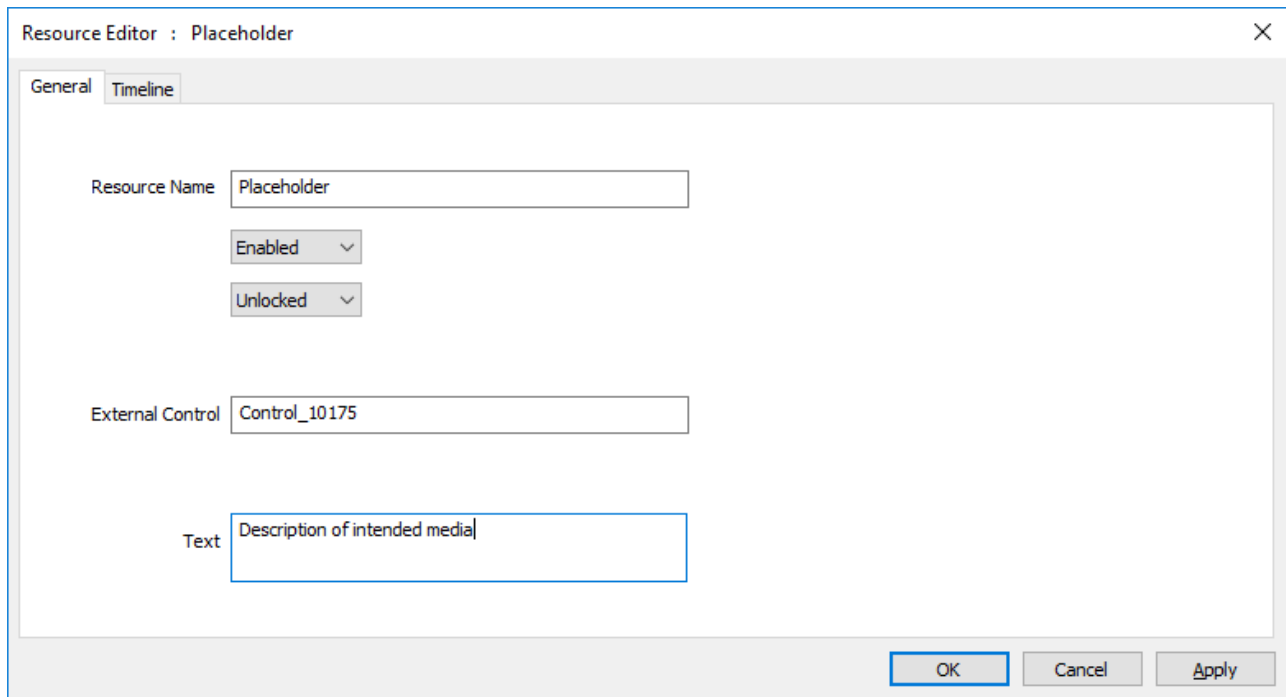

This placeholder is not the same as an image or movie placeholder from the Movie or Images Resource panel.

➤ [Media Placeholders](#) <sup>(281)</sup>

## Resource Editor: GoTo Control



From the Controls Resources, GoTo is a timeline control that is dragged onto the timeline and configured. GoTo is also available as an External Control.

The screenshot shows the 'Resource Editor : Goto' dialog box with the 'General' tab selected. The 'Timeline' sub-tab is also visible. The 'Resource Name' field contains 'Goto'. Below it are 'Enabled' and 'Unlocked' dropdown menus, both set to their default state. The 'External Control' field contains 'Control\_10477'. The 'Comment' field is empty. At the bottom right, there are 'OK', 'Cancel', and 'Apply' buttons.

GoTo is used to jump to a timeline position (frame or marker) and perform an action:

The screenshot shows the 'Resource Editor : Goto' dialog box with the 'Timeline' sub-tab selected. The 'Timeline Position' section has 'At:' followed by a time selection grid with values: Hrs: 00, Mins: 00, Secs: 02, Frms: 16. The 'Options' section includes: 'Go to' time selection grid (Hrs: 00, Mins: 00, Secs: 00, Frms: 00), 'Timeline' dropdown set to '1', 'Target' field with '0', 'Current' field with '4', 'Mode' dropdown set to 'Stop', 'On Trigger' dropdown set to 'Play Through', and 'Go to Type' dropdown set to 'Time'. At the bottom right, there are 'OK', 'Cancel', and 'Apply' buttons.

### GoTo

Select a frame time or marker name. (For Marker, set Go to Type first.)

**Target**

Enter the number of concurrent times the GoTo will activate, after which it will be ignored and hit counts are reset. The timeline marker will show counts/target in red until the target is reached and it goes green.

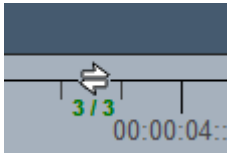
**Current**

This is just a counter of how many hits. It resets when the show is restarted. A number entered here will be incremented but resets to zero.

**Mode**

Play or Stop when the playhead goes to the target position.

**On Trigger**

Play through or stop when the playhead hits the control.

**Go to Type**

Select Time or Marker. This feature was added in Delta 2.7.

## Resource Editor: Text

---

**Text (normal)**

The text resource allows you to place simple titling **onto the show**. You can adjust the font used, size and colour of the text, as well as previously mentioned items such as animation, screen location, opacity etc.

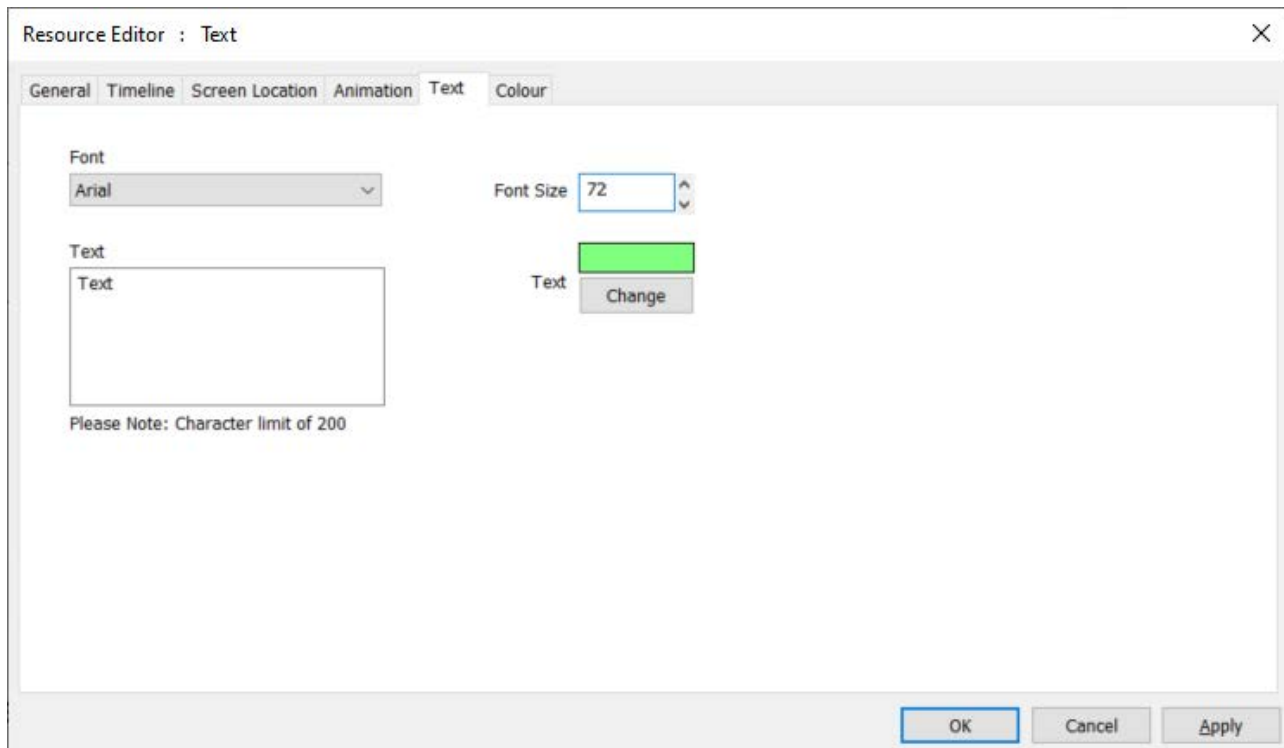

## Special Text Resources

### Timecode

This text resource shows the frame or timecode of the **timeline** (select which, from the display option). Count options are relative to the timeline, or position of the text resource. In the **Text** tab, format the Font face, size and colour. In the **Screen Location** tab, position the text on the screen.

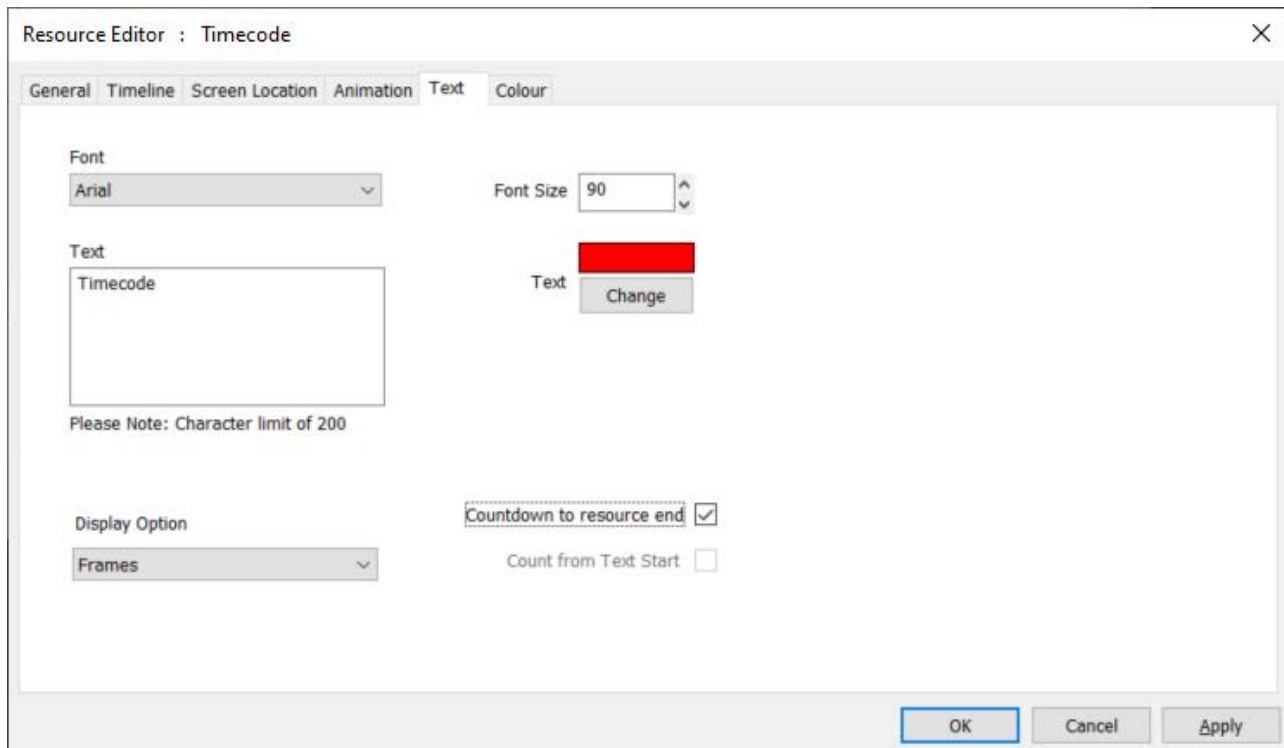

### Countdown to resource end

Show number of frames (or time) remaining of text (does not apply to Disk Frames display option).

### Count from Text Start

Show number of frames (or time) of text played, from the start of text resource.

### Display Option

**Frames:** for any movie format, the current frame number

**TC:** the Timecode for the current frame

### Movie Timecode

By default, the movie timecode relates to a movie in the same layer as this text resource. This can only be unambiguous for very simple timelines. It is better always to use the External Control name for the required movie resource. The displayed text shows information for the current frame of the referenced movie (name, number or time):



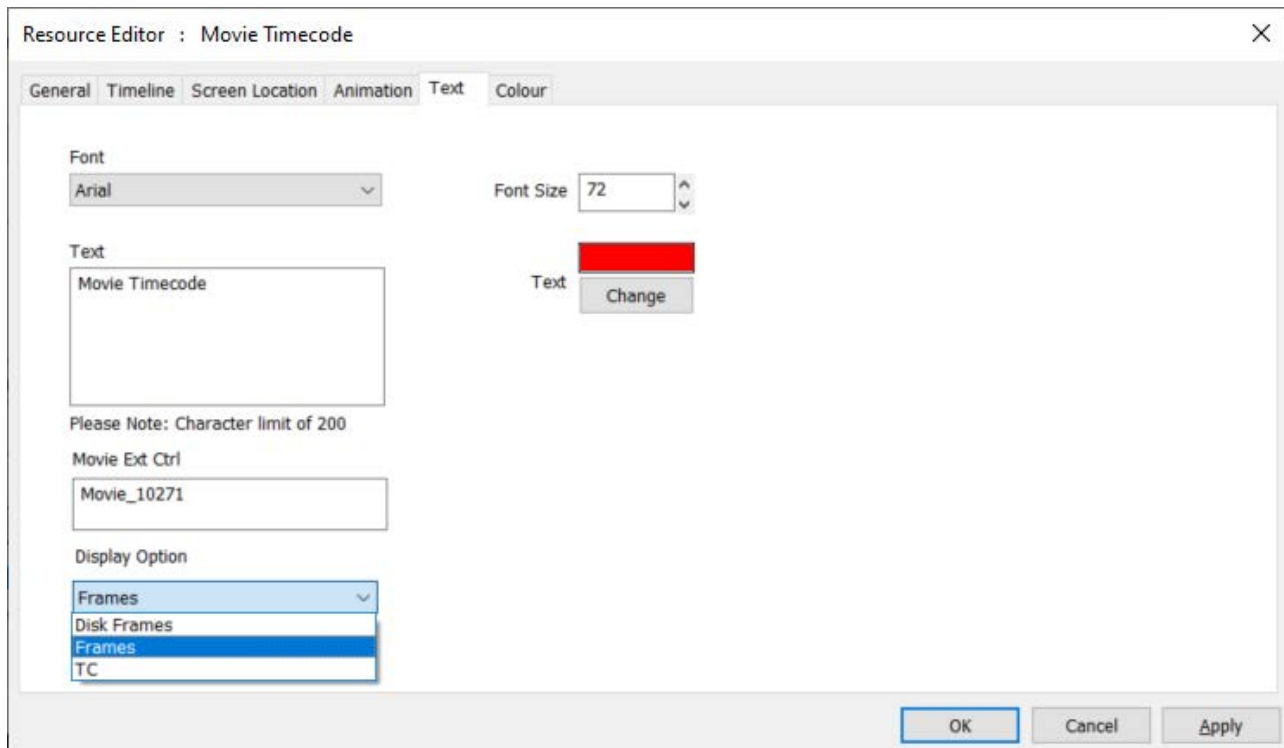

### Movie Ext Ctrl Name

Copy the External Control Name from the Required Movie's *Properties* > *General* tab.

### Display Option

**Disk Frames:** used for 7th or tga movies, displays the movie location and current frame title

**Frames:** for any movie format, the current frame number

**TC:** the Timecode for the current frame

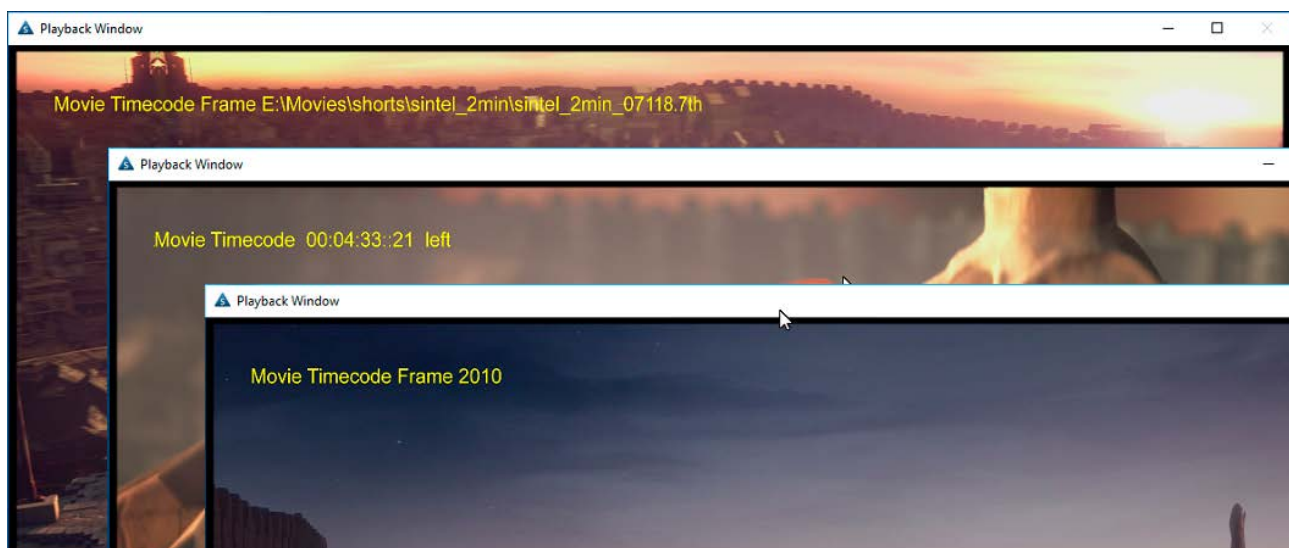

## Resource Editor: Keying (Chroma and Luma)

Chroma and Luma keying is available on visual resources (Images, Video Capture and Movies) and is typically used for masking out areas or green screen applications.

### Chroma Key

This is available for, and sets which colour will become transparent to layers below, and is most usable on multi-coloured media (not monochrome), since you pick a colour and tolerance / range around that colour.

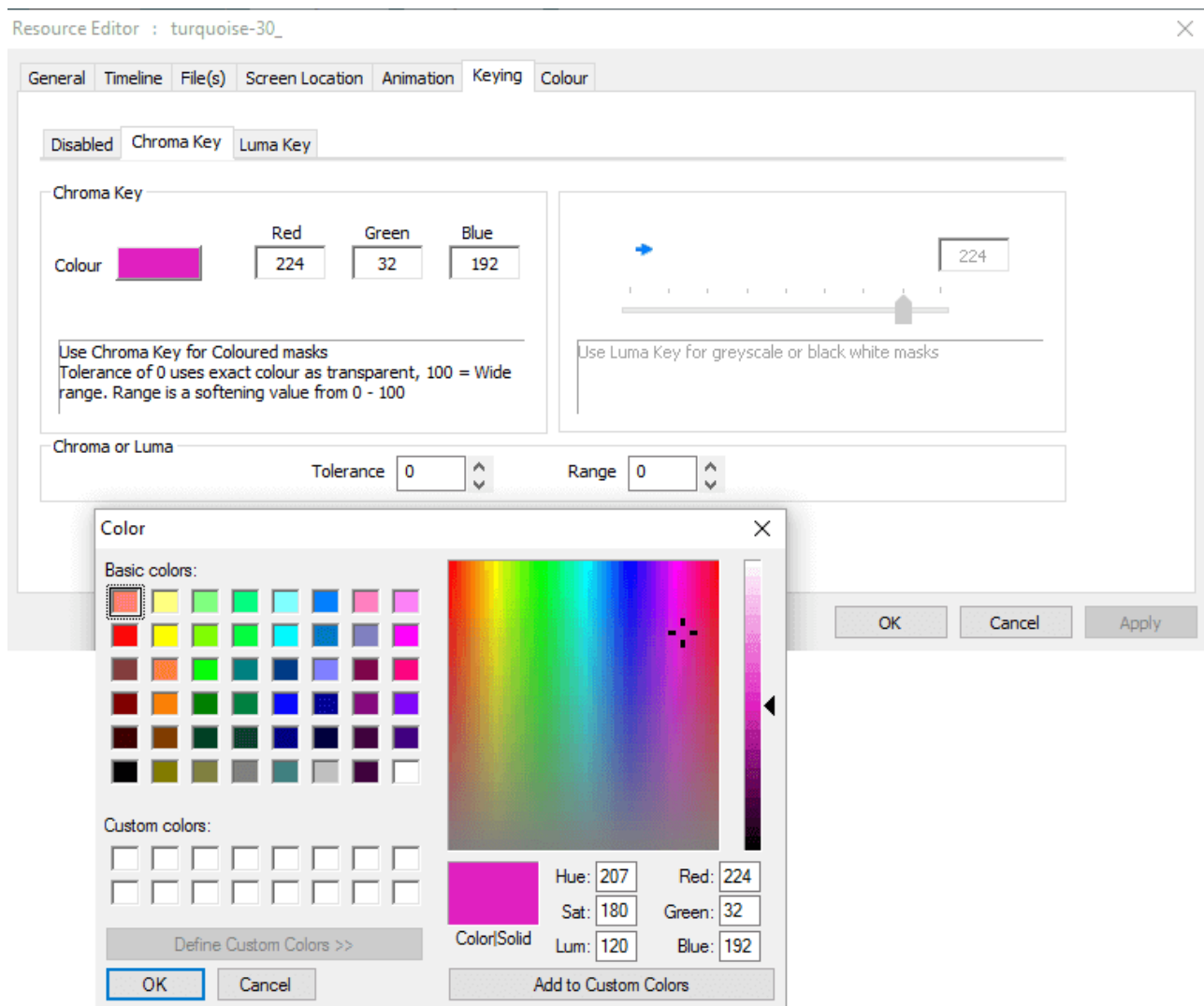

### Colour

Choose which colour will be transparent.

### Tolerance

0 means the exact colour only will be transparent, higher numbers will allow similar colours to be transparent.

**Range**

Range is a softening value about the tolerance

**Notes**

- For the Dynamic Keying resource, you can set the chroma values using the dialog above or with the SETTRANSITIONPARAMS external control command.
- Due to compression artefacts, for example in jpg images, what may look like a single colour will be surrounded by similar colours which interfere with this process. Increasing the tolerance can help this problem. It is common when using chroma key images to design specific colours for keying, and selecting an uncompressed format such as TIFF or TGA.
- Uncompressed images such as bmp preserve exact colour perfectly.

**Luma Key**

This is available for, and sets which monochrome luminance value will become transparent to layers below, and is most usable on monochrome (not multi-coloured), since you pick a greyscale value and tolerance / range around that value.

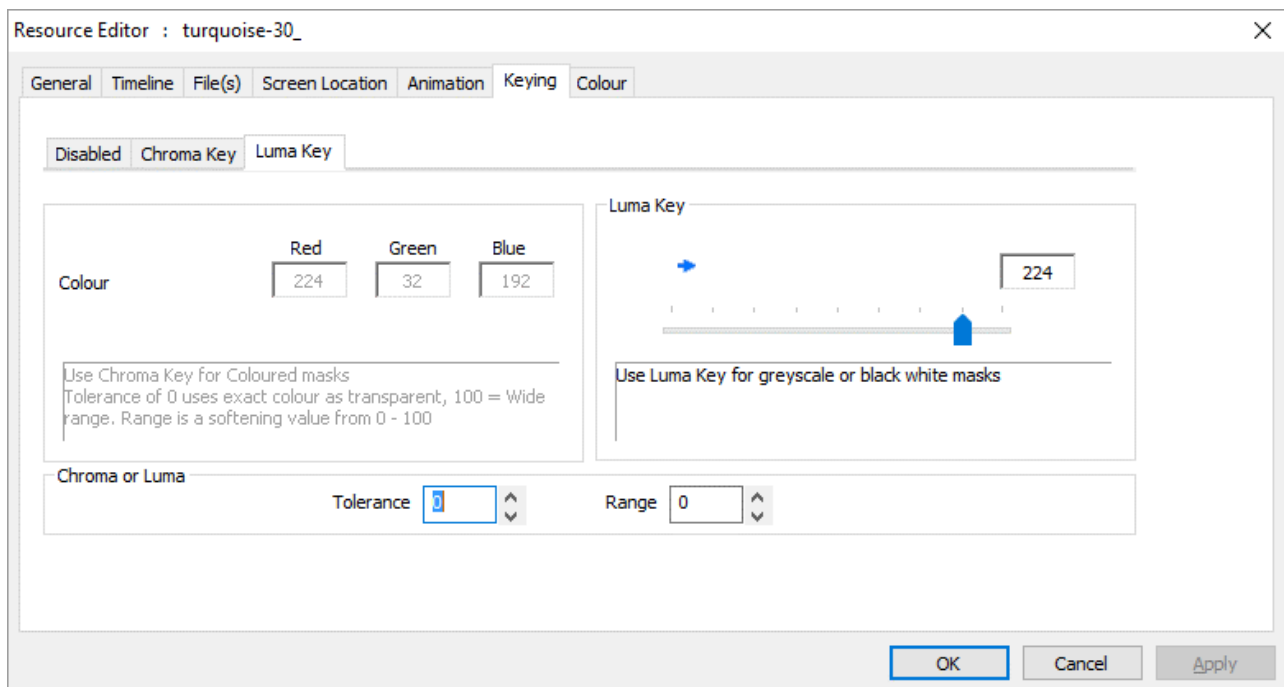
**Luma Value**

Choose the value to make transparent.

**Tolerance**

0 means the exact colour only will be transparent, higher numbers will allow similar colours to be transparent.

### Range

Range is a softening value about the tolerance

## Resource Editor: Colour Controls

All visual resources (Movies, Images, Video Capture and Text) can have the contrast, brightness and gamma set on individual resources by choosing the colour tab:

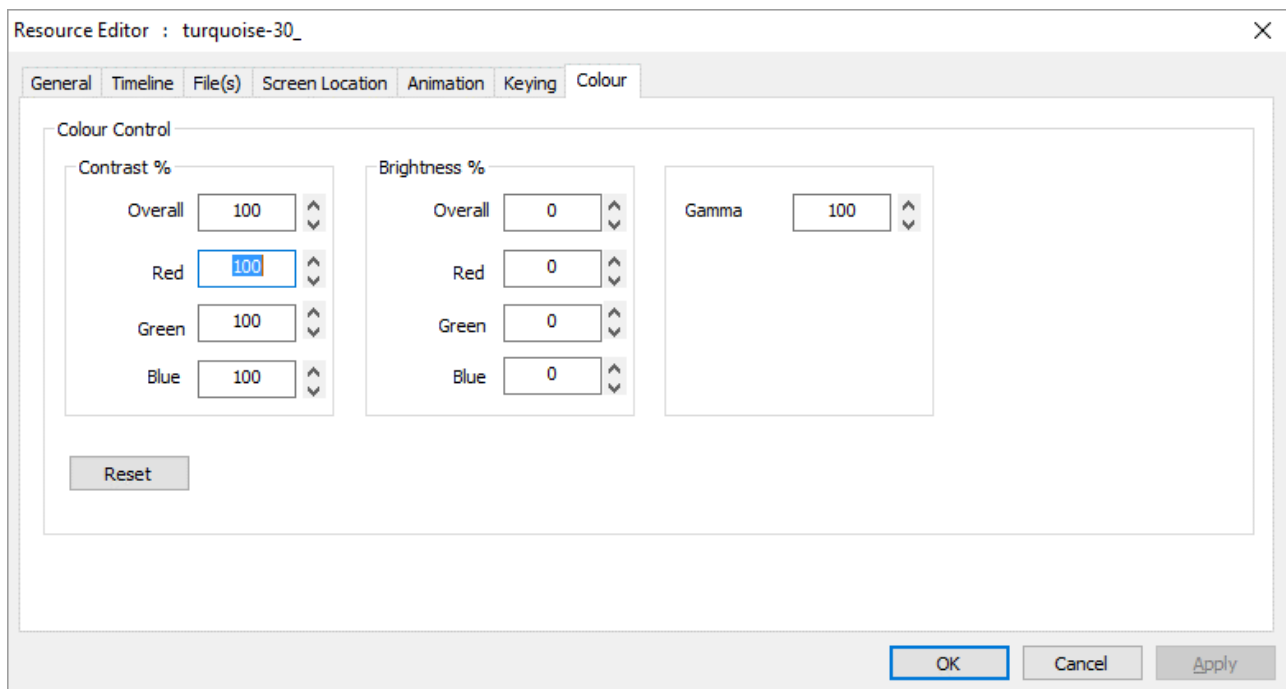

## Resource Editor: Art-Net and DMX resources

This resource can be an Input or Output, and you can edit a subset of the parameters compared to the main Art-Net and DMX editor.

➤ See also [Art-Net and DMX](#) <sup>(379)</sup>

## Output Device

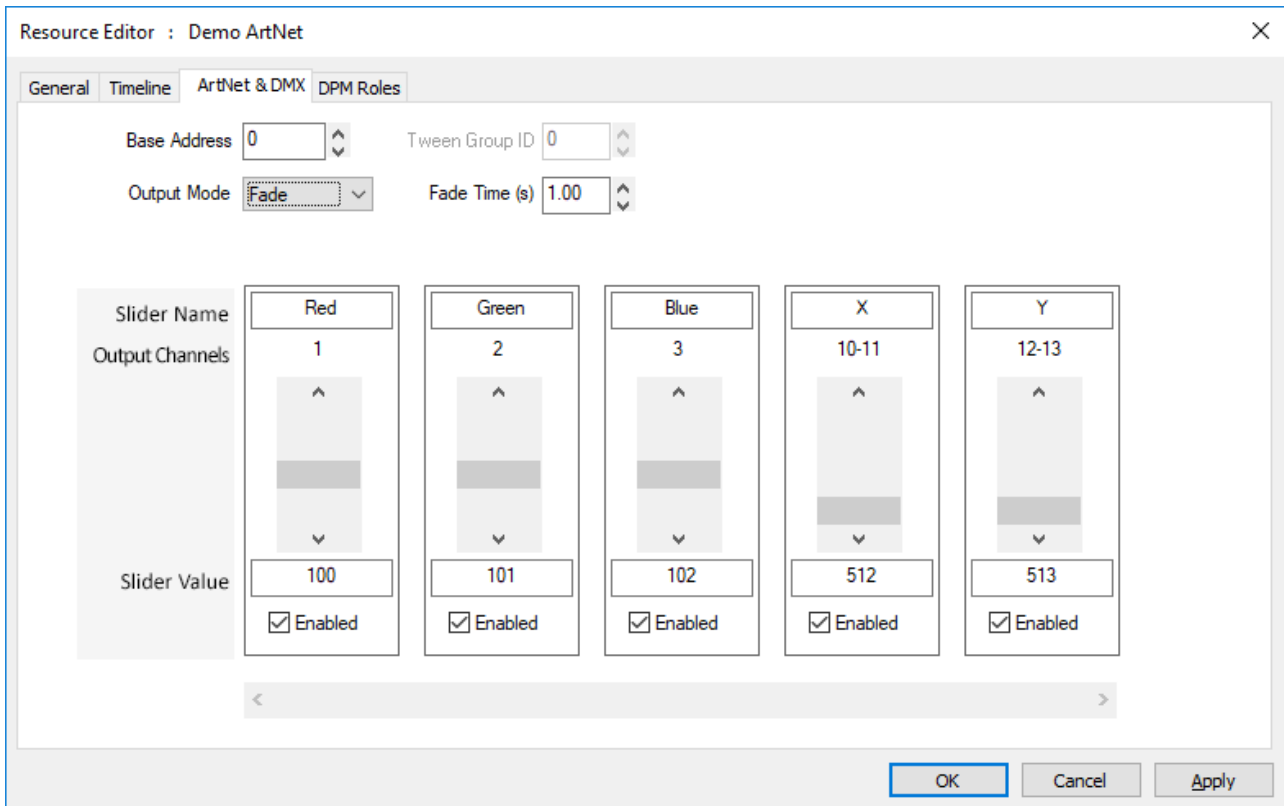

Set the channel values, base address and Mode for this one resource:

### Fade Mode

Fade to the preset values over the fade time

### Instant Mode

Instantly change to the values (within this tween group)

### Tween Mode

Tween to other Instant or Tween mode resources in this tween group

## Input Device

Set the Control Message, SubNet, Universe. The values in the named channels will replace the placeholders in the Control Message (e.g. in the example below, the 'Y' value will replace the "%Y" string with the value in Art-Net channel 12).

**Note** that setting Slider Values is only here for testing, since the incoming Art-Net data will set these values and trigger the message on any change in value.

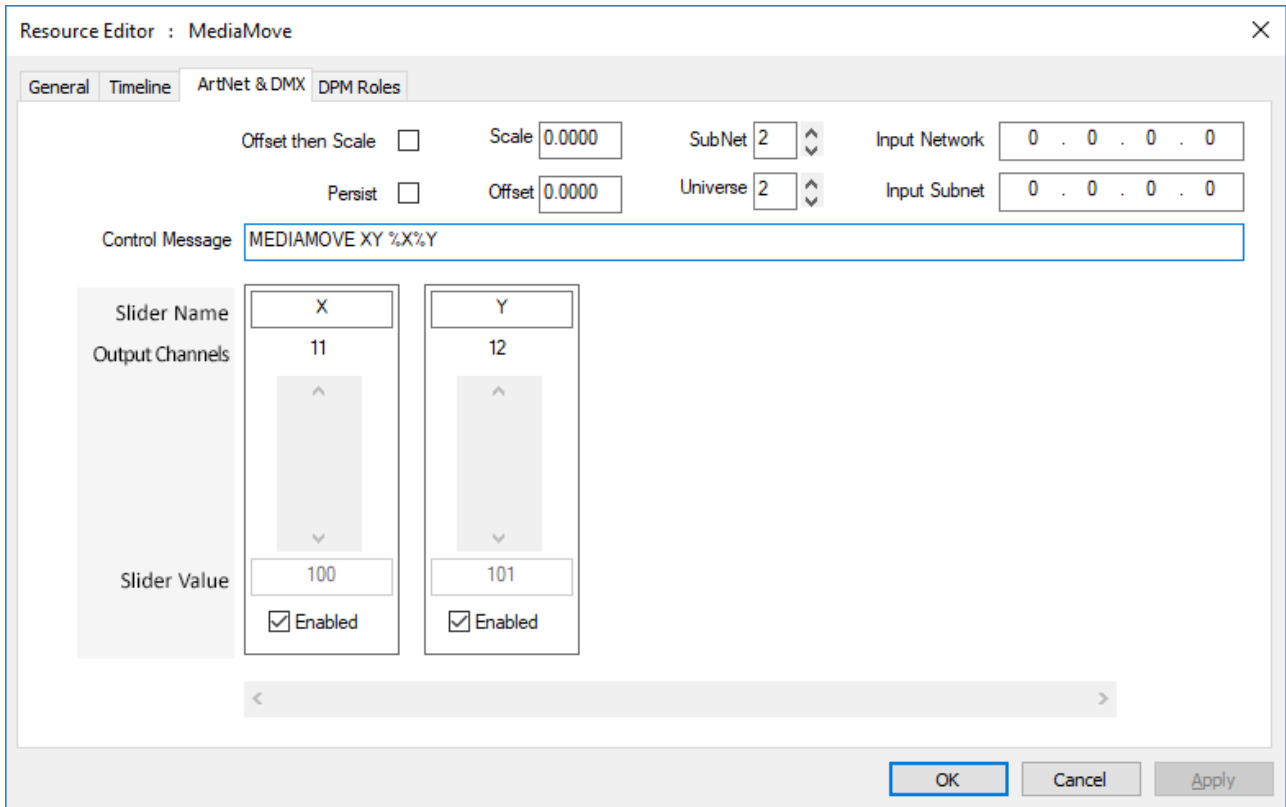

## Building a Show by Combining Resources

Timeline resources are accepted onto layers with a hierarchy of order and effect, as follows.

### Media Layers

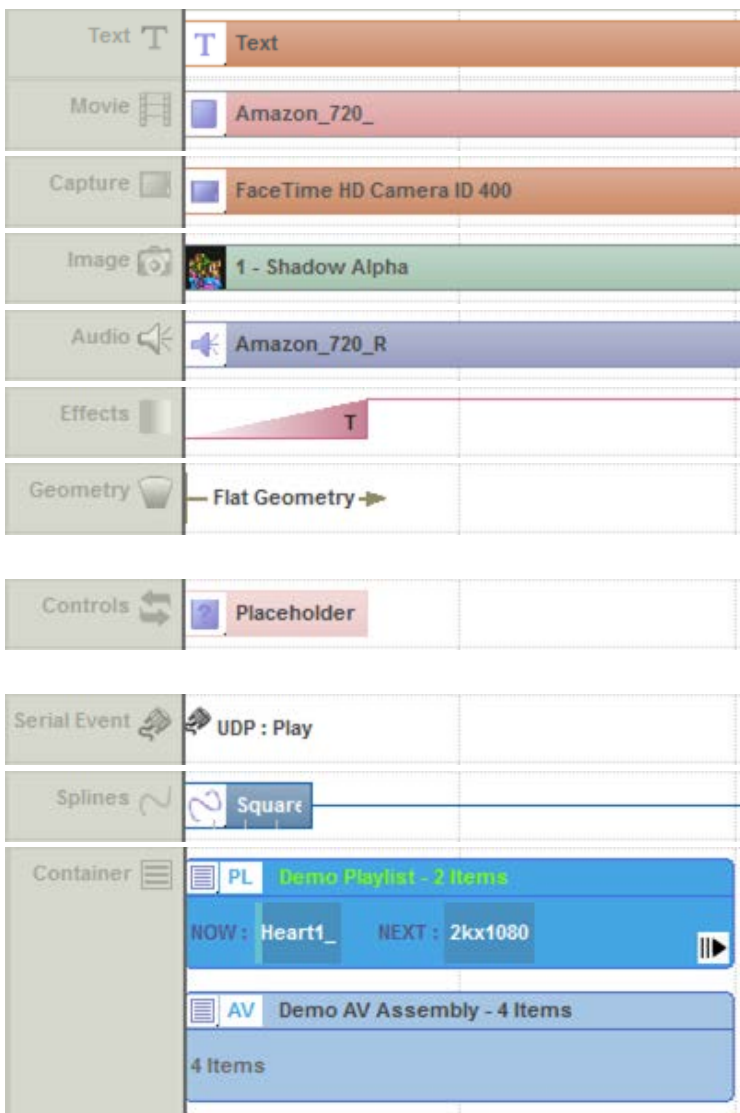

**Text:** can be used multiple times.

**Movies:** Turn on looping to drag longer than the native length

**Live Capture:** Can be any length and placed multiple times on the timeline

**Still Image:** Can be any length and placed multiple times on the timeline

**Audio:** Turn on looping to drag longer than the native length

**Transparency:** Applies to the layer, not individual media

**Geometry:** applies from the start point onwards only stops when another geometry resource hit.

**Placeholder:** Does not appear on screen, simply a placeholder to be allocated to media.

**Serial Event:** sends out any characters at this frame

**Spline:** Motion path followed by all visual media when in scope.

**Playlist:** Contains list of media which plays non-stop when the play head is in scope with it.

**AV Assembly:** Contains 1 visual + N audio resources to keep grouped.

### Art-Net and DMX Layer



**Art-Net Output:** Sets preset DMX channels to these values over time

**Art-Net Input:** Listens to preset DMX channels and triggers external control command using them

### Background and Display Layer



**Background Geometry:** Sets warp per channel



**Blends:** Enables edge blending per channel

**Colour:** Enables colour adjustment per channel

## Screen Location (in Flat Plane or Mesh mode)

This tab allows you to specify that the Image, Movie or Video Capture occupies a section of screen less than the full screen, and additionally, you can roll the image through 360 degrees.

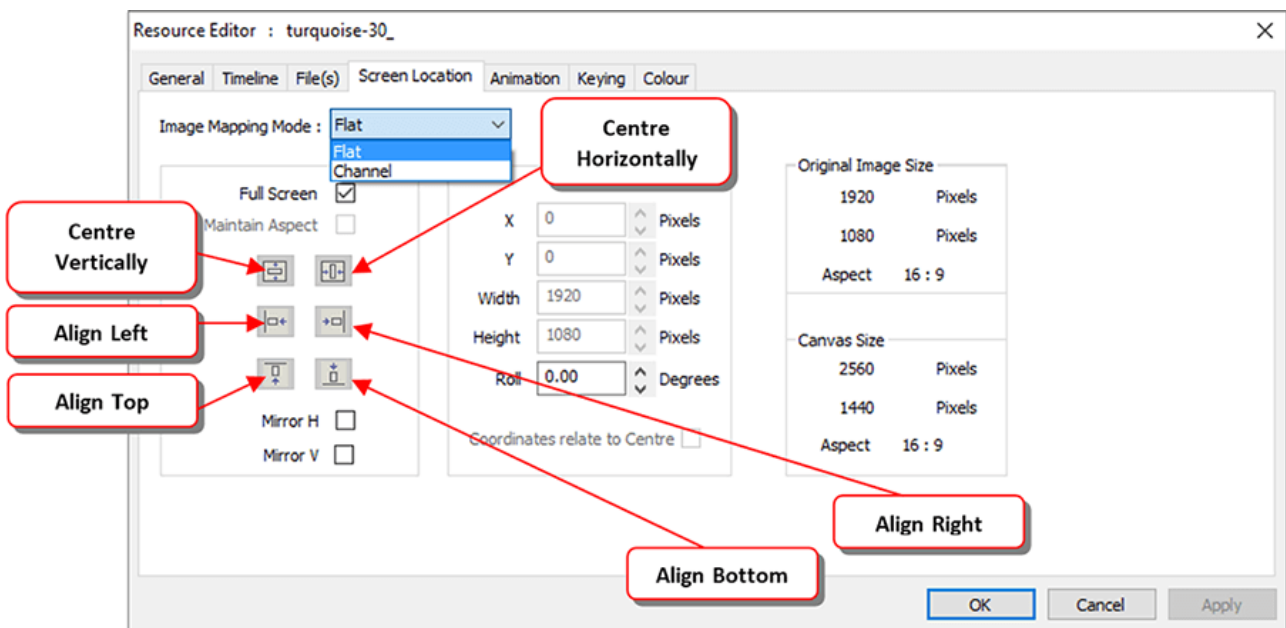

This allows you to perform scaling on the image, so you can zoom up on a part of an image and position it in the centre of the canvas.

See also 'Resource Layout' in the next section, using the Layout (rather than Layers) view, for sizing and placing media.

### Image Mapping Mode

can be Flat (coordinates relate to the whole canvas) or Channel Mapped (coordinates relate to the selected channel only). If you choose Channel Mapped and untick Fullscreen, the top left corner of the resource is the channel's top left corner, rather than the overall canvas top left corner. Channels are setup in *Config > Display*.

### Maintain Aspect

when checked, the height is auto-calculated based on the original Image Size aspect.

### Mirror H and Mirror V

can invert the visual resource at any time.



Pressing **alignment** buttons will align the image with respect to the canvas.

The **Canvas** is discussed in the *Display Configuration* section, but briefly, this is how a display could look with an image set to:

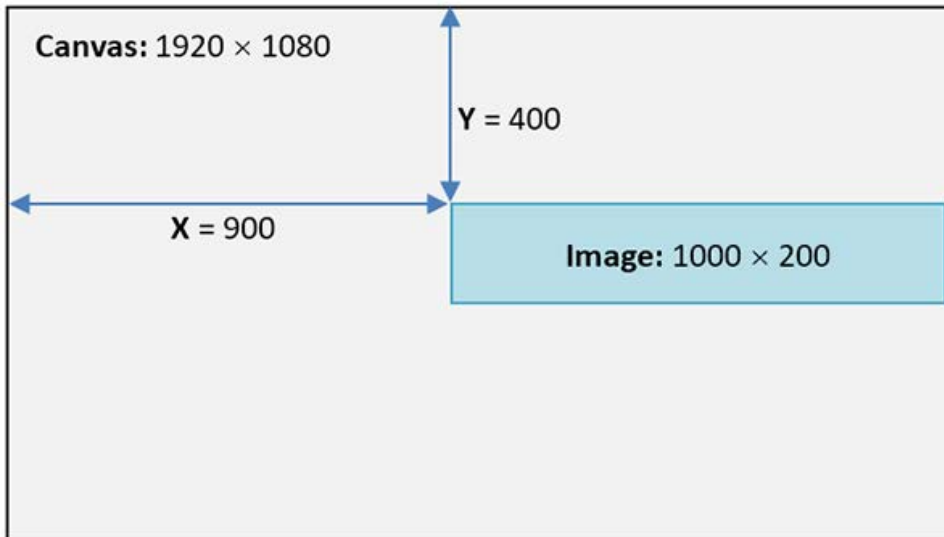

### Coordinates relate to Centre

This defaults to off, where the X and Y values describe where the top left of the visual resource is positioned. If checked, X and Y describe where the centre of the resource is located.

### Screen Location: Dome mode

Dome (Frustum) mode is a special geometric mode in which resources are rendered onto a 3D world, so they are placed and sized in terms of angles instead of pixels.

➤ [Display Configuration: Dome Mode](#) <sup>193</sup>

## Resource Layout

---

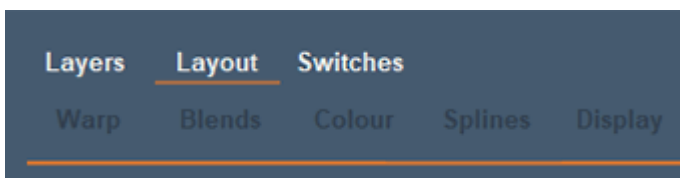

Choose *View > Resource Layout* from the menu to access this window which shows a 2D basic representation of the Flat canvas and resources, enabling you to add, move and resize visual resources (Movies, Images, Text and Video capture) directly on the canvas.

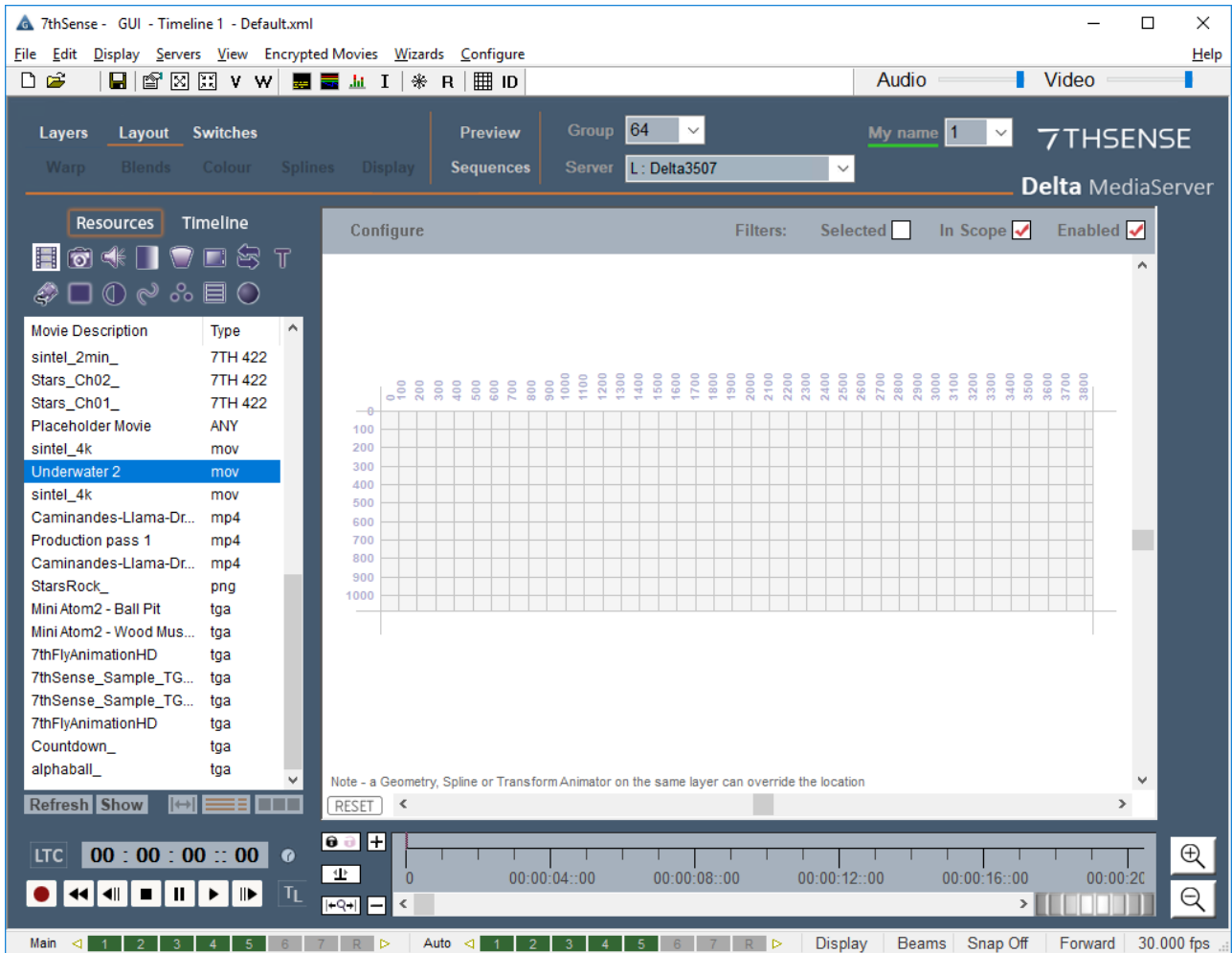

**Note** that this only works in Flat modes (including Mesh Mode), not Dome mode.

Drag resources from the resource pool on the left onto the canvas. Resources are initially full-screen by default, so click the maximize / windowed button (top right of the resource) to allow resizing and moving. This view is fully interactive with the playback window (inset below).

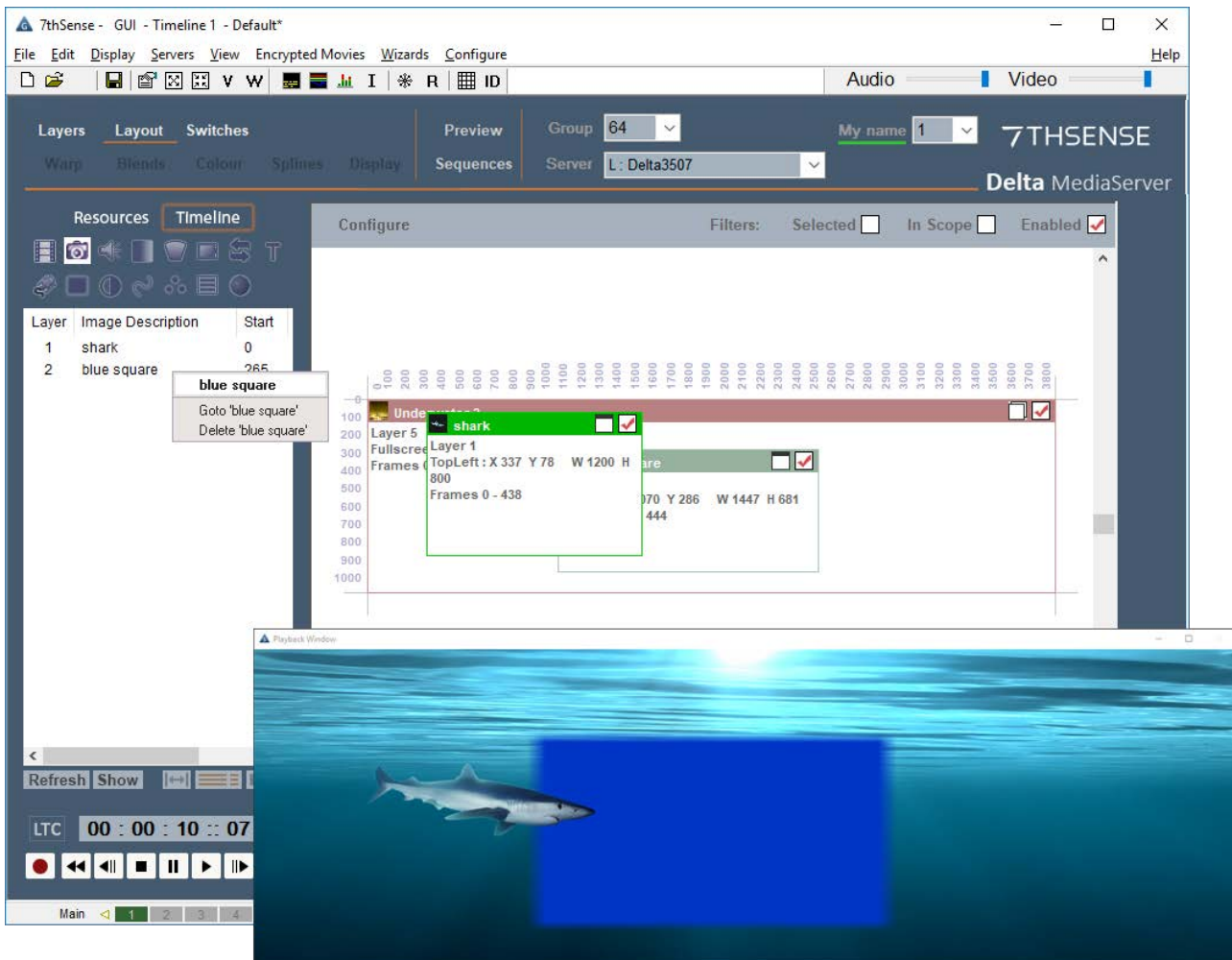

Click the resource pool 'Timeline' to view only resources that are on the timeline, hover the name there for **properties**, double-click to **edit**.

Right click a resource in the pool list (illustrated above) to **go to** that resource's position on the timeline (if not in scope), or to **delete** it.

Resources are added sequentially on top of each other in Layer1. To change layering, double-click the title bar of a resource to access the Resource Editor.

Click the **Enable** tick-mark in each window's top right corner to enable or disable that resource in the timeline.

## Filters

Choose **Enabled** to only show enabled resources.

Choose **In Scope** to only show those resources which are visible at the current timeline time.

Choose **Selected** to only show one resource at a time in the layout window so that you can work with overlapping resources – simply choose the resource from the left resource window, then you can move that single resource. The resource will also be Outlined automatically once selected, and all others deselected for outlining.

## Configure (Menu)

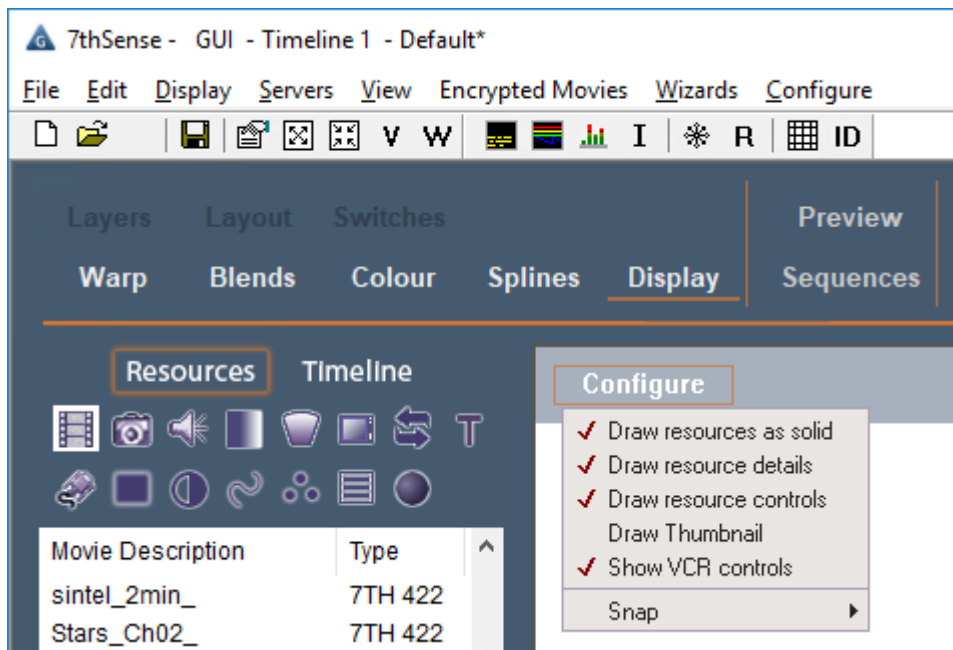

### Draw resources as Solid

If disabled, the resource windows become see-through, allowing you to move a resource which is on a lower layer.

### Draw resource details

Show the resource layer, coordinates within the resource window

### Draw resource controls

Show the enable / maximize control in each resource window.

### Show VCR Controls

Show the playback controls to enable moving the play head.

### Snap

Enable or disable snapping points to the grid.

### RESET Button

Resets the view so that the canvas is shown full screen.

## Sizing and Zoom Control

### Aspect ratio

When resizing, hold the Shift key down to lock the resource to its original aspect ratio.

### Grid snap

When moving or resizing with the grid on, press the Ctrl key to temporarily ignore the snap function.

### Zoom

The mouse wheel will zoom in / out about the cursor within the layout window.

## Notes

- Enabling a movie while playing may not work, depending on the disk system.
- The position on the canvas as shown may not represent the true position as seen in the server playback window, since other resources (geometry, spline, transform animator) can override the position set within the resource.
- Once a resource is selected, also move it with the arrow keys, and press Control while using the arrow keys to move by 10 pixels a time.

## Animation

Basic animation is available for Movies, video capture, text and Images, and sets the rate and angle at which the image moves and rotates. Double-click the Timeline Resource for the editor:

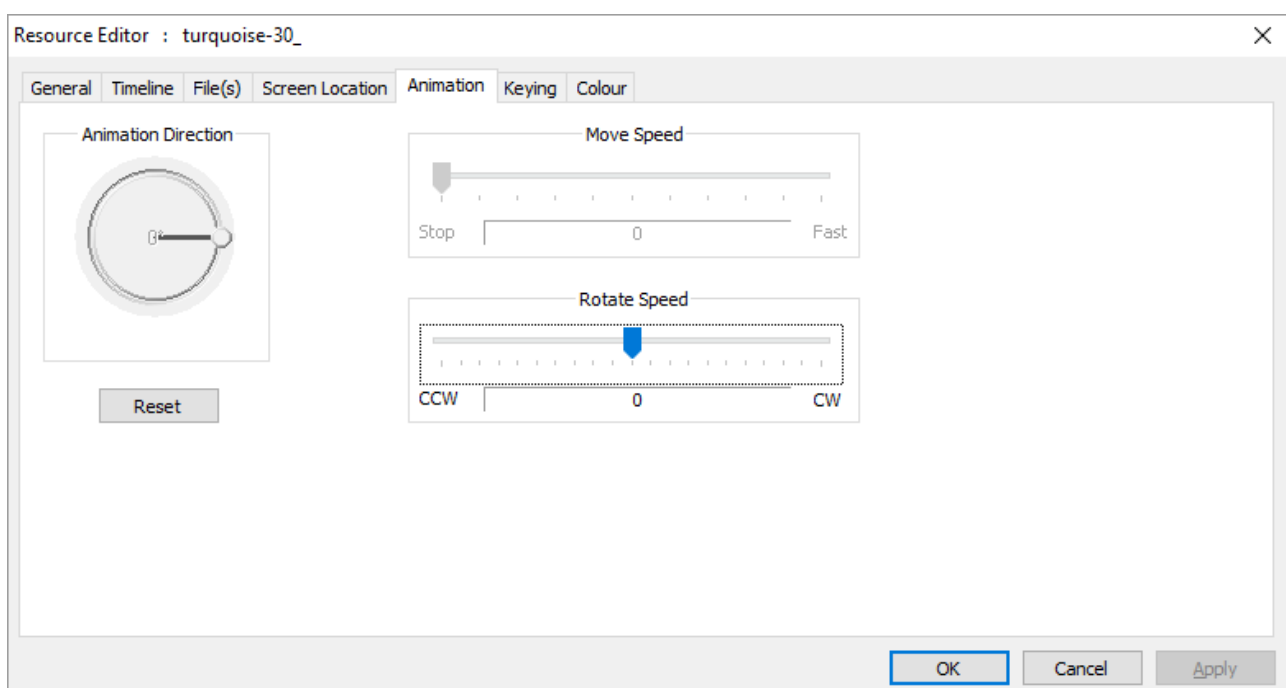

Note that the animation is frame-based, so the timeline has to be playing in order to see the animation. This also means that the animation is dependent on the actual frame number, so that on multiple racks, the look of the image is consistent at a particular frame.

Movies and Video Capture only have rotational animation.

## Transform Animation



Adding a Transform Animator (TA) to a layer affects all resources on that layer while it is in scope. This resource effect provides Flat Plane transformation of X, Y, Width, Height or Roll so that users can quickly create motion effects for a whole layer without creating complex geometry resources.

**Note** that you can have multiple TAs on the same layer, doing different things as required, so for example, one TA in speed mode, animating the position of X and Y, with a second TA on the same layer in Absolute Mode, animating W and H over a different time.

### Transform Animator: Absolute Mode

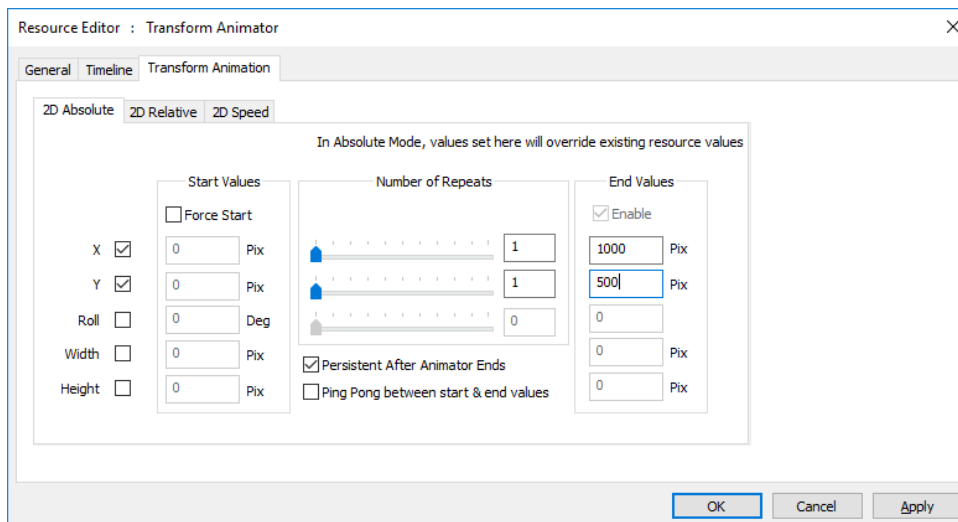

The three blocks represent start values, iterations (repeats of the action during the length of the transform animator), and end values.

In absolute mode, the values entered will alter all resources directly, so for example, forced start X,Y values of 100,200 and End values of 200,200 in absolute mode will snap the top left corner of all resources on the same layer to those coordinates as the transform animator comes into scope on the timeline, then animate the resource to X=200 over the length of the TA.

- Enable which parameter (X, Y, Roll, Width, or Height) you want to animate.

- Enable 'Force Start' to set start values that override the current position(s) of the resource(s) affected, otherwise resources will be transformed from their original positions to the end position set.
- The range of iterations is 0 to 100: an iteration is a transformation between start and end values, and the time duration of the transformation is divided by the number of iterations. Note that a value of 0 means no movement will be carried out, select at least 1.
- 'Ping Pong' means that iterations alternately reverse direction.
- Start and End values are 'between' points. If '**Ping Pong**' is checked for multiple iterations, then an even number of iterations will not end at the end value of that parameter, but the start value.

#### 'Persistent After Animation Ends'

leaves the resource(s) affected in their final position.

## Transform Animator: Relative Mode

In Relative mode shown below, values entered here will be added to any resources on that layer.

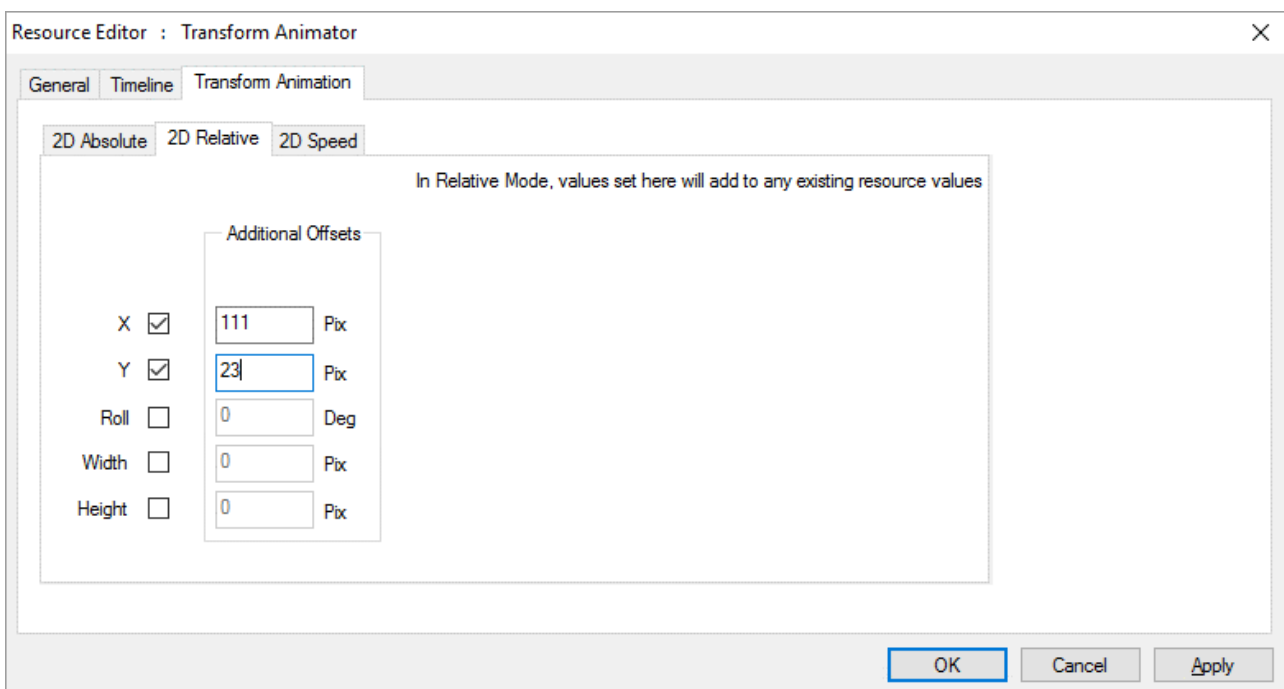

The transform animator's values can be altered from external control, simply call the TRANSFORMPARAMS transformer\_name X Y W H R control to set the values.

## Transform Animator: Speed Mode

In Speed Mode, you can set the speed of motion in both X and Y over the length of the transform animator. This allows you to animate resources onscreen at a known speed and 'Ease' in and out of a set speed from another speed or to/from stopped.

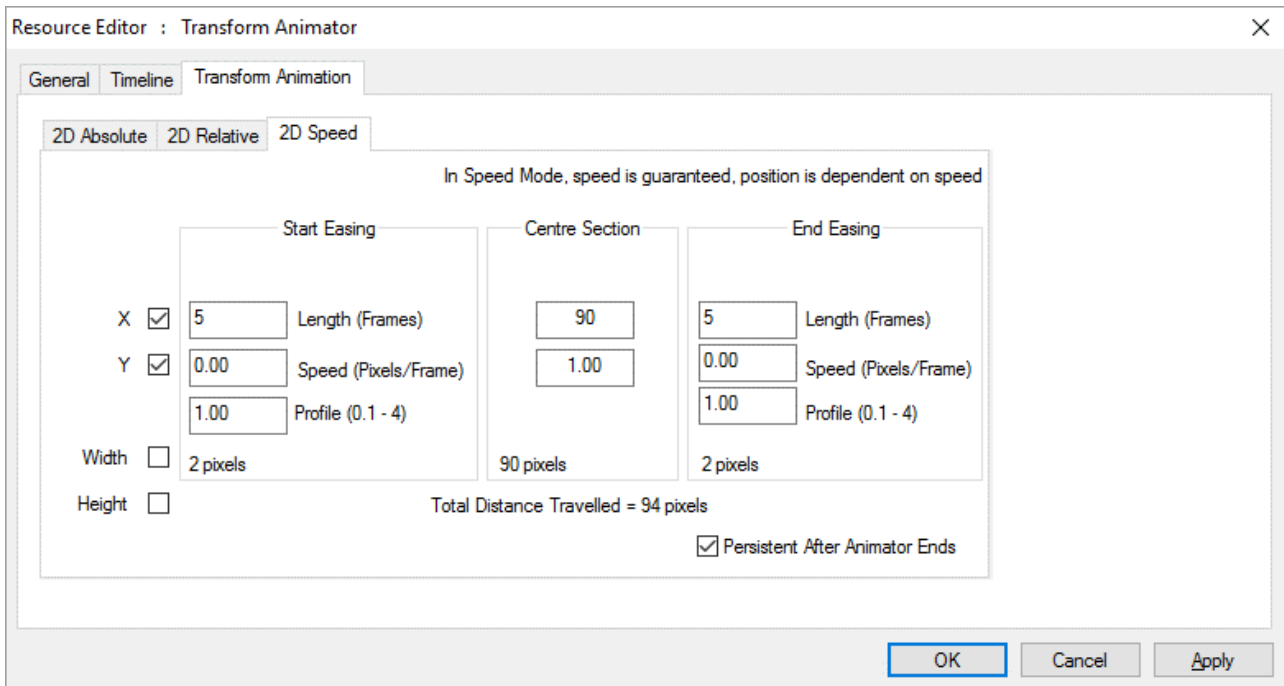

In the example above, the start speed is 0, the speed will increase to 1 pixel/frame (set in the centre section) over 5 frames, maintain that speed for 90 frames, then slow down to 0 over 5 frames. The profile sets the contour of acceleration and deceleration.



## Geometry/Warp

After adding a Geometry resource to the timeline media layer, select **Warp** from the Workspace Menu to access the geometry configuration panel. Geometry can be applied to a specific channel for display alignment (place it on the background layer), or it can be applied to a piece of media across the whole canvas by placing it on the same non-background layer as the media.

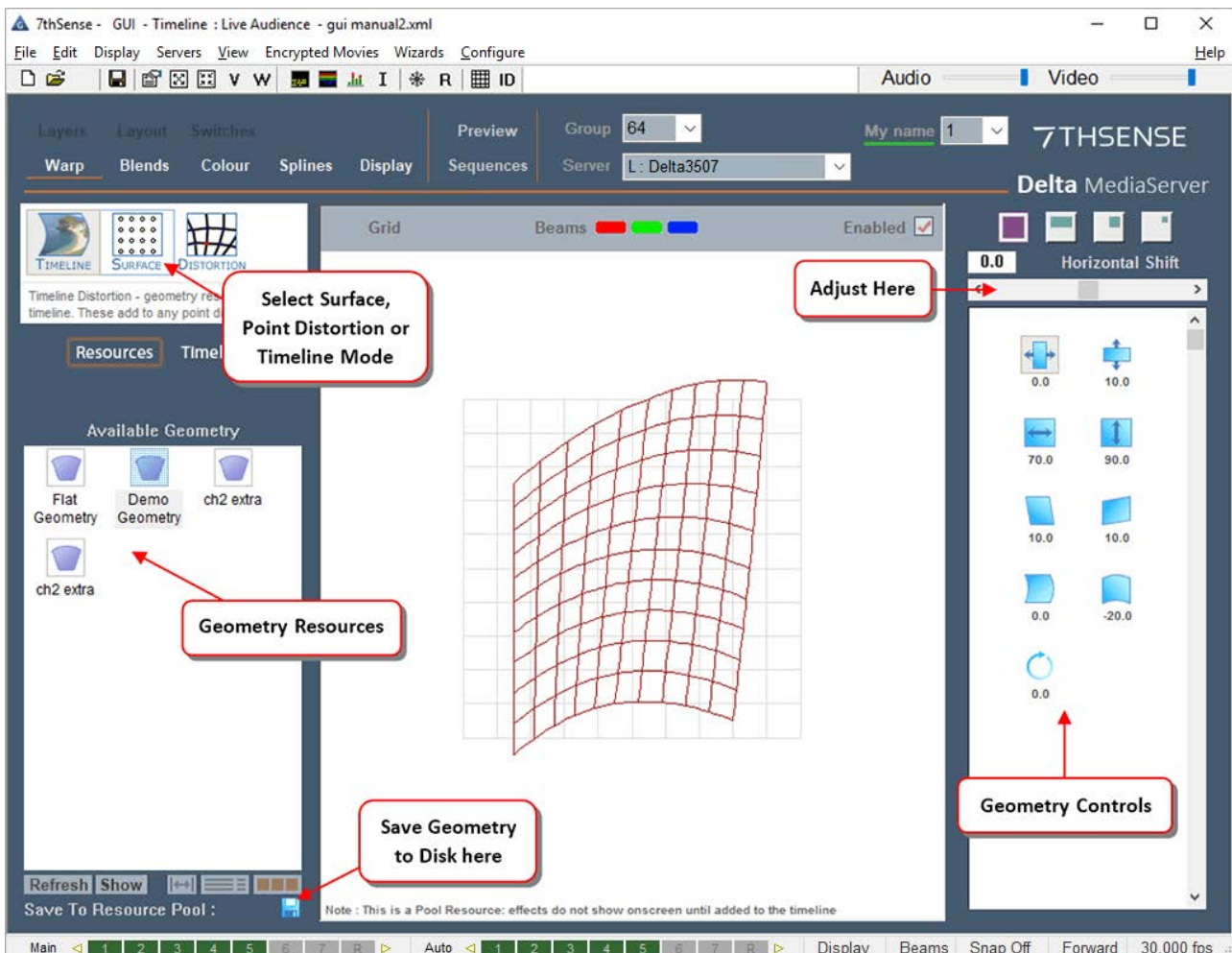

Timeline (i.e. used and edited) Geometry resources can be renamed, saved to the Resource Pool, or deleted.

- To manipulate a geometry on the timeline, select Timeline on the left resource area, then the relevant geometry, and manipulate it using the controls on the right side of DeltaGUI.
- If you select Resources from the resource area and adjust the warp using the right-side controls, you are adjusting a pool resource (temporarily for this session only). You may do this in order to create a specific shape, then **Save to Resource Pool** in order to store it permanently on disk. It is then available for later use by dragging it onto the timeline.

There are three kinds of geometric warping:

- **Timeline**<sup>143</sup> (bowing, skewing, stretching the image or channel)

- **Surface**<sup>144</sup> (smooth overall distortion of the image or channel around midlines and corners)
- **Distortion**<sup>146</sup> (distorting the channel as a interpolated grid, point by point, or by groups of points)

Multiple geometry resources can be applied to a timeline, and come into scope when the playhead passes the start position.

If you select a Geometry resource to **Morph**, the geometry of that layer (or the channel if it is on the background) will smoothly change shape from whatever previous geometry shape is there to be completely changed to the new shape by the start position.

Using **Morphing**, you can create nice fly-in / out effects, or shrink content down to size once something more interesting has appeared.

- The **Enabled** checkbox is used to temporarily disable geometry so you can see the undistorted image in preview mode. Note that there is a separate Enable checkbox for Point Distortion which is shown when you select that mode.

## Using Sequences

---

The sequence editor has a built-in language interpreter that allows you to write complex sequences using commands, variables and conditions.

Sequences are user-editable macros which can be called at any time from DeltaGUI or via external control. They are useful for assembling a list of commonly-used playback controls, for example:

Sequence: 'Announce'

```
Stop
Rewind
Reserve On
AudioLevel 0
Play
Delay 5s
Reserve Off
AudioLevel 10
Delay 10s
GlobalAudioFade up 5s
```

This sequence stops playback, rewinds, puts reserve mode on (an automatic fade), so the reserve timeline shows, then plays the main show again, waits 5 seconds before turning reserve mode off (an automatic fade back to the show) and restoring the audio volume setting. 10 seconds after that, the audio level is faded up to this level over 5 seconds. The reserve timeline could be playing a movie loop, or a static image or announcement, for example.

Later will see that we can be explicit about timelines, using their names, stating which timeline is stopped or played, and set our own transition effects between any timelines.

Sequences can be simple series of events that are used many times, or more complex routines using global variables and conditional statements. They can address most parameters of timeline resources by resource name, with user-defined variables, and one sequence can run another, enabling an object-oriented approach to avoid duplicating common segments. Sequences are held as individual .xml files (objects) and can be grouped in C:\sequences in branching folders.

Sequences are normally executed at 1 line per frame, to ensure smooth playback. However, a lengthy sequence may then take too many frames to execute fully. To shorten this duration, groups of lines can be executed as a single line in a single frame, by using the **\$startblock** and **\$endblock** keywords before and after the lines to be run together.

Note the other special keyword here: **\$persistsequence**, which ensures the sequence will not be dropped when a new show file is opened.

## Ways of Using Sequences via External Controls

Sequences can be run or triggered in a timed, triggered or manual manner, using:

- DeltaGUI [Sequence Editor > Run](#) <sup>363</sup> dialog
- the [Delta web interface](#) controls (Controller or Scheduler)
- [DeltaShowControl](#) with ADAM modules
- or by any other TCP or UDP connection, including Phidget controls via [7thConnect](#).

## Using Sequences on Timelines

Sequences can also be dragged onto Timeline layers from Resources [Controls] in the normal way. Therefore the sequence must first be created for selection, and named clearly for ease of use. To add a required sequence, you can double click the icon or name in the Resource Pool and add details there.

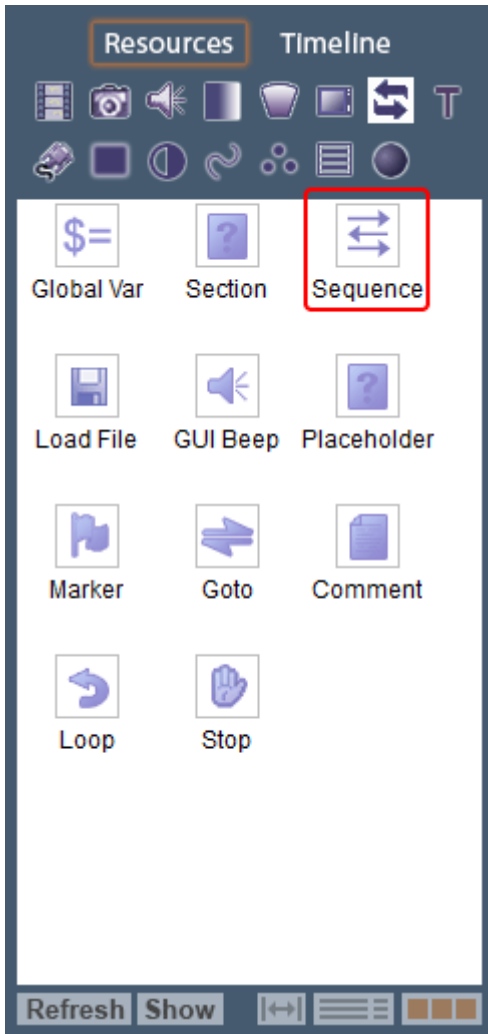

Select the required sequence from the drop-down box at the bottom:

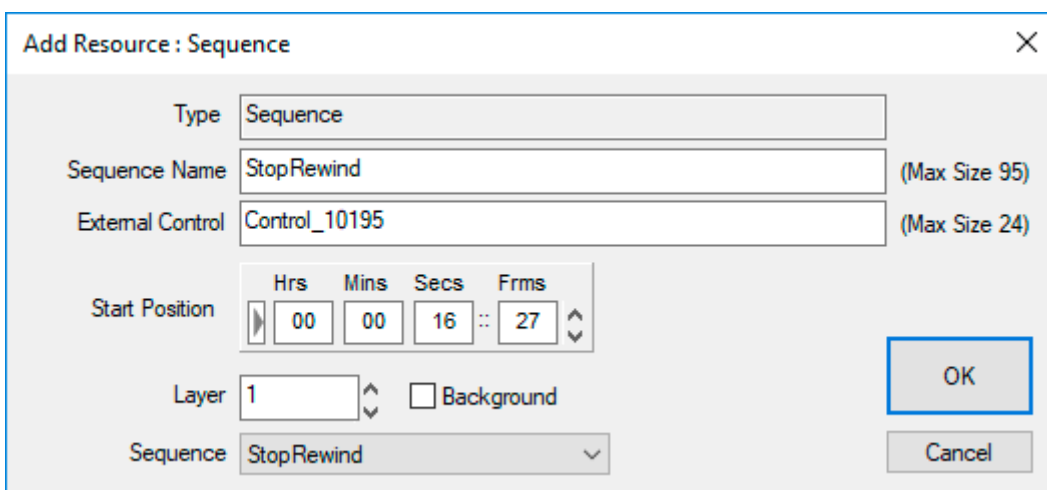

Alternatively, when a sequence icon is dragged onto the timeline, a dialog opens to select the required sequence:

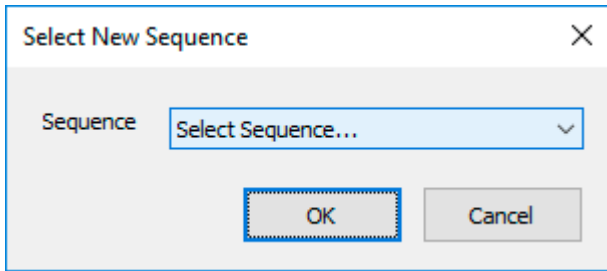

Once on the timeline, the Resource Editor can be opened and the sequence resource addressed for all its properties, and/or to select a different sequence from the drop-down list:

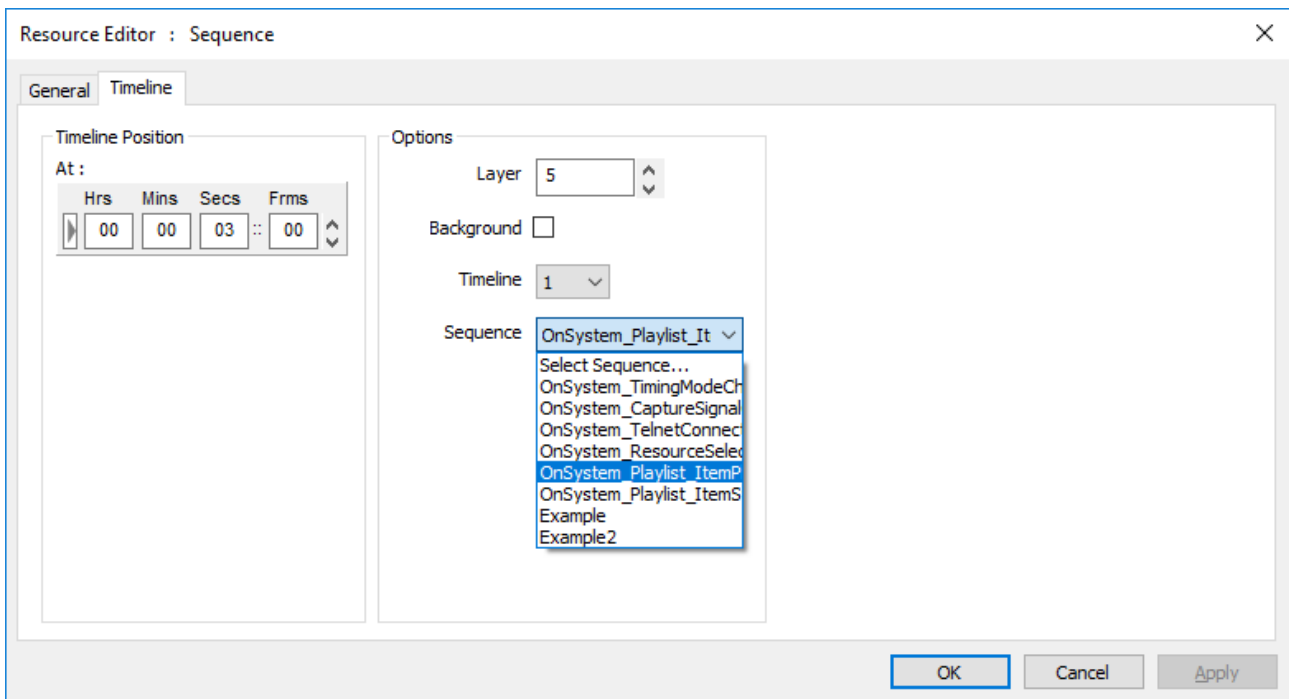

Non-sequence-specific timeline options are the same as available to any resource.

The General tab shows: that this **resource name** is a sequence type (uneditable), a reference for **external control** (editable), and the name of the **sequence** (shows the sequence selected in the Timeline tab, or if you type the correct name here, this will show in the Timeline tab).

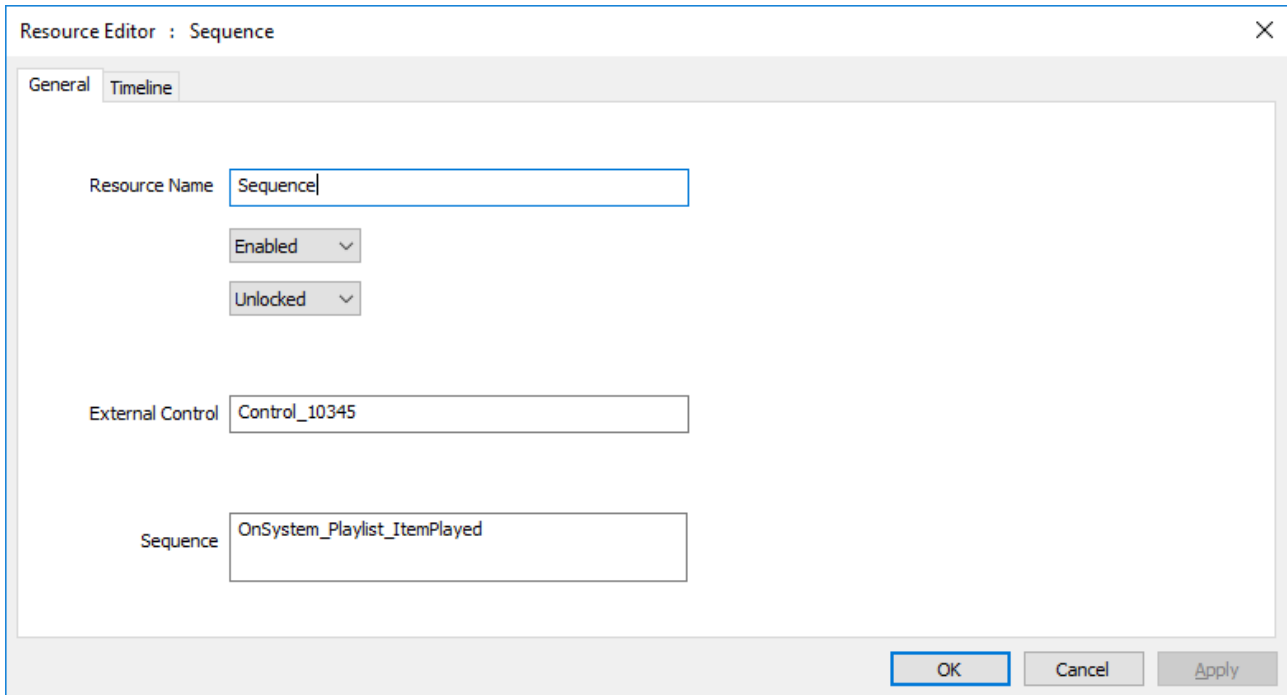

Sequences can also be used dynamically, [assigning them to buttons](#)<sup>371</sup>. They can also be triggered with external controls (e.g. using [Designer](#) widgets), or Phidget sensors and controls (using [7thConnect](#)).

Sequences are created in the Sequence Editor ([Add and Edit Sequences](#)<sup>358</sup>).

## Add and Edit Sequences

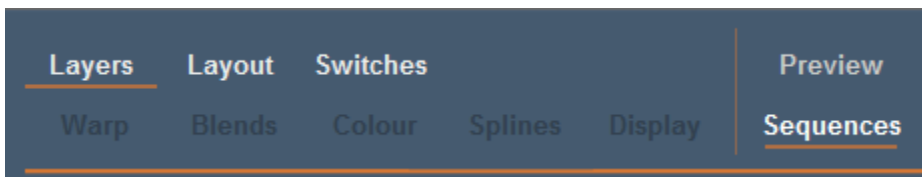

Open the Sequence Editor by clicking Sequences on the DeltaGUI control menu panel (above), or from the Main menu, *View > Sequence Editor*.

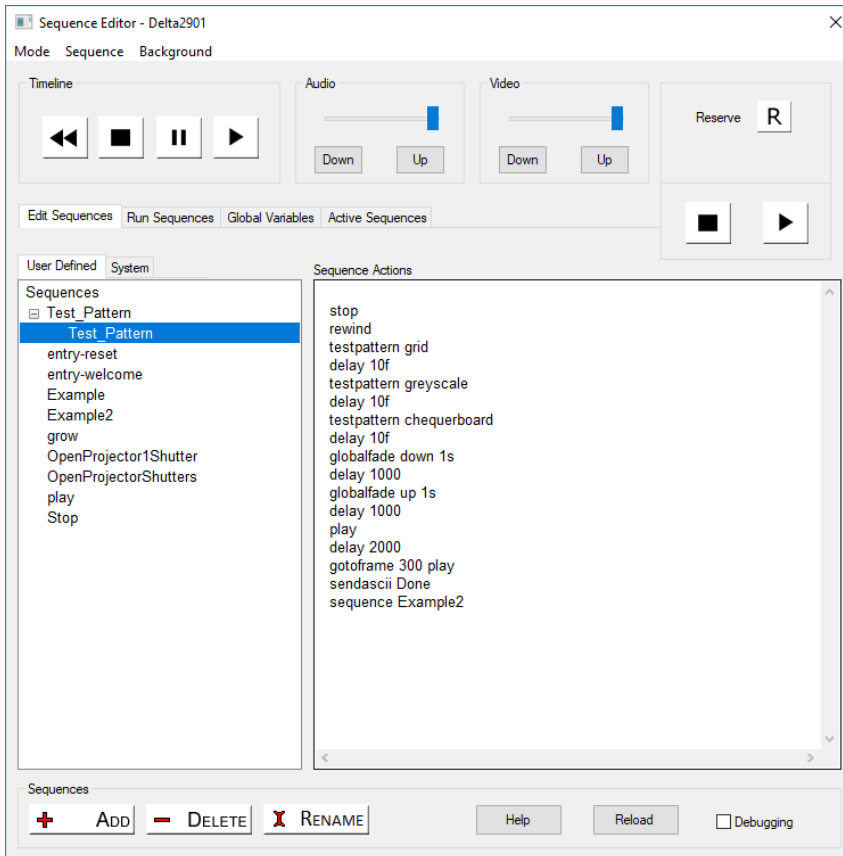

- Click 'Add' to start a new sequence. The new name will be added to the bottom of the list. To reorder alphabetically, click 'Reload'.
- Highlight an existing sequence to delete or rename it.
- If known sequences on the server do not appear, click Reload.

To group your sequences by function (for example) add a new or existing subfolder to the sequence name when you create it:

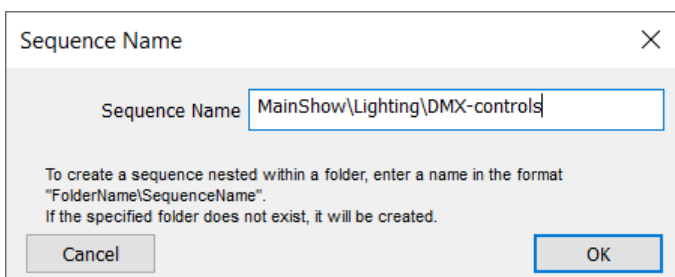

From here, you can control the timeline, change resource parameters, the video and audio levels, whether to go into reserve mode, add or delete sequences, and edit the content of each sequence. By default, sequences are held in the C:\Sequences folder(s), one sequence per XML file.

When run, a sequence affects the server that it is on. Where there is a Leader-Follower relationship, the same commands can be phrased as ASCII-UDP instructions to the IP addresses of Followers.

**What commands can you use?**

Click the **[Help]** button for the list of **external control commands**, annotated for those that are non-sequence, or sequence-only commands. Examples of use are given, with basic rules in the header to the Help page. This page on your server will relate to the version of Delta you are using. A few commands may not be available in other versions.

Here are some example commands:

**EYEGOTOXYZ x y z**

Move the interactive mode eye-point to X Y Z (in mm)

**EYEGOTOXYZAZEL x y z h p r**

Move the interactive mode eye-point to X Y Z (in mm)  
Heading, Pitch and Roll (in degrees)

**DELAY time**

Delay the sequence for the amount of time specified. This can be written as 100ms, 1.2s or 100f for 100 frames.

**SENDASCII text telnetport**

Send this text out of the Telnet port.

**SENDASCIIUDP ipaddress port ascii**

Send the ascii string to the ipaddress and UDP port

**SENDASCIISERIAL Comport baudrate parity databits stopbits ascii**

Send the ascii string to the Comport.

**Version 2 SENDASCII Format****SENDASCII2 data="any text" port=telnetport**

Send this text out of the Telnet port, note that it is 1001 for the first connected device on a multi-Telnet port, 1002 for the second etc.

**SENDASCIIUDP2 data=text ipaddress=ip port=theport**

Send the ascii string to the ipaddress and UDP port

**SENDASCIISERIAL2 data="any text" port=theport baudrate=thebaudrate parity=p databits=n stopbits=s**

Send the ascii string to the Comport with the parameters specified

**SENDASCII2 Examples**

SENDASCII2 data="some text \x0d" port=1002



SENDASCIUDP2 data="some text \x0d" port=1002 ipaddress=10.100.101.102

SENDASCIUDP2 data="some text \x0d" port=\$myport ipaddress=\$myipaddress

SENDASCIISERIAL2 data="some text \x0d" port=COM2 baudrate=38400 parity=n databits=7  
stopbits=1

**TESTPATTERN name**

TESTPATTERN pattern=crosshatch x=50 y=20 or TESTPATTERN pattern=pixelgrid enable=true

**BEAMS [r g b rg rb gb rgb ]**

Set the overall beams

**GEOMETRY [ on/ off ]**

Set the overall geometry on or off

**BLENDS [ on/ off ]**

Set the overall blending on or off

Sequences can be called from external control via the Sequence or SequenceAll command; you can also list the available sequences using ListSequences, and reload them using ReloadSequences.

## Debug Sequences

Select the Debugging checkbox (bottom right) to show the Watch and Trace windows (right) on the sequence editor. These will show in all the sequence tabs:

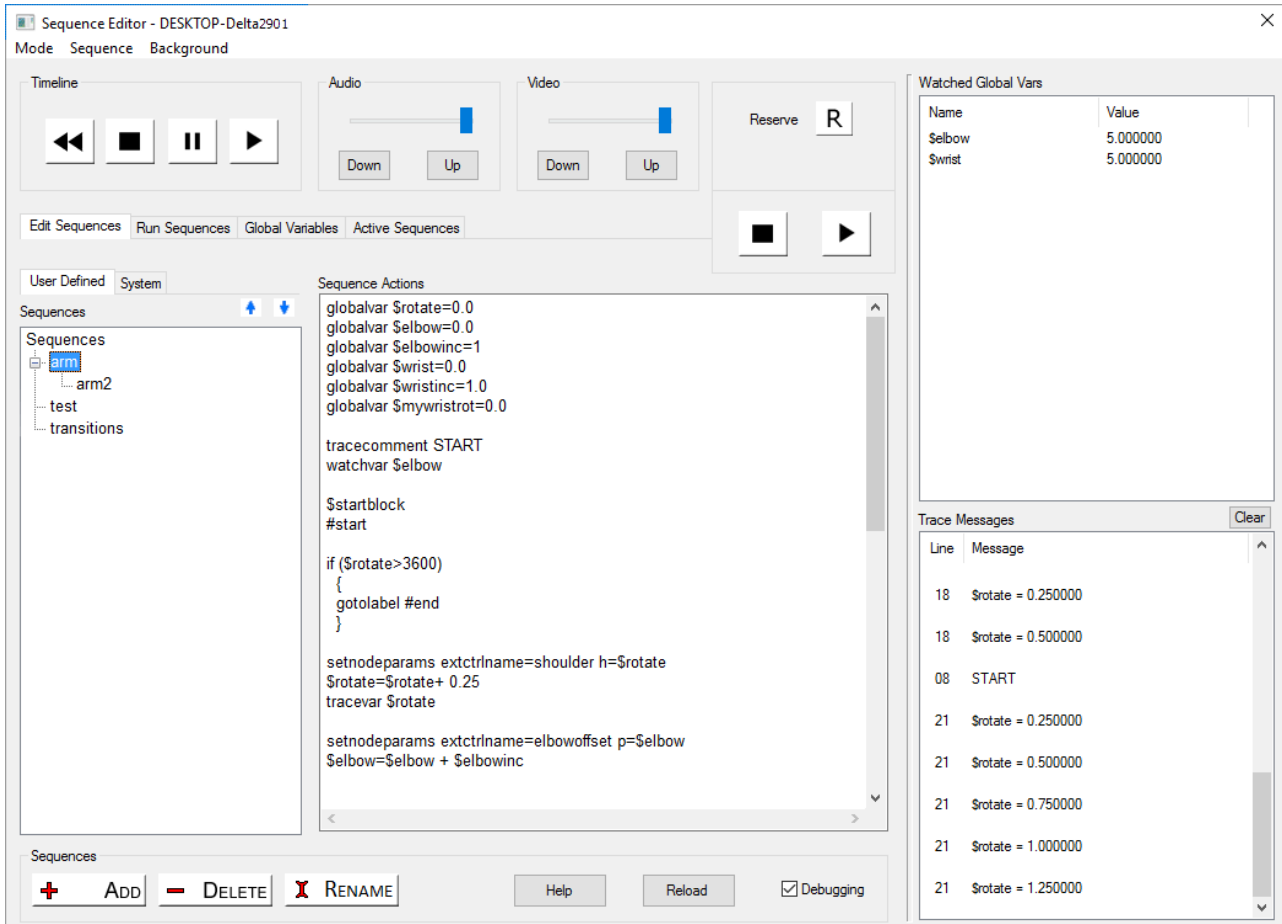

In the sequence above, the Tracecomment command sends any text to the Trace window, the Tracevar command sends the value of the \$myipaddress global variable and the watchvar command sets the \$count global variable to be shown in the Watched Global Vars window.

## Debugging Commands

### Traceclear

Clear the trace messages window

### Tracelist

Output a list of global variables to the trace messages window, optionally only the Watched variables

### Traceon

Turn on tracing

**Traceoff**

Turn off tracing

**Traceseqname**

Trace the current sequence name to the trace window

**Tracenoncode** [off/on]

Show every active line of the sequence (not including code lines) in the trace window

**Watchclear**

Clear the watched variables

**Watchvar \$variablename** [off / on]

Turn on or off Watching for this variable

**LOG message="[string]" file=[c:/filename.txt] timestamp=[y/n] level=[level]**

Log a message. File is optional and can be a relative or absolute path to a file, if no file is given the message will log to the delta log file, the directory must already exist. Optionally timestamp, default is to add timestamp. Optionally record a level, level can be NOTE, WARNING, ERROR, FATAL

## Run Sequences

By choosing [Run Sequences] from the Sequence Editor, a set of 100 buttons are presented in 5 pages. You can set each one to any of the available sequences for immediate use.

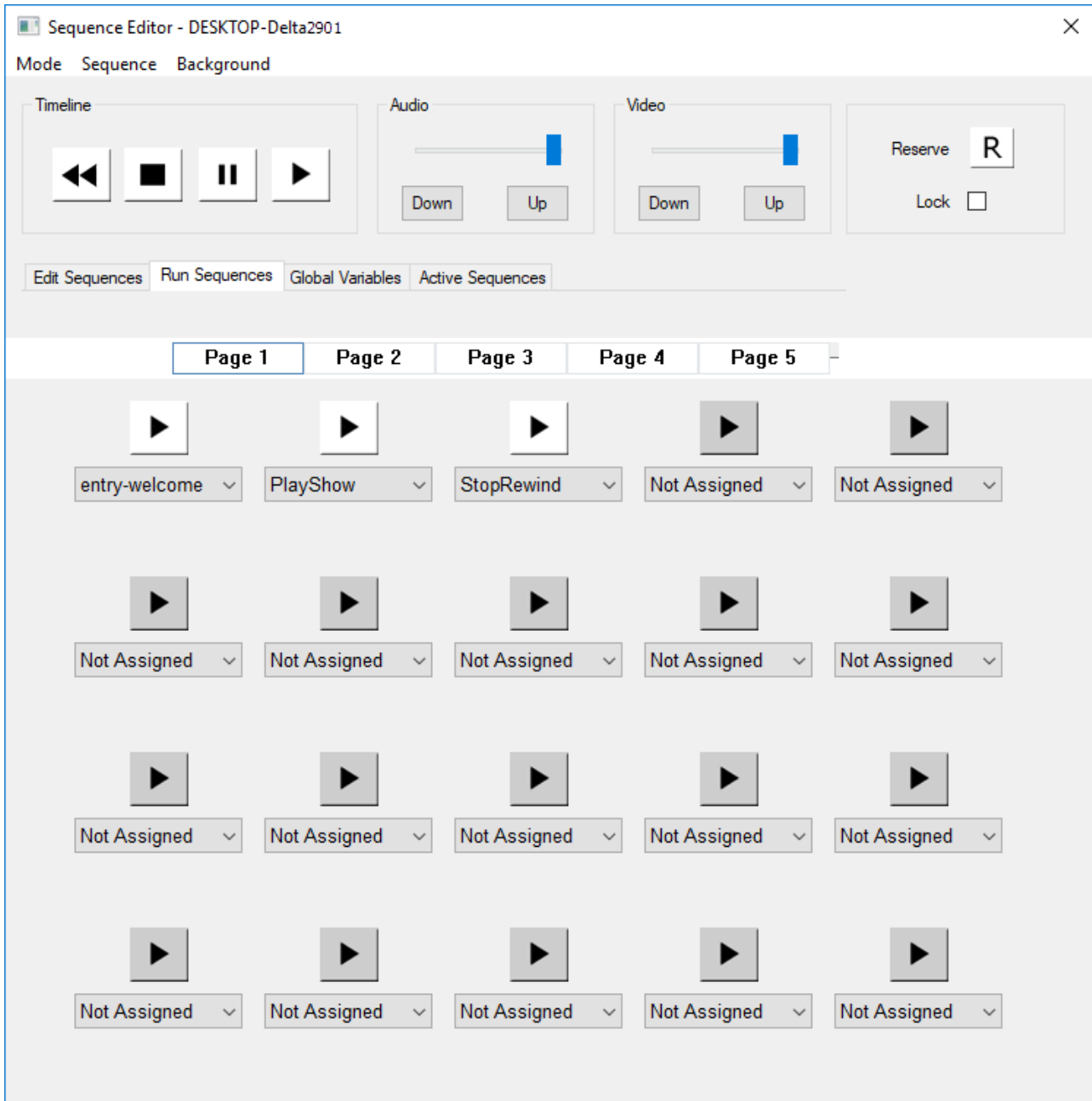

To make the pages distinctive, each one can be given a different background image (.BMP only). Select *Background > Load Image* for the background and *Draw Box Background* to give a contrasting background to the sequence names. Backgrounds only show when the Lock checkbox (top right) is selected.

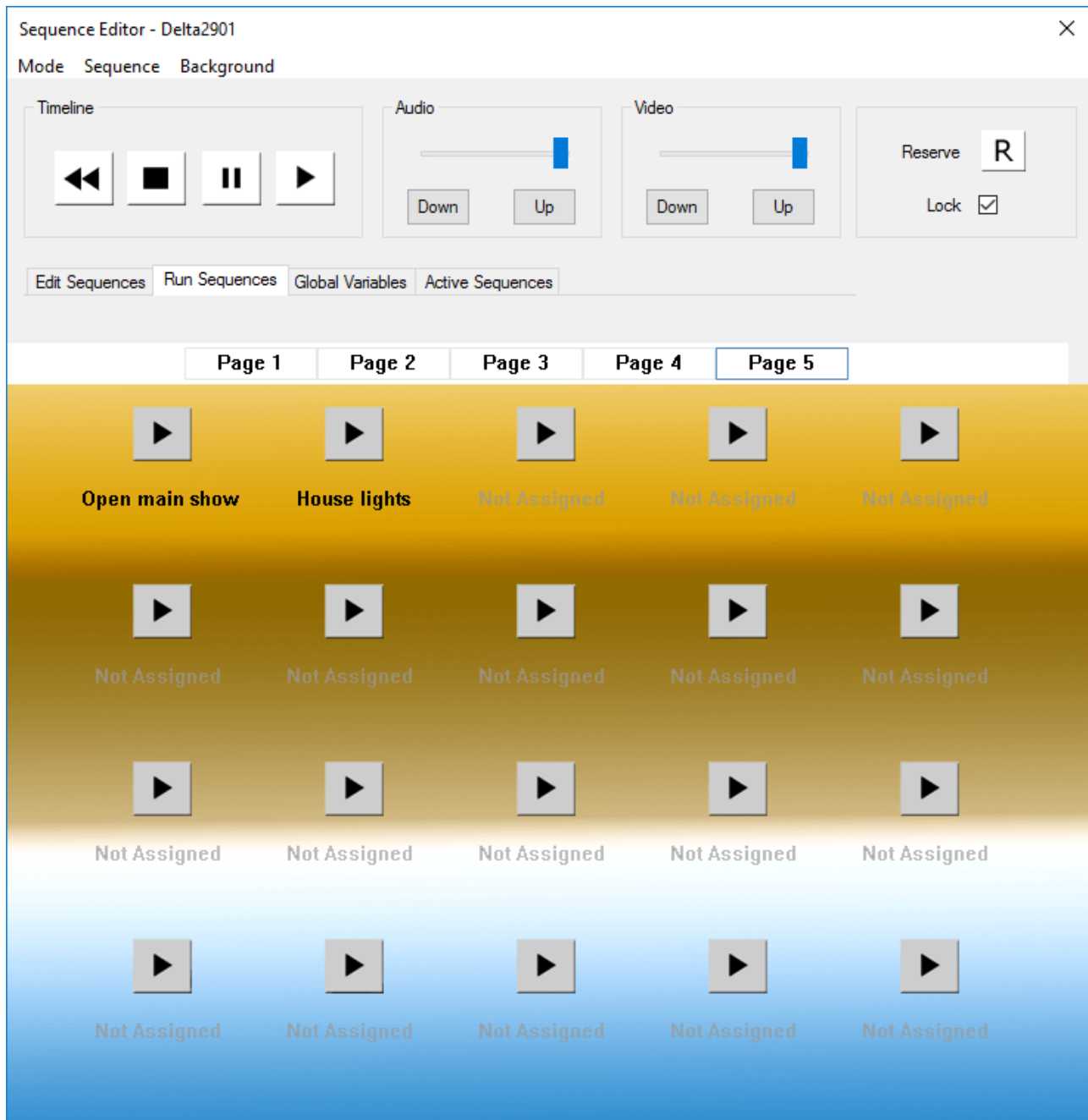

## Global Variables

You can add and use your own variables that can be used in any sequence. Select the Global Variables tab in the Sequence Editor and click the + Add button. These variables are created in the server and persist after closing.

The same dialog can be returned to, to edit a variable, by double clicking the variable name:

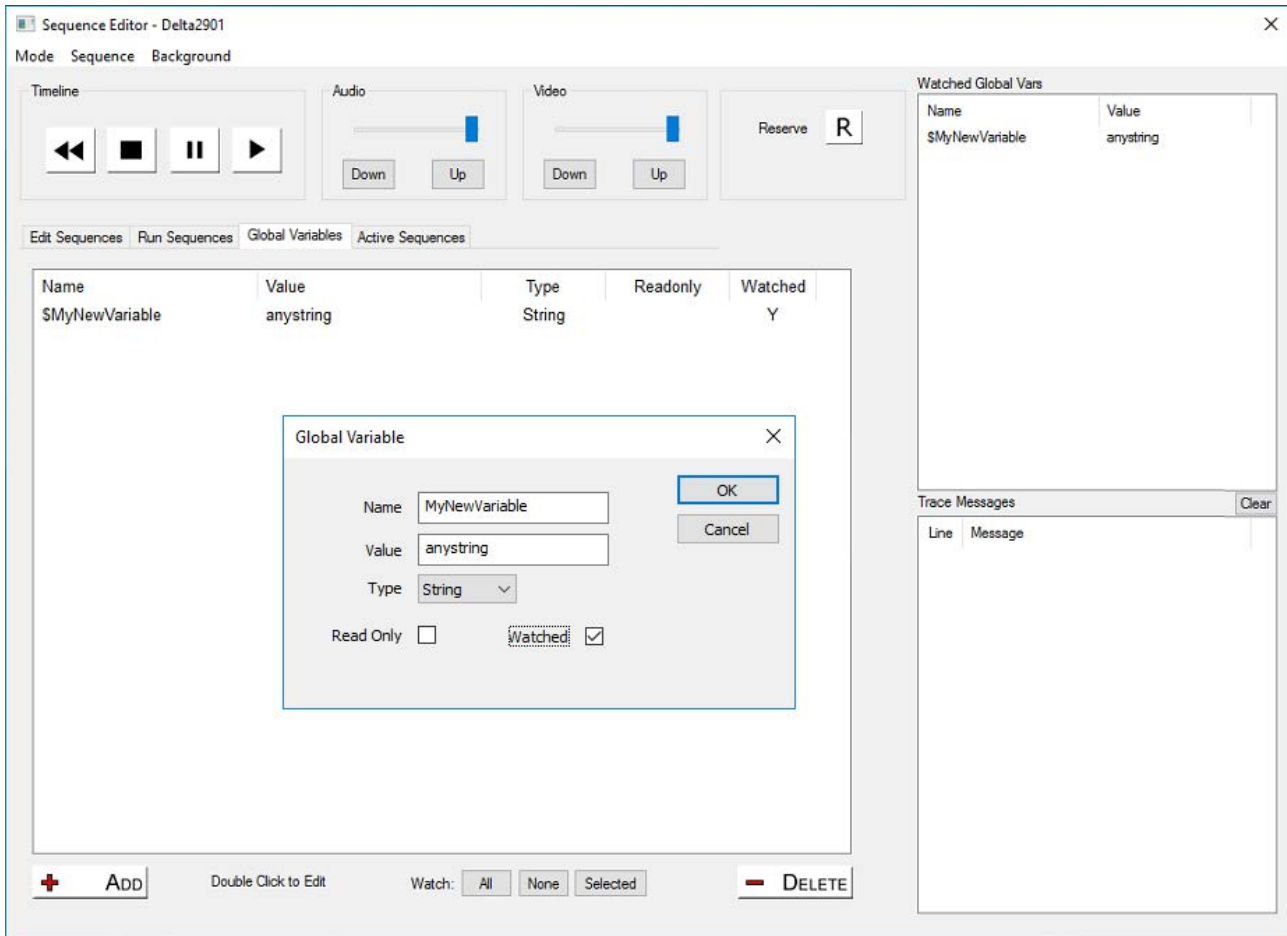

Variables can also be created, set and read by sequences (see: 'Global Variable Commands' in [Help](#)).

## Parameters

You can choose any name for the global variable, and it can be one of the following styles:

### Int

whole number, value in the range -2147483648 to +2147483647

### Float

floating point  $1.17 \times 10^{-38}$  to  $3.4 \times 10^{38}$

### String

character array, up to 128 characters in length.

## Attributes:

### Read Only

Check this if the value cannot be changed within a sequence.

**Watched**

Check this if you want to be able to see the current value in the debugging panel (as shown above; switched on in the Edit tab).

**Using Variables**

Variables can be used in sequences to control playback or media, for example this sequence creates and initialises a global variable (similar to adding via the dialog above) to keep track of which timeline is active:

Sequence **InitialiseVars:**

```
globalvar $i_ WhichTimeline = 0
```

This sequence then uses these variables to control show playback when the sequence is triggered (from external control, from the timeline or from the buttons in the sequence editor).

Sequence **ShowControl:**

```
if ($i_ WhichTimeline =1)
{
  play tl=2
  sequence TL1AudioDown
  sequence TL1VideoDown
  delay 1000
  stop tl=1
  $i_ WhichTimeline =2
}
else
{
  play tl=1
  sequence TL2AudioDown
  sequence TL2VideoDown
  delay 1000
  stop tl=2
  $i_ WhichTimeline =1
}
```

This sequence interrogates the \$i\_ WhichTimeline variable and if it is 1, plays timeline 2, triggers off other sequences which fade down timeline 1, then stops timeline 1 after a delay. It then sets the \$i\_ WhichTimeline to 2 so that the next time the same sequence is called, the Else part is called to reverse the actions and start timeline 1 while stopping timeline 2.

A further example is a realtime clock, where a text resource is placed on the timeline and this sequence is triggered (once only, since it keeps running) to update the text resource contents with a string representing the current local time:

Sequence **RTC**:

```
#start
$mystringvar2=$currenttime
textparams MyRTC $mystringvar2 150 255 255 0 tl=1

Delay 500ms
gotolabel #start
```

In this sequence, the \$mystringvar2 is a String type variable (previously created in a sequence or the editor), and it is set to the reserved variable '\$currenttime' which fills it with (for example) 10:20:41. The Textparams command then sets the resource named 'MyRTC' to this value and the text size is 150, the colour is 255,255,0 (yellow) and the timeline is 1.

## Code Syntax

### Comment

Can have full line comments like this or  
\$myvar = 2 // after the code comment

### Compare

valid tests = != and or < >

```
if ($myvar = $myvar2)
```

```
if ($myvar = 2)
```

```
if (2 = $myvar)
```

```
if ($myvar > $myvar2)
```

```
if ($myvar and 2)
```

```
if ($myvar!=2)
```

and/or only work on Int type variables

greater than or less than work on int or float type variables

### Add, Subtract, Multiply, Divide

```
$myvar = $myvar2 + $myvar3
```

```
$myvar = $myvar2 + 2
```

```
$myvar = 2 + $myvar2
```

The above lines can use + - \*/



## Concatenate arguments and strings

Addition with string variables concatenates them. Adding an int or a float to a string will concatenate the int or float as a string.

```
mediainsert resourcename = $thisClip + $thisVersion
mediainsert resourcename = $thisClip + $thisVersion + "_444"
mediainsert resourcename = $thisClip + $thisVersion + '_444'
load "C:\\Shows\\" + $showName
```

Use to concatenate the values of variables as strings, and explicit strings, within the argument of a function. Explicit strings can be enclosed by single or double quotes.

## Create Global Variables

Global Variables can be int, float or string

```
globalvar $myintvar = 1
globalvar $myfloatvar = 6.54
globalvar $mystringvar = "movie"
globalvar $myintvar = 1 readonly
```

Adding readonly will create a variable with that value, which will not be written to the registry thereafter.

Creating a global variable which already exists will do nothing.

## Set a Global Variable

```
$myintvar = 12
$myfloatvar = 16.54
$mystringvar = "movie2"
$myvar = $myothervar
```

## Special Variables

```
$myvar = $seqrandom[4,40]
    Sets $myvar to a random value between 4 and 40
$myvar = $absoluteframe[2]
    Sets $myvar to the current absolute frame of timeline 2
$mystringvar = $absoluteframe[1] smpte
    Sets $mystringvar to the current absolute frame in smpte mode of timeline 1
$mystringvar = $absoluteframe[1] digits=5
    Sets $mystringvar to the current absolute frame formatted to 5 digits where possible
$mystringvar = $currenttime
    Sets $mystringvar to the current clock time of the server
$mystringvar = $currentdate
    Sets $mystringvar to the current date in dd/mm/yyyy
$mystringvar = $currentdate usa
    Sets $mystringvar to the current date in mm/dd/yyyy
$replacevarmode = [0/1]
    0 is the default search replace mode, 1 is a simple string replace mode
```

## Special Keywords

\$persistsequence

Adding this keyword to your sequence will call this sequence to persist through filenew / open.

\$startblock

All lines up to \$endblock are completed in 1 frame

\$endblock

All lines from start block up to \$endblock are completed in 1 frame

**Note** : do not put Gotolabel loop inside start/end block as this will cause high CPU use.

## Increment / Decrement

\$myval++

\$myval--

## Conditional Branching

if (condition)

    // Do something

else

    // Do something else

Multiple if or if-else blocks are allowed, no nesting is allowed

## Jump to lines

#start // label is designated by #

\$myintvar = 12

if (\$myintvar>0)

\$myintvar--

// do something 12 times

gotolabel #start

**Note**: the full list of sequence code supported is accessed from the *Sequence Editor* > [Help](#) button.

## Active Sequences

Sequences that are running are shown in this dialog. When you run a sequence, it is given a unique name of SequenceName\_X where X is an internal counter. To cancel a specific sequence, right click on it in the list and select cancel, or from external control call CANCELSEQUENCE entry-reset\_1 from the list below. To cancel all sequences, call CANCELALLSEQUENCES.

**Note** that this list is updated every 1 s.

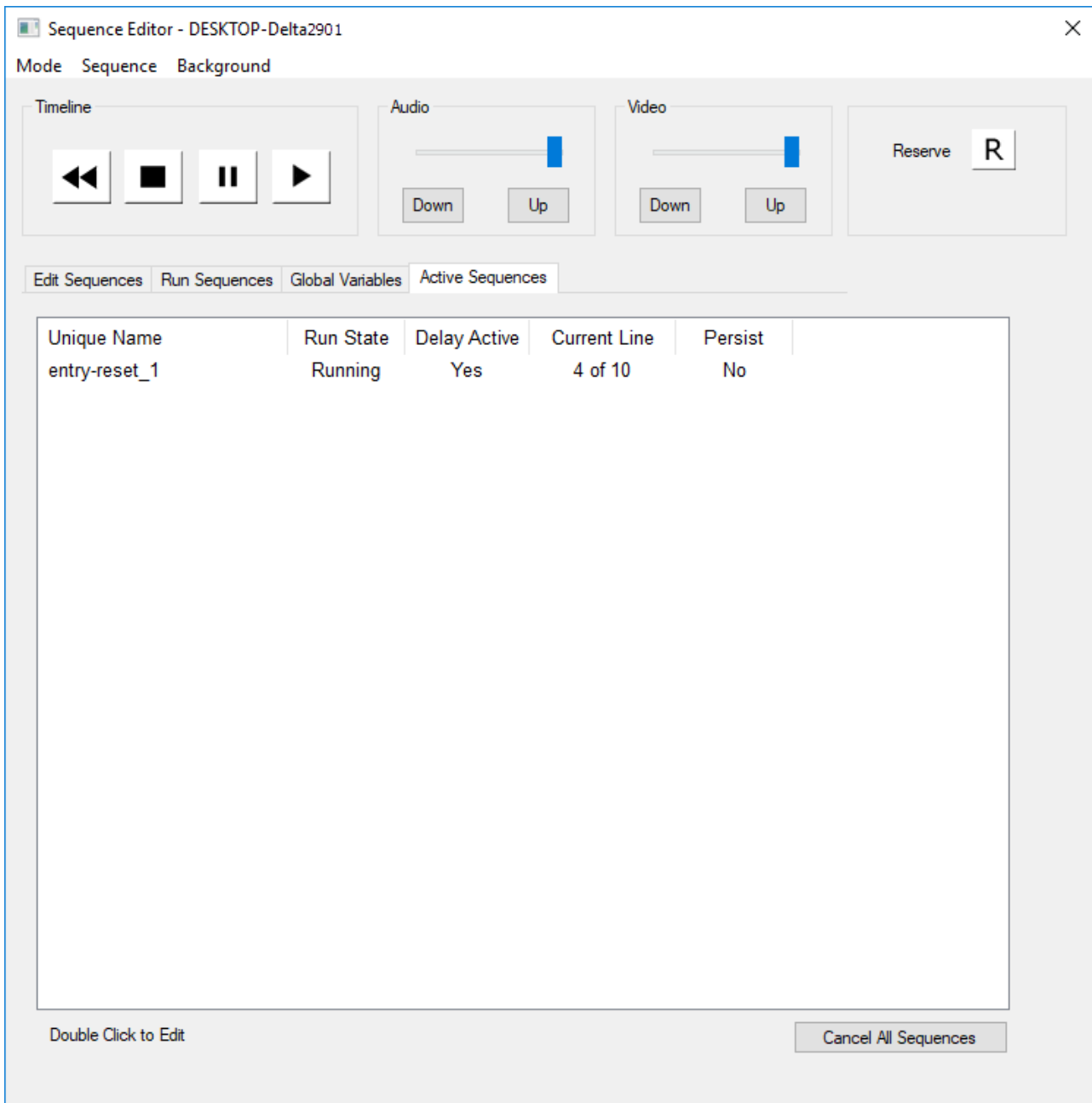

## Sequence Panel: Apply Sequences Dynamically

The Sequence Panel enables sequences to be applied and triggered manually from assigned **buttons**, irrespective of any sequences applied to layers in a timeline. Indicators in the lower half of the panel can be used to show any text or the value of any global variable and separately: set the related LED to a specific colour.

To open the Sequence Panel, from DeltaGUI menu, *View > Sequence Panel*.

This shows on the right side of DeltaGUI and contains 6 initially blank, user-configurable buttons and 6 user-settable indicators for quick access to frequently required sequences.

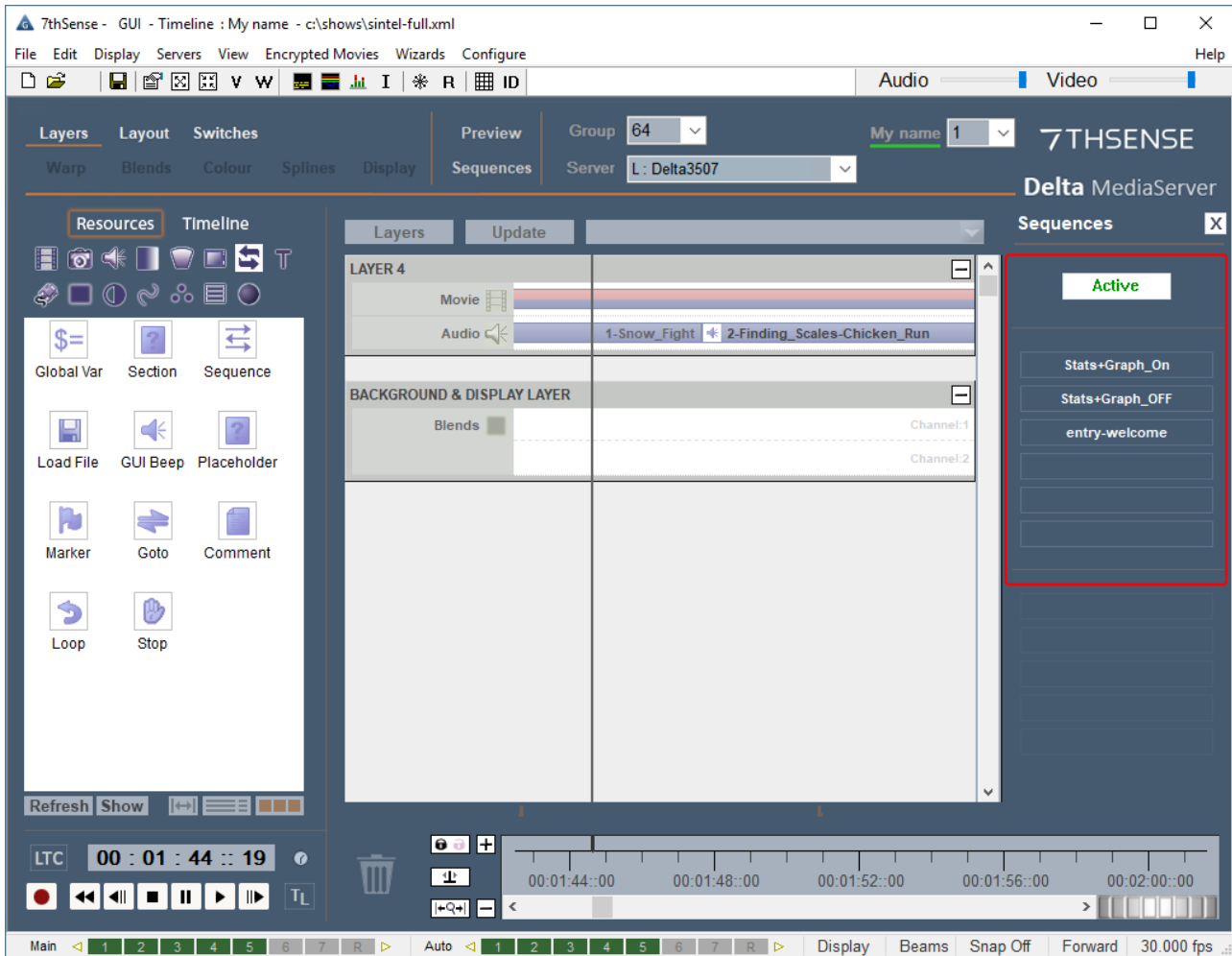

## Assigning Sequence Buttons

The 6 sequence buttons can be assigned in two ways, using the mode button which cycles between Active, Choose, and Edit mode.

### Choose

click the button to which you want to assign a sequence, and from the drop-down list of all sequences on the server, select the one you want.

### Edit

click the button you want to edit, and type in the name of a sequence. This can be the name of a sequence you have yet to create.

Return to Active mode and **save the assignment by saving the show**. Buttons with active, assigned sequences will now run them when pressed.

You can also set the buttons from a sequence, for example:

```

panelsequence index=1 sequence="ENABLE COMMS"
panelsequence index=2 sequence="DISABLE COMMS"
panelsequence index=3 sequence="MeshMove"
panelsequence index=4 sequence="MeshRewind"

```

## Sequence Indicators

The sequence indicators can be accessed from a sequence, to set the colour of the LED or the text in that slot:

```

$teststring = "My Indicator Text"
$replacevarmode = 1
SEQUENCEINDICATOR index=1 text="$teststring" state=none

$smpte = $absoluteframe[1] smpte
SEQUENCEINDICATOR index=2 text="$smpte" state=none

$myvariable=0
SEQUENCEINDICATOR index=3 text="My Variable 1" state=$myvariable

$myvariable=1
SEQUENCEINDICATOR index=4 text="My Variable 2" state=$myvariable
SEQUENCEINDICATOR index=5 text="Disabled Text" state=grey

```

State can be:

```

off, 0, false, red - to show a red LED
on, 1, true, green - to show a green LED
dis, disable, grey - to show a grey LED
none - to show no LED

```

**Note** the use of \$replacevarmode=1 and double quotes around the variable to preserve the whole value of the variable including spaces.

## Serial Events

Serial event devices are XML-based files which hold a human readable name linked with command bytes for the particular serial device. Permanent (open) TCP (client) connections are directed to the required permanent TCP Connection as set up in *Configure > TCP Connections* (see [TCP Connections](#)<sup>(91)</sup>).

An example of this file's contents is:

```
<COMMAND0>
```

```

<NAME> Play </NAME>
<DATA> PL\x0D </DATA>
</COMMAND0>
<COMMAND1>
<NAME> Power Off </NAME>
<DATA> \xBE\xEF\x00\x00\x00\x00 </DATA>
</COMMAND1>

```

The human readable control list is shown in a drop-down list for that serial event device, and the control codes shown below.

From this drop-down list of controls, select the control that this resource should send out when the playhead plays past it.

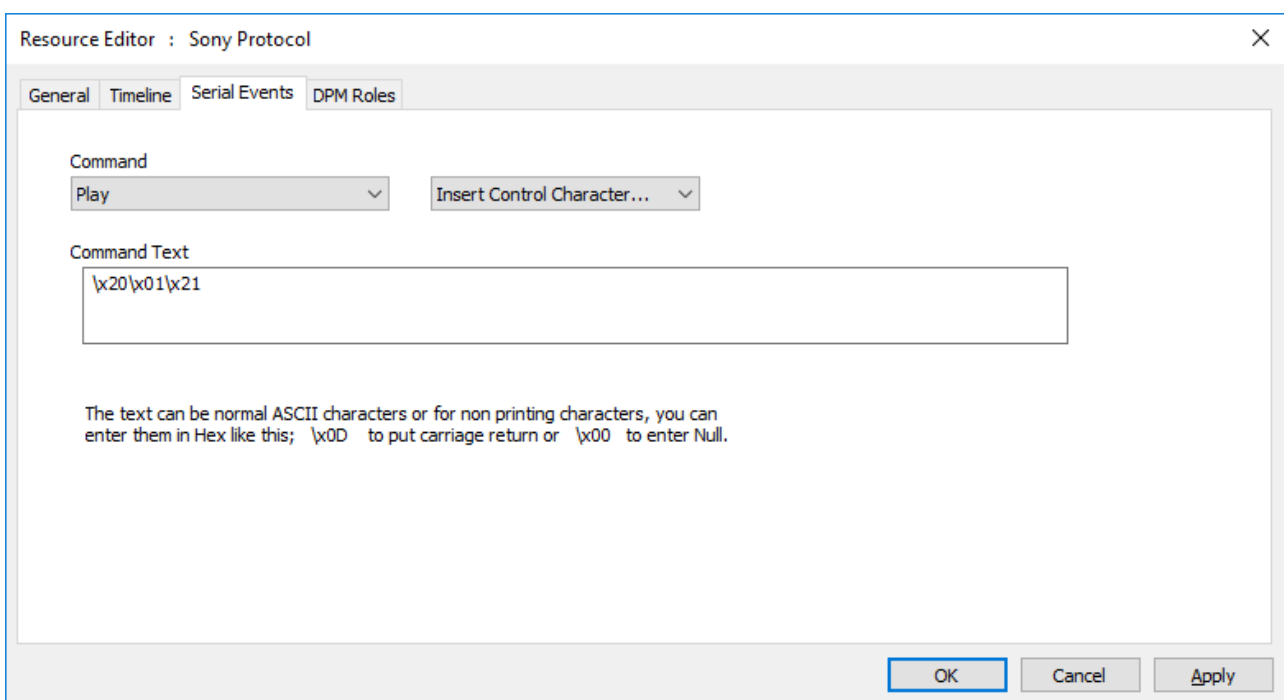

The text in the Command Text box is what is sent out the serial port. You can enter ASCII characters directly, or for non-printing characters for example, use the hex notation of \xEB to send character 235. You can edit this string directly and the new string will be saved with the file, but the Resource Pool version of this serial Event device is not altered.

If you create a file named 'External Control.7SE' in the SERIALEVENTS folder, the contents of this will be available when adding an external control event to the timeline. This allows standard external control commands to be available. The format of this file is the same as other serial event 7SE files.

➤ See [Appendix A: External Control](#) <sup>439</sup>

## RS232 or Telnet Serial Events

A serial event can be output to any IP address and port instead of an RS232 COM port by including the following XML snippet (shown in red, note, this is case sensitive) in the serial event file:

```
<RESOURCENAME>Telnet</RESOURCENAME>  
<TELNET>  
  <Active>1</Active>  
  <IPAddress>192.168.2.8</IPAddress>  
  <Port>25</Port>  
</TELNET>  
<SERIALEVENTS>
```

You can type in any default IP Address and port.

When the Telnet section is found in a serial event file, it is no longer available in the COM port list (*Configure > Preferences > Communications*), and when you edit the properties, the IP Address and port are shown on the Timeline tab. The serial event is sent out as a UDP packet to the specified address.

### Repeat Frames

Enable Repeat and this value sets the frame interval between repeated instances of this serial event.

### Repeat Count

Enable Repeat and this value sets the number of times this event will be repeated (1 = repeat once more on timeline).

### Add Frame

Enable this to append the current frame to any string output by this serial event

## Colour LUTs

---

Colour LUTs are tables of numbers that apply colour transformations to images. These can be either a quick way of modifying colour temperature, saturation, vibrance etc., or a more complex transformation to a vintage look and feel, or that of a well-known movie. Rather than reprocessing the media, the LUT can be used to modify the media at the point of projection, in Delta.

Colour LUTs have three functions: to calibrate colour, to change the colour space, or to add artistic effect.

LUT files (.CUBE) must be placed in the C:\Colour folder or as subfolders. As other resources, drag a Colour LUT into the required resource layer (or background layer), where it becomes effective for movies or images in that layer, when in scope.

As with all timeline resources, right-click a colour LUT on the timeline to bring up the Resource Editor. Here you see and can rename its External Control name, be precise about its position and edit its timeline options.

## Layers and Render Order

Note that on a background layer, a LUT is applied to a particular channel. This can be useful in balancing out colour between projectors, and a colour calibration application to derive a precise 3D LUT could be used:

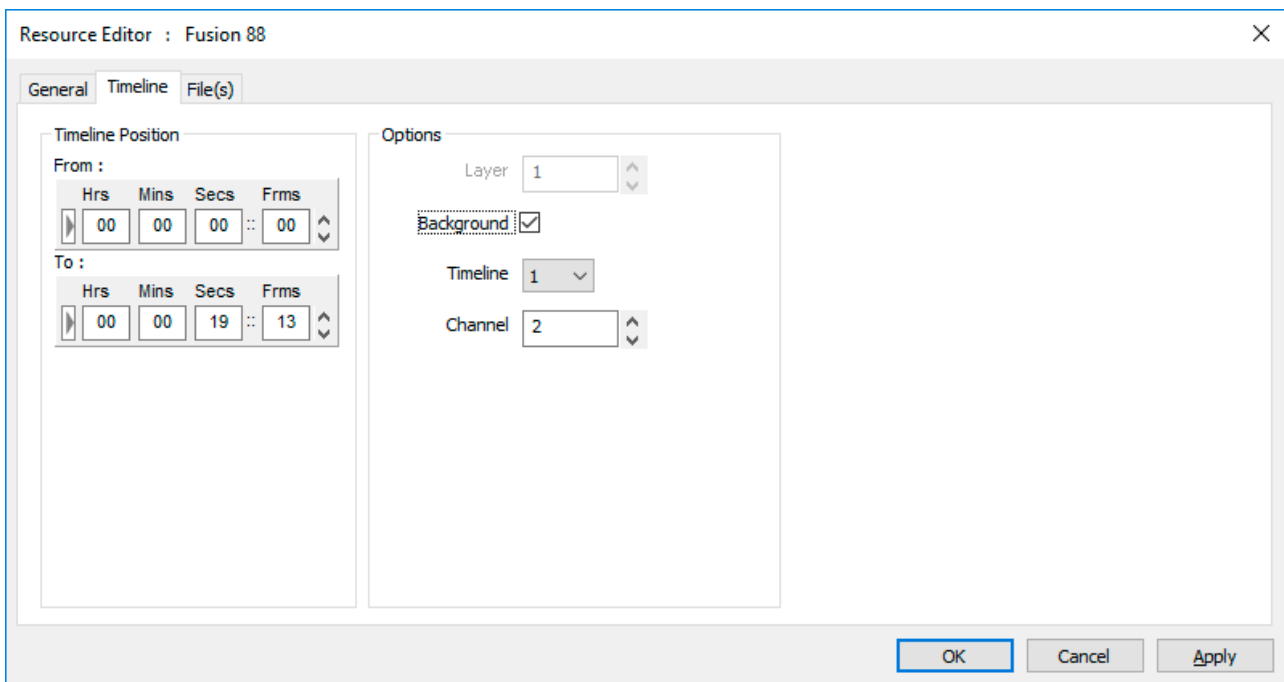

The two-channel playback image below shows the application of a colour LUT (left channel) compared with the untransformed colour on the right channel:



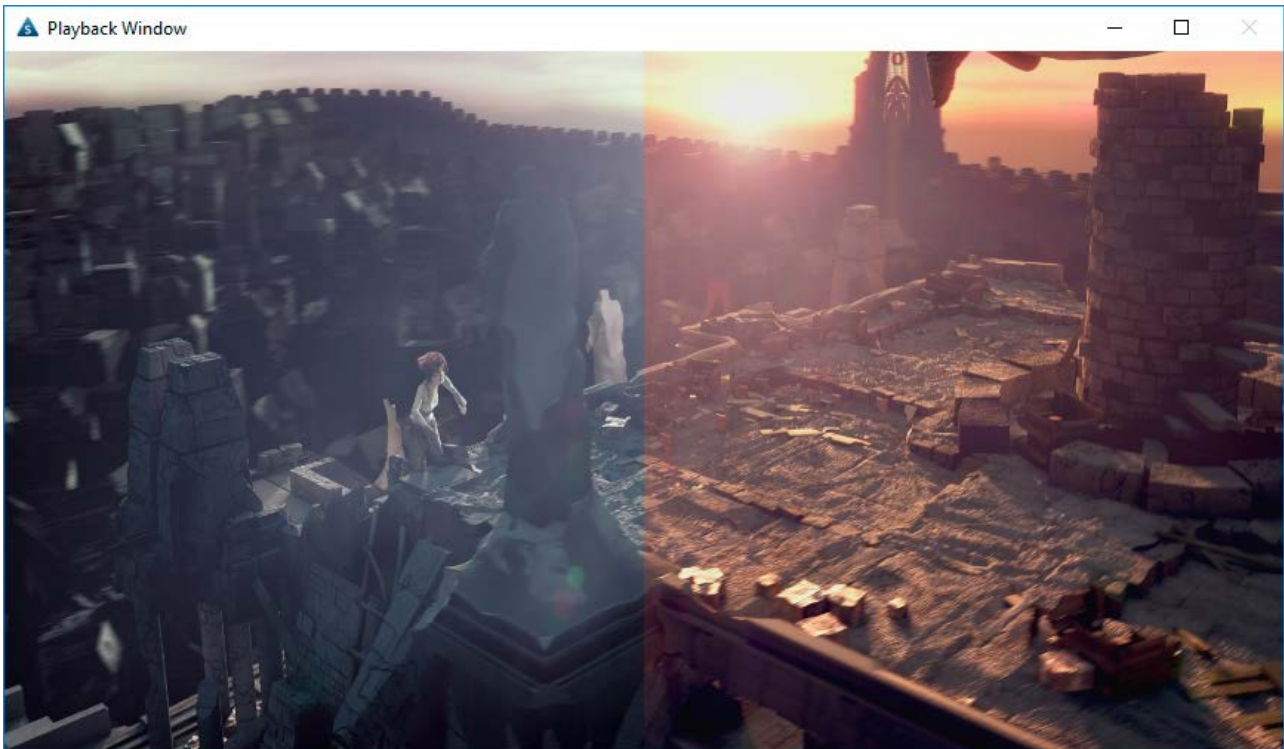

To apply a colour LUT to the entire canvas in a timeline background layer, assign copies of the LUT to each channel.

As with all timeline resources, the render order is relevant. LUTs are applied in this order, and their effect is additive: Layer 3DLUT > Layer 1D LUT > Channel 3DLUT > Channel 1D LUT.

### Additional technical notes on colour LUTs

LUTs can be 1-dimensional or 3-dimensional. 1D LUTs are simpler and map each RGB channel separately. 3D LUTs use the three colours as axes of a cube (hence the file type).

Delta uses the standard .CUBE file format.

## Splines

On the Splines editing page, you can select any of the pre-defined shapes from the Resource Pool and add them to the timeline as with any other resource. Splines can be applied to any layers, including the background layer.

Splines can be edited in the [Display Configuration menu > Splines](#)<sup>155</sup>, where they can be saved as Pool Resources.

Double click a Spline resource to edit its properties on the timeline.

## Spline Timing

By default, the spline is set to **Equal Timed mode**, where the total time of the spline is split equally among the number of nodes in the spline, which means the speed between nodes is dependent on the onscreen distance between the nodes.

In **Node Timed mode**, you can edit each node and change its time along the node, giving fine control over speed.

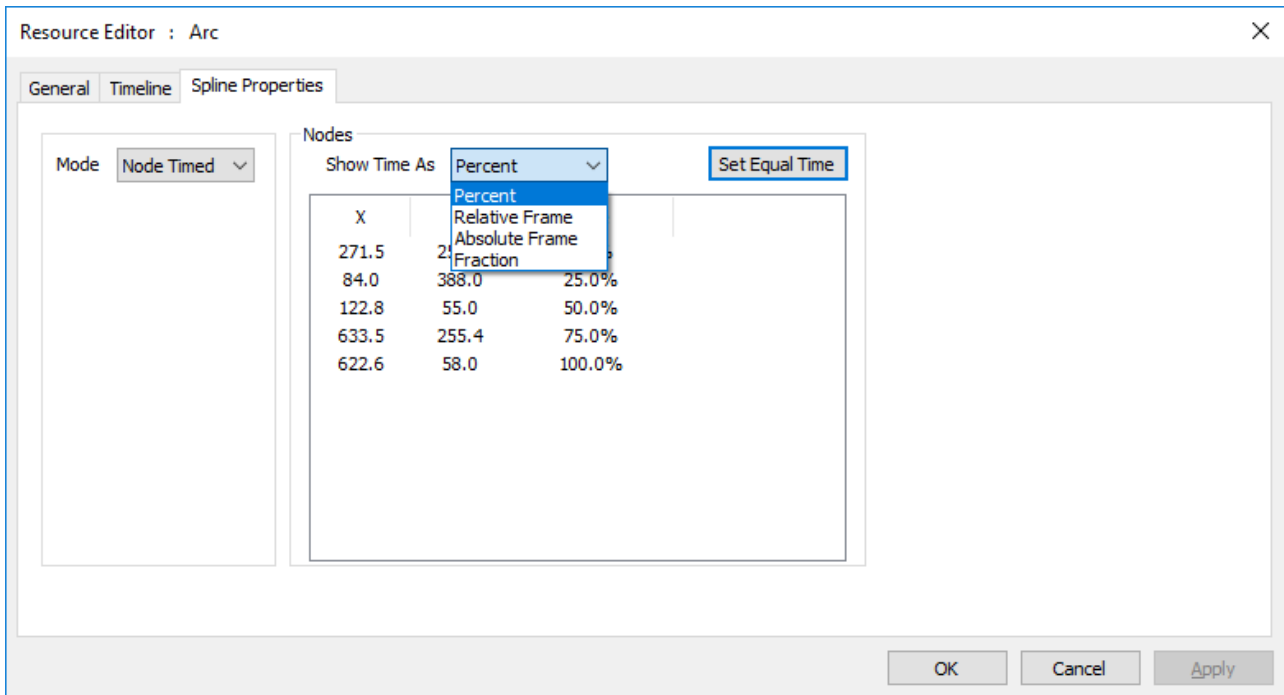

The two modes are shown differently on the timeline, with Node Timed spline showing the time of each node as a tick mark descending from the spline box, and Equal Timed spline showing the tick mark within the spline body:

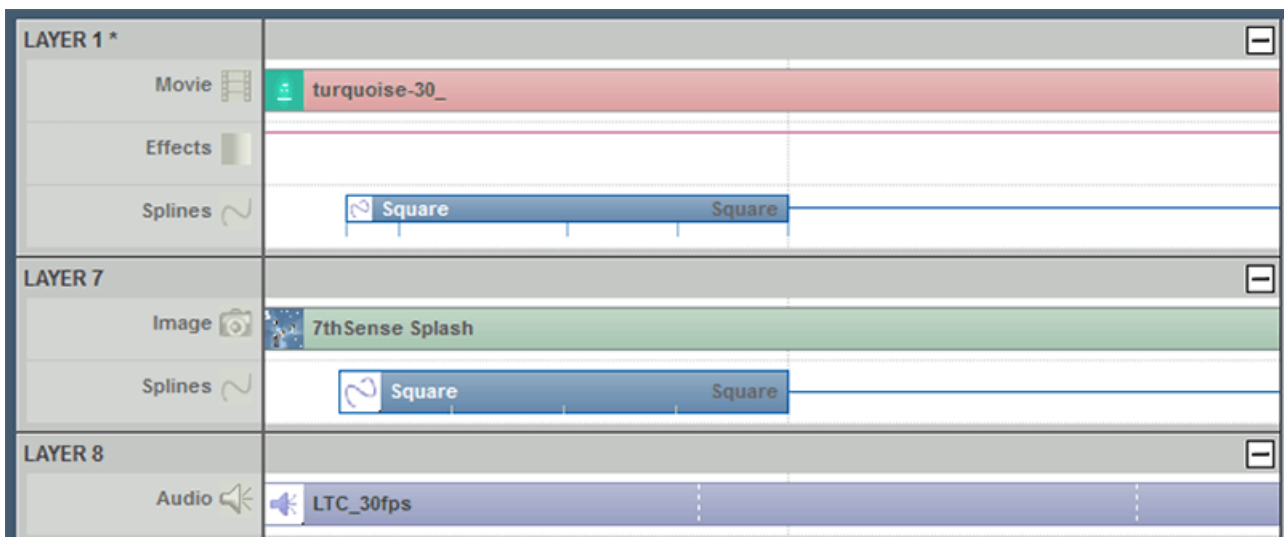

## Node-Timed Splines

To change modes and edit the node time, right click, select Properties and then Spline Properties.

To edit the node times, select Node Timed from the drop down, then double click one of the nodes to edit the node location onscreen or the time of that node. Note that a node cannot be set later than the next node or earlier than the previous node and that the first and last nodes are fixed at 0% and 100%.

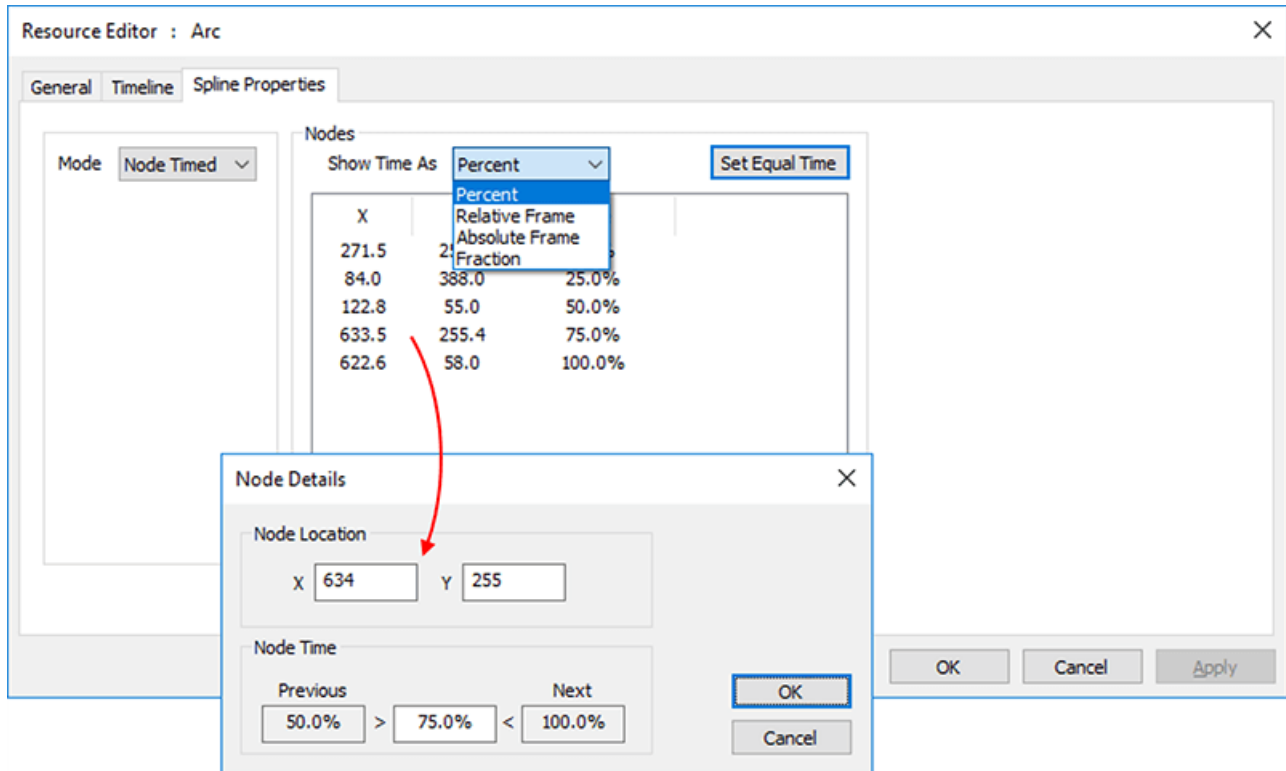

## Art-Net and DMX

Delta can output an Art-Net data stream (which can then be converted to DMX using Ethernet-DMX convertors) and also take Art-Net inputs which can carry out any of the external control commands within Delta.

Shown below is a timeline with various input and output Art-Net resources:

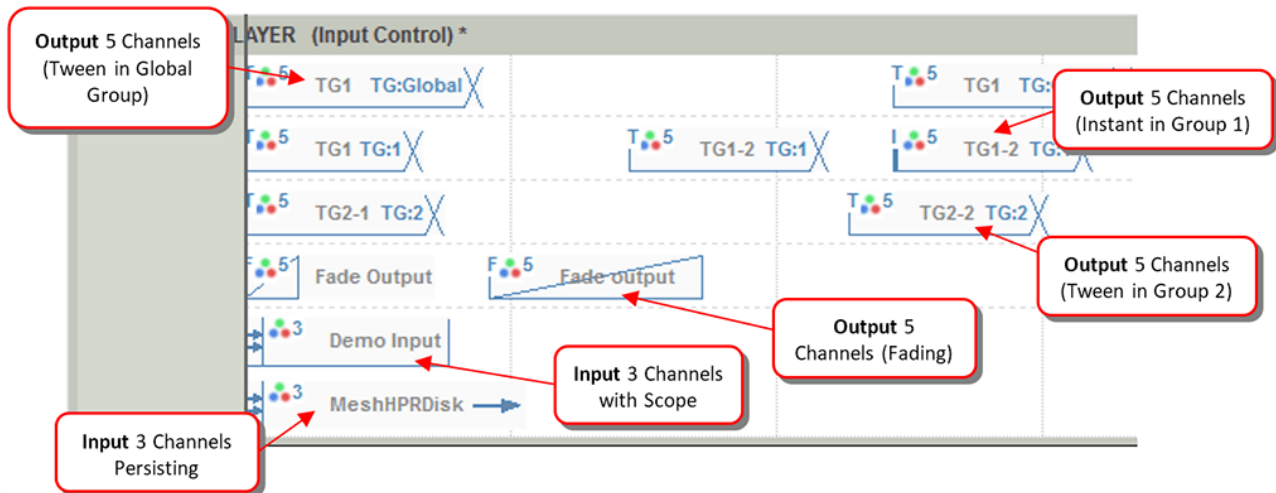

**Create** Art-Net I/O Resources here: DeltaGUI Menu: *View > ArtNet and DMX Editor*

**Edit** Timeline resources directly with the [Art-Net Resource Editor](#) <sup>(340)</sup>

## Output Art-Net

Once output is enabled (see *Config > Preferences > ArtNet and DMX*), Delta is broadcasting an Art-Net datastream to the network address(es) specified. With no Art-Net resources on the timeline, all output channels will be set to 0.

## Creating Art-Net output resources

Output Art-Net resources can be created using the Editor (DeltaGUI Menu: *View > ArtNet and DMX Editor*), which is shown below with a typical 5-channel DMX controlled Floodlight device.

### Base Address

This is the first active channel this device will have, so if set to 15 and choose the first output channel as DMX Channel 1, this will actually be 15.

### Mode > Fade

In Fade Mode, the output values will change from the previous value to the preset values over this fade time, so by the end of the fade time, the values in that resource are active. You can set the Fade Time in seconds in this mode.

### Mode > Instant

In Instant Mode, the output values will change instantly from the previous value to the preset values, so at the start of the resource, the values in that resource are active.

### Mode > Tween

In Tween Mode, the output values will change to the values in the resource by the start of the

resource, so the values smoothly change from the previous resource to this resource's values by the start of the resource.

In Instant or Tween Mode, the Tween Group is active (TG 0 – TG 65535). To separate different instant or tween resources, you can put them in different Tween Groups, so that a resource with TG12 will only tween from a previous resource also in TG12. A special case is Tween Group 0 (Global) which will tween from any previous tweening resource, regardless of its tween group and also any tweening resource ahead of the Tween Group 0 resource will tween from its values.

## Mixing different Art-Net output resources

For the same Art-Net channels, you cannot mix Tween mode resources and Fade types (this will lead to indeterminate values), but Tween and Instant can be mixed. This means that fade type output resources should be kept on separate channels to tween or instant resources.

**Note:** All Art-Net output resources persist from the start of the resource, there is no end frame.

## Art-Net and DMX Editor showing Output resource

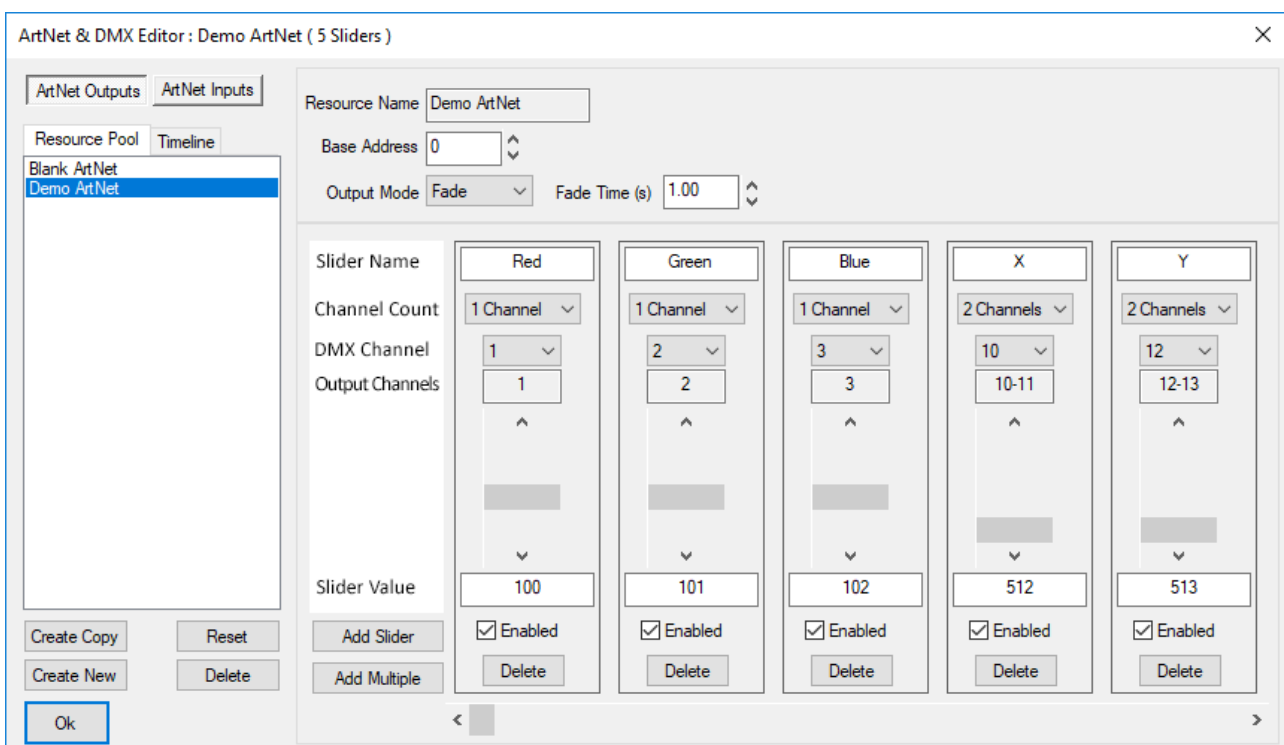

The device shown above has 5 'Sliders', where each one is assigned parameters:

### Slider Name

Memorable name for this channel

**Channel Count**

You can choose 1, 2 or 4 channels for this slider.

For 1 channel used, the range is 0 – 255

For 2 channels, 2 adjacent channels are ganged for a range of 0 – 65535

For 4 channels, 4 adjacent channels are ganged for a range of 0 – 4294967295

**Note** that if you choose higher channel count, adjacent DMX channels are used, so for example if Slider 1 is Channels 1 and 2, Slider 2 should start at Channel 3 minimum, otherwise you have overlapping channels with unpredictable results.

**DMX Channel**

The only (channel count of 1) or base (channel counts of 2 or 4) channel for this slider

**Output Channels**

This is an addition of Base Address and the base DMX Channel

**Slider / Slider Value**

You can use the slider to set the output value, or for more accuracy, type in the value

**Enabled**

Check this box to use this slider

**Delete (Slider)**

Press this to delete the slider

**Fade/Instant/Tween**

Choose the mode of this resource (see descriptions above):

**Fade:** Select the Fade time in seconds

**Instant:** Select the Tween Group

**Tween:** Select the Tween Group

**Input Art-Net**

This can be enabled separately from Art-Net output in the [Config > Preferences > ArtNet and DMX](#)<sup>123</sup> page. To show Input resources in the Art-Net and DMX Editor, press the Show Inputs button, then you can select the pool or timeline input Art-Net resource from the list.

## Creating Art-Net input resources

Shown below is an example 'mediacolour' input device where the device listens to channels 1,2 and 3, and if any changes in values within those channels are detected, sends an internal MEDIACOLOR command constructed from the Control Message and Slider Names as below.

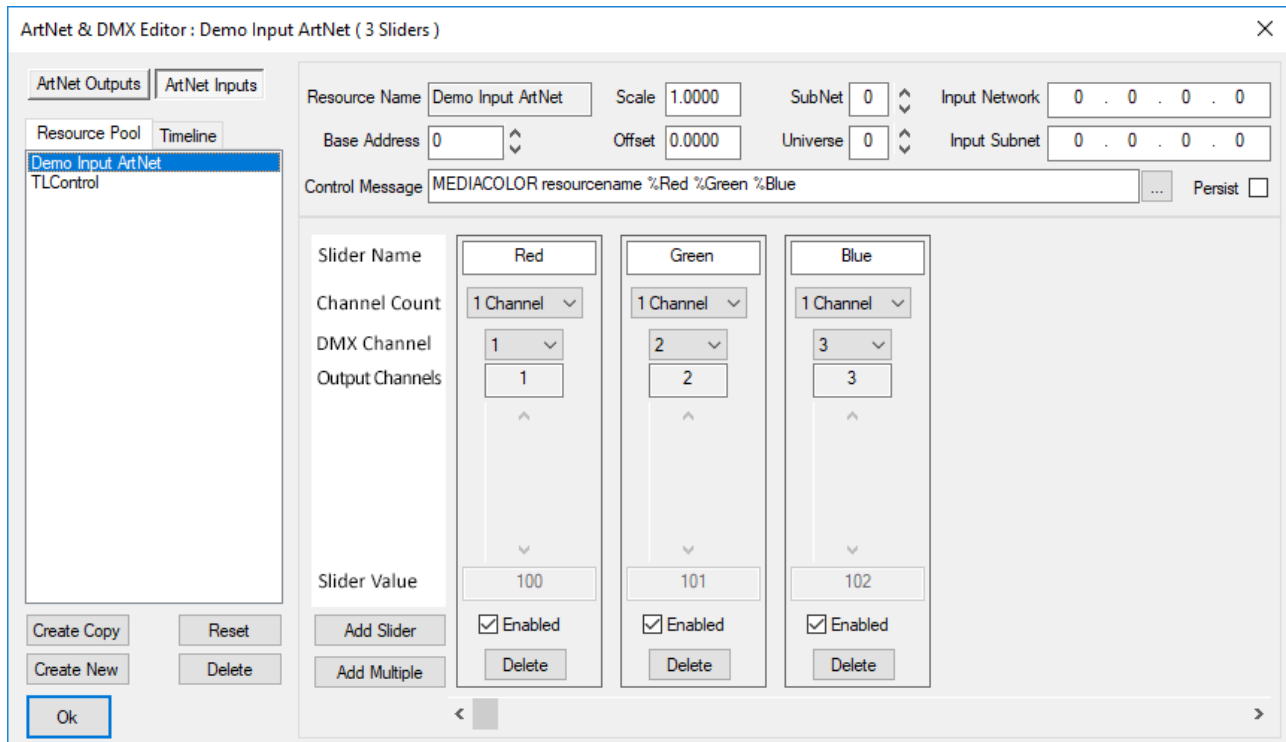

In the next example, the Slider Names are X and Y, and the Control Message is MEDIAMOVE resourcename %X %Y, so in this case the %X string in the message is replaced with the value of the X Slider, %Y with the value of the Y Slider, so that that actual message sent internally is:

```
MEDIAMOVE resourcename 100 101
```

Which will change any visual resource with a name of 'resourcename' to 100 in X and 101 in Y.

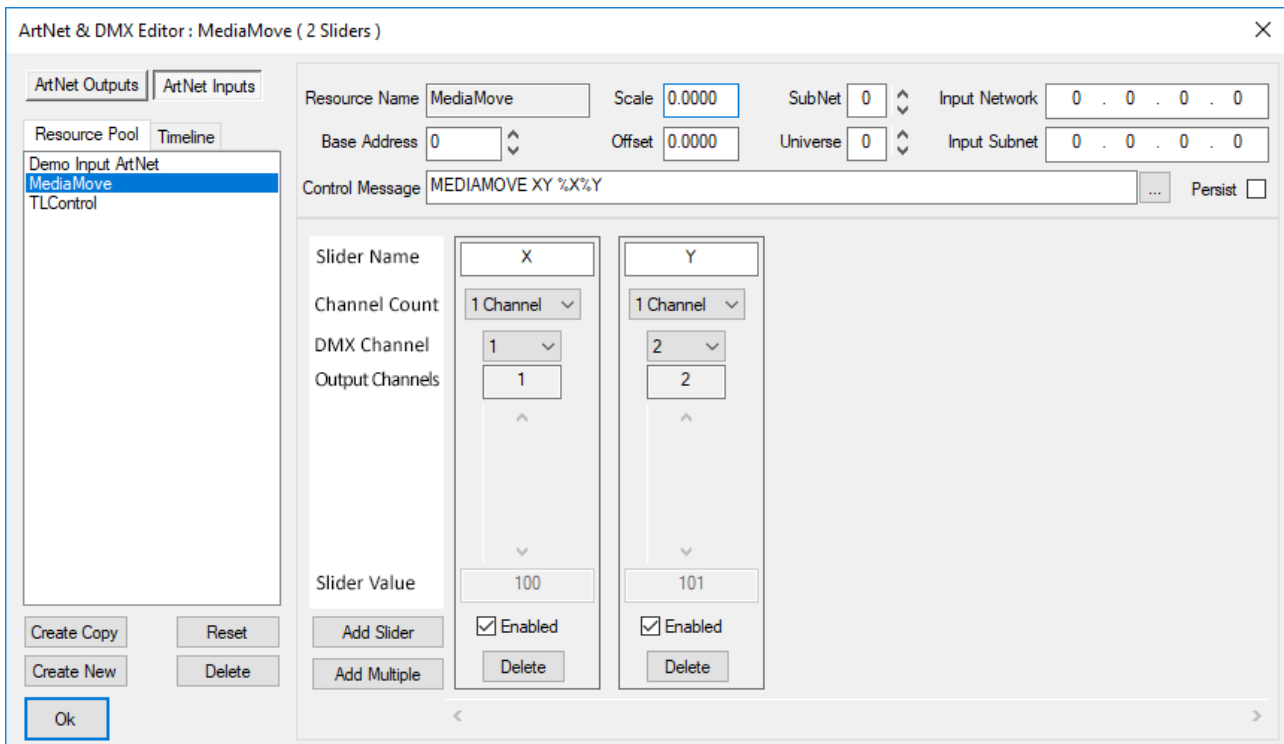

**Note** that if the Control Message does not find the %Variable name in the Sliders, it will send that string directly, which may cause the command to fail.

### SubNet

0 – 15, these are separate Art-Net SubNets which can be listened to

### Universe

0 – 15, these are separate Art-Net Universes which can be listened to

### Persist

If enabled, this Input device will listen from the first frame on the timeline onwards (no end), if disabled, it will only listen if the timeline current frame is within the scope of this resource.

## More Examples: Marker Selections

An input Art-Net resource is required to go to a marker depending on the value of Art-Net channel 1, so you add an Input Art-Net resource to the timeline at frame 0, set it to Persist, then have one slider with a name of 'Name', set to channel 1 and the control message is:

GOTOMARKER %Name

Now create markers on the timeline with Marker Name of '1' and '2' and place them on the timeline where you need, then when channel 1's value changes from 0 to 1 to 2, gotomarker commands will be issued of GOTOMARKER 0, GOTOMARKER 1, GOTOMARKER 2 and since the marker exists for 1



and 2, these commands will succeed, where the value of 0 will do nothing, since there is no marker named '0'.

### More Examples: Setting Global Variables

An Input Art-Net resource is required to set 3 global variables for use by a sequence, so you add an Input Art-Net resource to the timeline at frame 0, set it to Persist, then have three sliders with names of 'Ch1', 'Ch2' and 'Ch3' (set to channels 1, 2 and 3) with the control message:

```
globalvarset cmd=realtime $ch1=%Ch1 $ch2=%Ch2 $ch3=%Ch3
```

When any Art-Net values in channels 1, 2 or 3 change, the command is issued like this for values of 3, 45 and 88:

```
globalvarset cmd=realtime $ch1=3 $ch2=45 $ch3=88
```

This in turn sets (or creates and sets) \$ch1, \$ch2 and \$ch3 variables to the values shown, which can be used within any sequence, for example to control media colour, position etc. The benefit of this is that the values can be manipulated in the sequence, for example offsetting or scaling them as required based on other inputs or variables.

The cmd=realtime is used to speed up this command, disabling logging so that for fast movement of channel values, the command is actioned as fast as possible.

### More Examples: External Control LCTimeline

This Logic Control command is for real-time conditional actions based on an integer value. Example: play="75,50,100" will cause the timeline to play if 75 is between 50 and 100. This is most useful for Art-Net commands where 75 would be replaced with the value of an Art-Net input.

In the following example, actions have been assigned to a series of 7 named Art-Net/DMX faders (named variables %fader1, %fader2 etc.). The full LCTimeline control is:

```
lctimeline rewind="%fader1,0,20" stop="%fader1,40,120" cue="%fader1,160,220" play="%
fader1,240,255" tl=1\r\n
lctimeline rewind="%fader2,0,20" stop="%fader2,40,120" cue="%fader2,160,220" play="%
fader2,240,255" tl=2\r\n
lctimeline rewind="%fader3,0,20" stop="%fader3,40,120" cue="%fader3,160,220" play="%
fader3,240,255" tl=3\r\n
lctimeline rewind="%fader4,0,20" stop="%fader4,40,120" cue="%fader4,160,220" play="%
fader4,240,255" tl=4\r\n
lctimeline rewind="%fader5,0,20" stop="%fader5,40,120" cue="%fader5,160,220" play="%
fader5,240,255" tl=5\r\n
lctimeline rewind="%fader6,0,20" stop="%fader6,40,120" cue="%fader6,160,220" play="%
fader6,240,255" tl=6\r\n
```

```
lctimeline rewind="%fader7,0,20" stop="%fader7,40,120" cue="%fader7,160,220" play="%fader7,240,255" tl=7
```

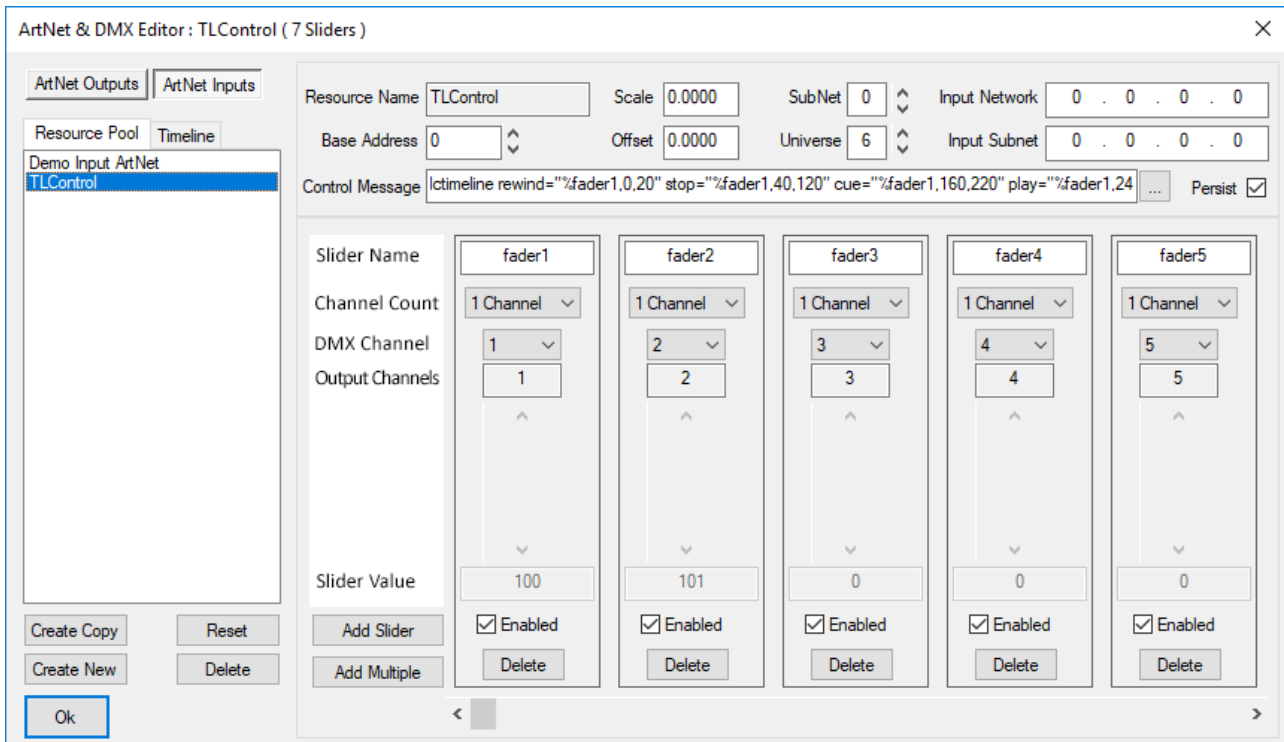

## Pool and Timeline Resources

There are 2 built-in Output Art-Net resources ('Blank' has no channels, and 'Demo ArtNet' has 5 active channels) and 1 built-in Input Art-Net resource ('Demo Input ArtNet' has 3 input channels connected to a Mediacolor external control command).

When you edit a Built-in Pool resource, changes are discarded on server exit, but if you create a new Output or Input Pool resource, this is saved into the C:\ArtNet folder as a small XML device file and any changes you make are reflected to that device on disk immediately.

When you edit a Timeline resource, changes are instant and will be saved into the normal show XML.

## Common Controls to Input and Output

### Create Copy

Copy the current selected resource to a new one.

### Reset

Remove all sliders from the selected resource.

**Create New**

Create a new blank device.

**Add Slider**

Add one slider (will be added after the last active channel).

**Add Multiple**

Add multiple sliders at a set base channel.

**Arrow Buttons**

Navigate to the next, previous, first or last slider.

**Delete (Resource)**

Delete the selected resource on the timeline or resource pool. Note that you cannot delete the built-in pool resources (Demo ArtNet or Blank ArtNet) and that deleting the others permanently removes them from the server (from the C:\ArtNet folder).

**Note** that editing an Output Art-Net resource from the timeline (using the normal resource editor) gives a cut down version of this dialog where you can change most parameters apart from Channel, Channel Count and you cannot add or remove sliders from this dialog.

## Playlist / AV Assembly

---

These are a [Container](#)<sup>49</sup> type resource.

A playlist is a resource which can contain other resources (known as child resources), which can be movies, images, audio, text and capture types. These continually play in sequence, independent of the timeline playing or not, so the server does not have to be playing for the movies, capture etc. inside the playlist, to be playing.

[AV \(audio-visual\) Assemblies](#)<sup>393</sup>, are Containers designed to hold one movie and N audio resources for that movie, so that they are kept together as a group. For example, a single movie and 6 audio resources can be placed in to the AV Assembly, then this resource can be moved around the timeline as a grouped set of resources.

Playlists are simple ways to create a running show – add a playlist to the timeline, then drag and drop resources into the playlist resource from either the timeline or the resource pool. If the playhead is anywhere in scope of the playlist, they will play in sequence, looping from the end item to the start automatically.

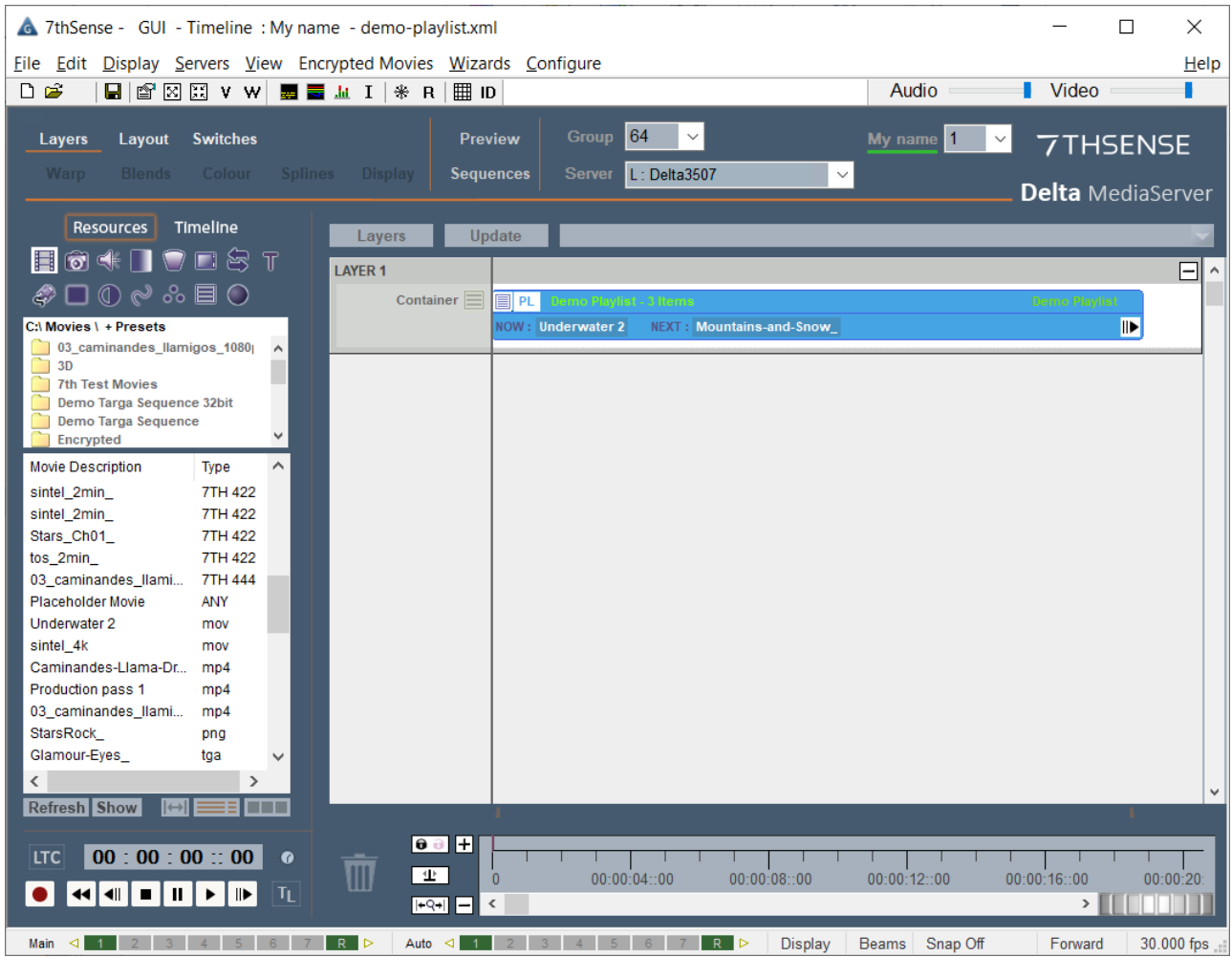

Once a playlist has been populated, you can edit it by right clicking and choosing Edit Playlist Contents, which shows the dialog below for the selected playlist.

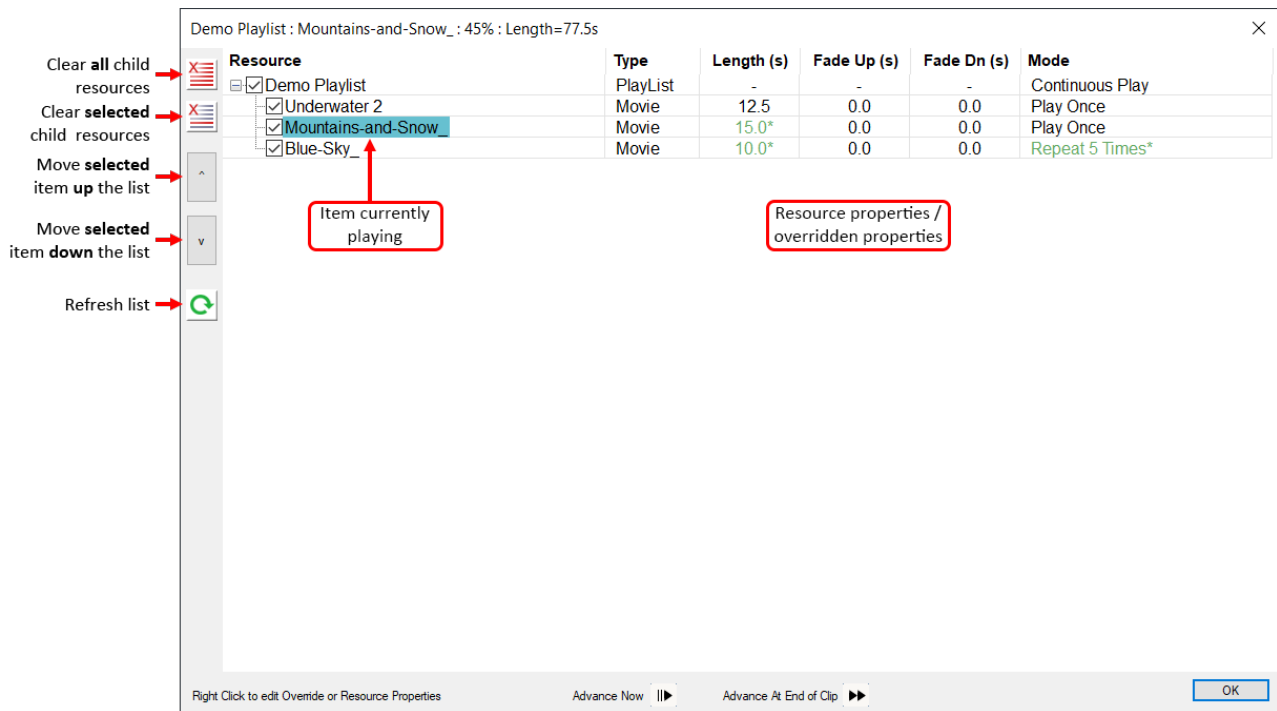

In the dialog above, 4 movies are shown, which will continually play from top to bottom – you can move items up or down the list using the arrow buttons shown, select and delete one child resource or empty the playlist using the Clear All button.

The item that is currently playing is shown in a different colour on the left whilst on the right, the length of the movie, fade up and down time and play mode is shown. By default, each child resource is added with a default length:

Movies	Native non-looped length of the movie
Image	10s
Audio	Native non-looped length of the audio
Capture	10s
Text	10s

## General notes

- You can remove items from a playlist by right clicking on it and choose **Detach from parent**.
- Multiple playlists can be in scope at the same time (subject to the performance limits of the server) so that you can spatially separate them using playlist or resource overrides on the screen location.

- You can save a preset of a playlist or AV Assembly which will then appear as a resource in the Resource Pool – when you drag this preset onto the timeline, it will contain all the saved child resources as well.
- When you drag a playlist or AV Assembly to the wastebasket or delete by some other means, all child resources are also deleted from the timeline
- The Current and Next items in a playlist are shown on the resource, with progress bar showing how far through the current item is.

### Individual Child Resource Overrides

You can edit each resource and change this length by double clicking or right clicking to choose **General Override Properties** for that child resource. In the image below, the ‘Mountains and Snow’ movie is shown overridden to 12s instead of its native 15s length. In the main playlist editor, this is shown in green as 12s\* to indicate it is overridden from native properties.

**Note** that audio and video will be seamlessly looped if necessary to meet the set duration.

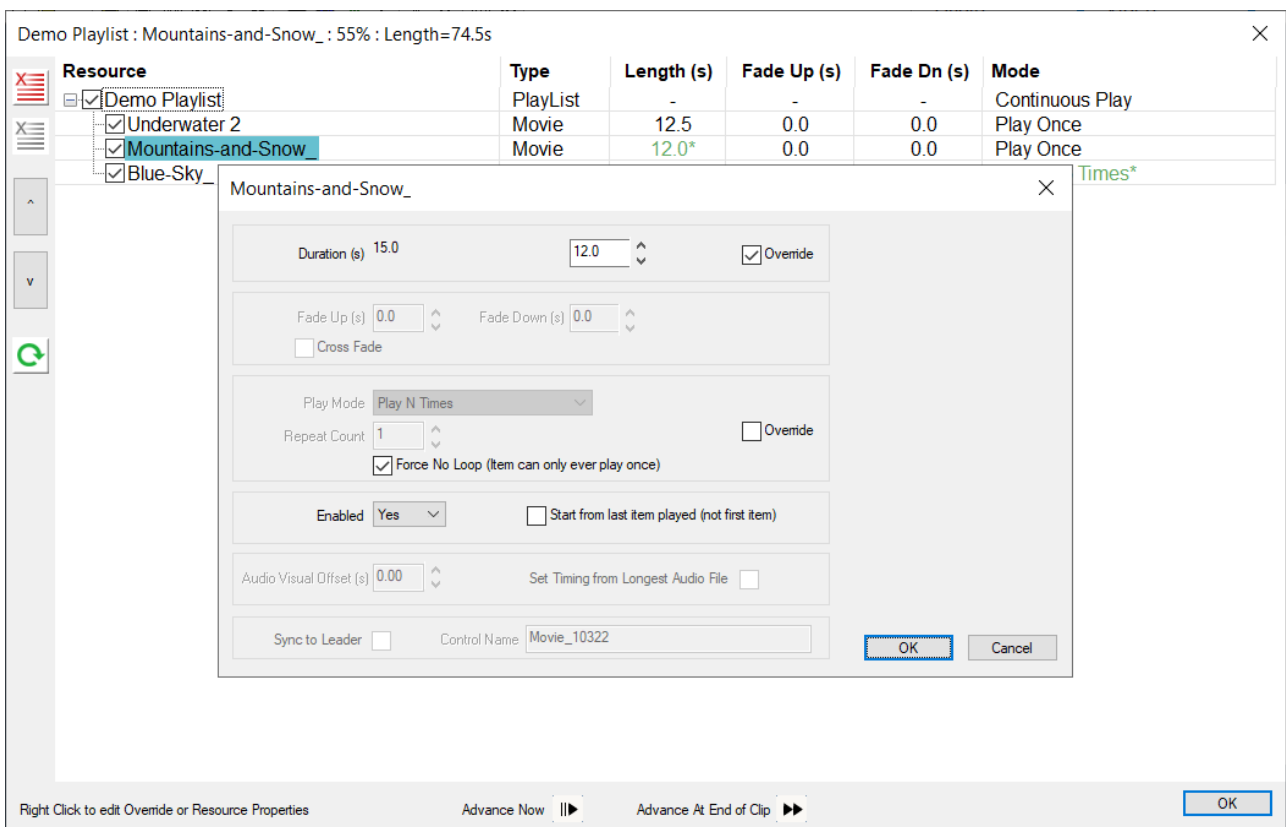

Also on this dialog, you can override the play mode from its default of playing once before moving onto the next item. Other modes available are:

#### Play N Times

Choose to play a set number of times before moving on

**Repeat Until Triggered**

Continually loop this child until a trigger is received from external control (PLAYLISTNEXT with or without Immediate) or using the Advance or Advance At End of Clip buttons. This will also transition with any set fades.

**Force No Loop**

Play this item once only and then show black until triggered

Other items on that dialog are:

**Start from last item played**

When the playhead plays into the playlist, choose to always play the first item or the last one played by that playlist.

**Audio Visual Offset (AV Assembly only)**

Offset the audio from the video in an AV Assembly (see below) in seconds, this can be negative as well.

**Set Timing from Longest Audio File (AV Assembly)**

For an AV Assembly only, choose the length of the AV Assembly from the longest audio resource instead of the default movie length.

**Sync to Leader / Control Name**

Follower only, in order to sync up a playlist on Leader and Follower servers, with this set, will trigger the same items on both servers at the same time. This requires the external control name of the Follower playlist to be the same as that on the Leader. If the items are not the same, so some are missing on the Follower compared to the Leader, black will be shown on the Follower.

## Global Playlist Resource Overrides

It is also possible to override all child resources by right clicking on the **Playlist** itself and choosing **General Override Properties**.

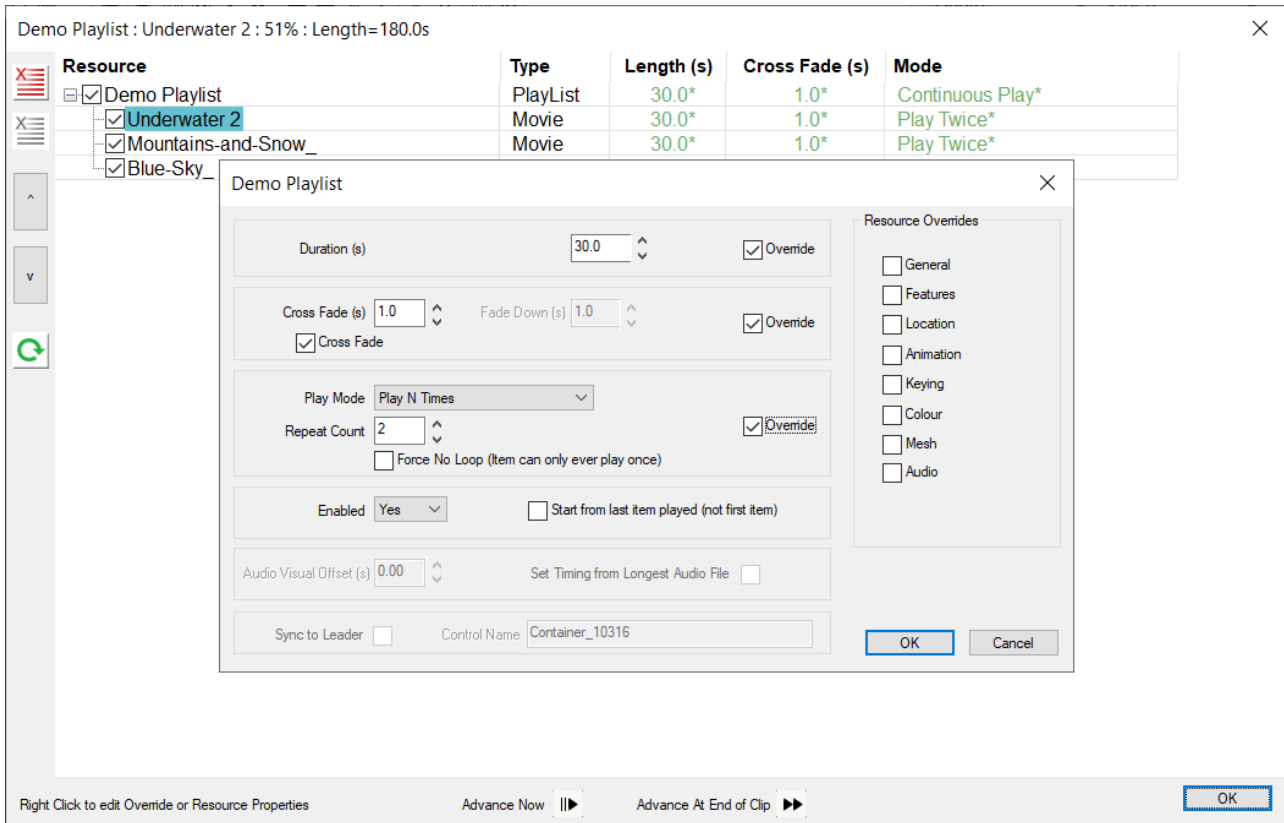

In the image above, the Playlist item overrides are shown, with a 30 s duration and cross fade of 1 s. All child resources are shown green with 30 s\* to show they are overridden.

**Note** that the 12s override previously set on the single child resource is overridden by the global playlist parent resource to 30s.

Other controls specific to Playlist level overrides:

### Fade Up / Fade Down

Set the time in seconds for the child resources to fade up and down

### Cross Fade

Instead of fade up/down to black, start playing the next item while the existing one is playing and fade the current one down, achieving a cross fade between the items.

**Note** that if the two adjacent resources are movies, you are requesting double the bandwidth from the server during the crossfade time, which may impact performance.

## More Detail

In addition to overriding duration etc., on the dialog above, you can override many other things such as screen location, colour and more. To set these override values, right click on the Playlist item (from timeline or the playlist editor) and choose **Resource Override Properties**. This shows the common



resource editing dialog pages as shown below, but with the addition of an Override Children checkbox in the lower left corner of each page.

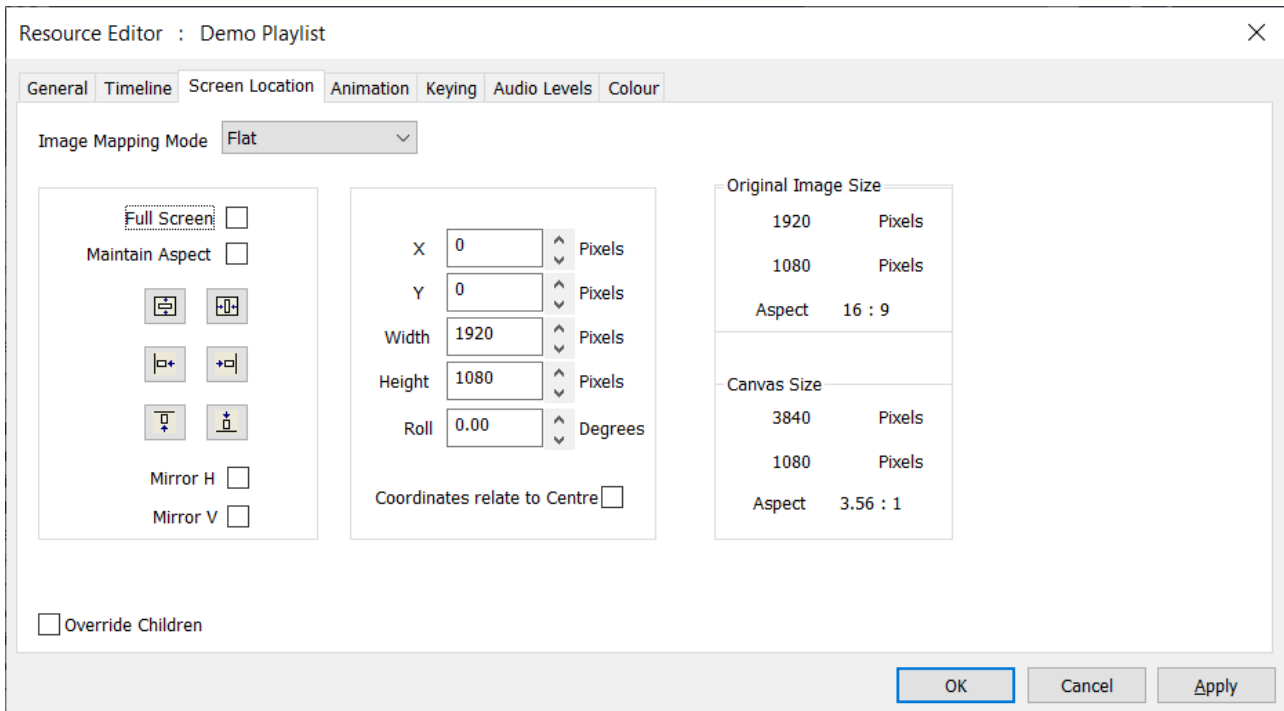

In the example shown, the playlist screen location is set to X,Y 0,0 and 1920 × 1200 in size.

With the Override Children checkbox selected, all visual child resources will be forced to this size. All Override Children checkboxes are also shown on the right side of the Edit Overrides dialog for a quick way to enable them.

## Audio Visual Assemblies

Also known as AV Assemblies, these Containers are designed to hold one movie and N audio resources for that movie, so that they are kept together as a group. For example, a single movie and 6 audio resources can be placed in to the AV Assembly, then this resource can be moved around the timeline as a grouped set of resources.

AV Assemblies can contain any single resource from the following list (Movie, Image, Text, Capture) as well as a number of audio resources – you cannot drag in a second visual resource from that list.

You can construct an AV Assembly by dragging a 'Demo AV Assembly' which is empty onto the timeline, then dragging audio and visual resources into it. You can edit it as before by right click and choose AV Assembly Contents as shown below:

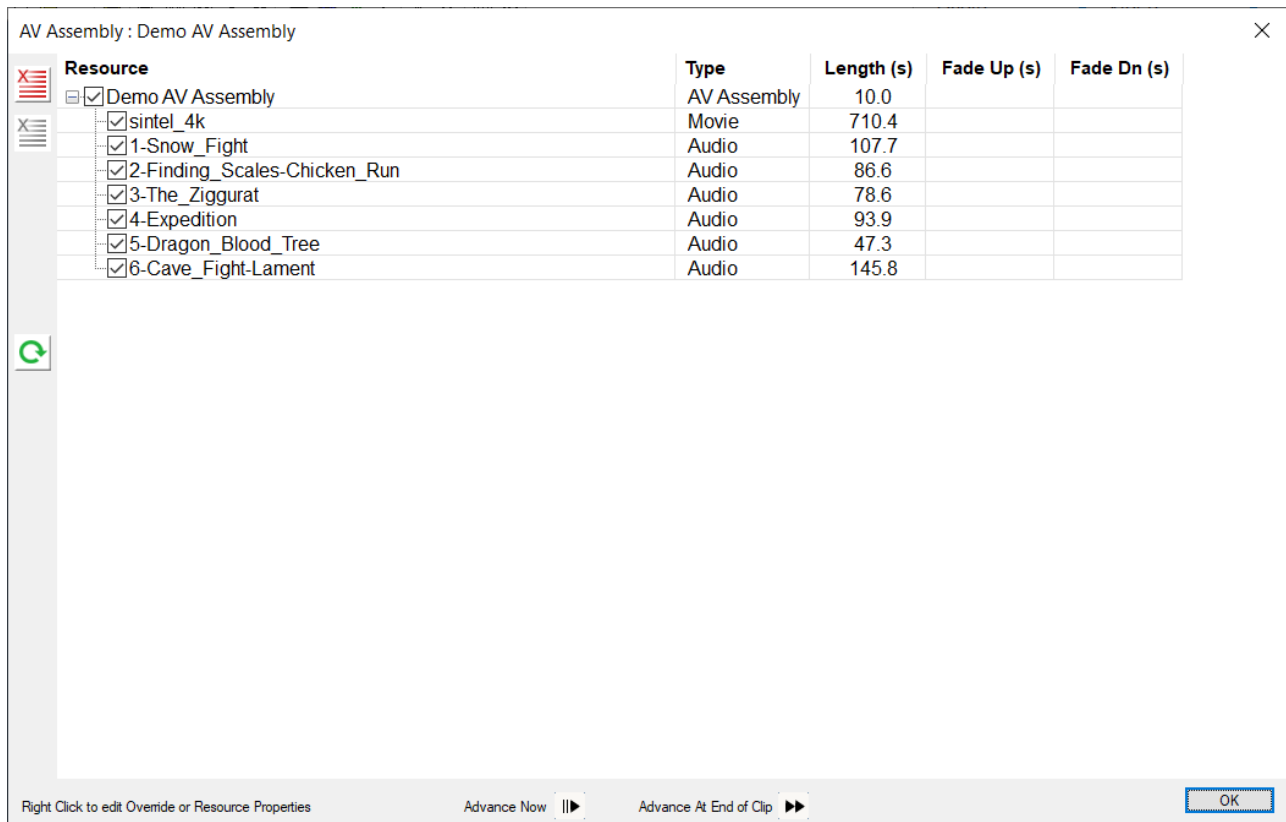

You can override individual resources as before (right click on a child resource, choose General Override Properties) or override all child resources (right click on the Demo AV Assembly and choose General Override Properties). You can also override resource properties of all child resources as before (right click on the Demo AV Assembly and choose Resource Properties, then choose which pages to override).

To move an AV Assembly into a playlist, move it from a different layer than the playlist.

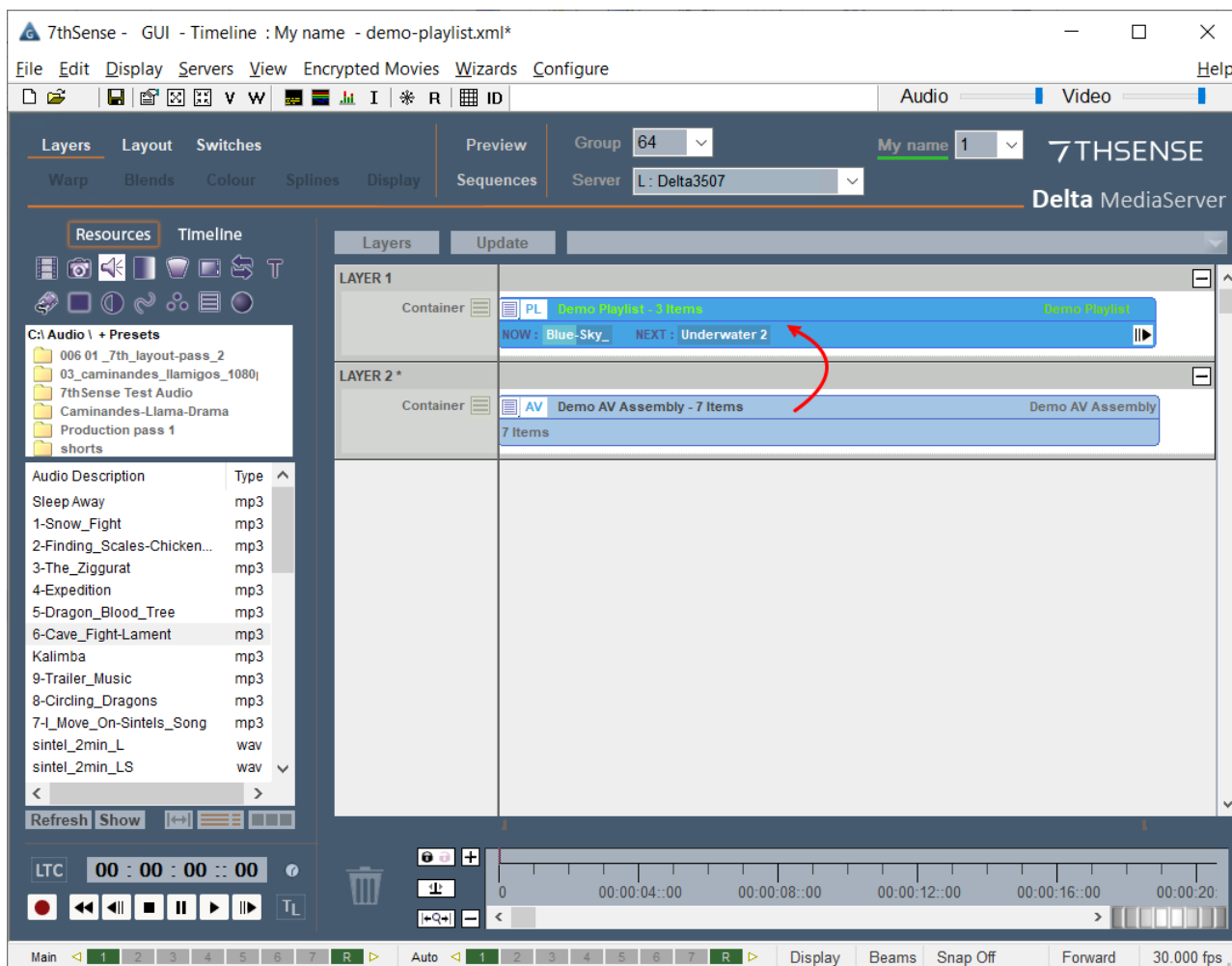

AV Assemblies, once created, can be dragged into a playlist as shown below:

Demo Playlist : Underwater 2 : 36% : Length=784.9s

Resource	Type	Length (s)	Fade Up (s)	Fade Dn (s)	Mode
<input checked="" type="checkbox"/> Demo Playlist	PlayList	-	-	-	Continuous Play
<input checked="" type="checkbox"/> Underwater 2	Movie	12.5	0.0	0.0	Play Once
<input checked="" type="checkbox"/> Mountains-and-Snow_	Movie	12.0*	0.0	0.0	Play Once
<input checked="" type="checkbox"/> Blue-Sky_	Movie	10.0*	0.0	0.0	Repeat 5 Times*
<input checked="" type="checkbox"/> Demo AV Assembly	AV Asse...	10.0	0.0	0.0	Play Once
<input checked="" type="checkbox"/> sintel_4k	Movie	710.4	0.0	0.0	Play Once
<input checked="" type="checkbox"/> 1-Snow_Fight	Audio	107.7	0.0	0.0	Play Once
<input checked="" type="checkbox"/> 2-Finding_Scales-Chicken_Run	Audio	86.6	0.0	0.0	Play Once
<input checked="" type="checkbox"/> 3-The_Ziggurat	Audio	78.6	0.0	0.0	Play Once
<input checked="" type="checkbox"/> 4-Expedition	Audio	93.9	0.0	0.0	Play Once
<input checked="" type="checkbox"/> 5-Dragon_Blood_Tree	Audio	47.3	0.0	0.0	Play Once
<input checked="" type="checkbox"/> 6-Cave_Fight-Lament	Audio	145.8	0.0	0.0	Play Once

Right Click to edit Override or Resource Properties      Advance Now      Advance At End of Clip      OK

In this case, all audio and visual resources within the AV Assembly will be played as a set.

## Timeline Effects

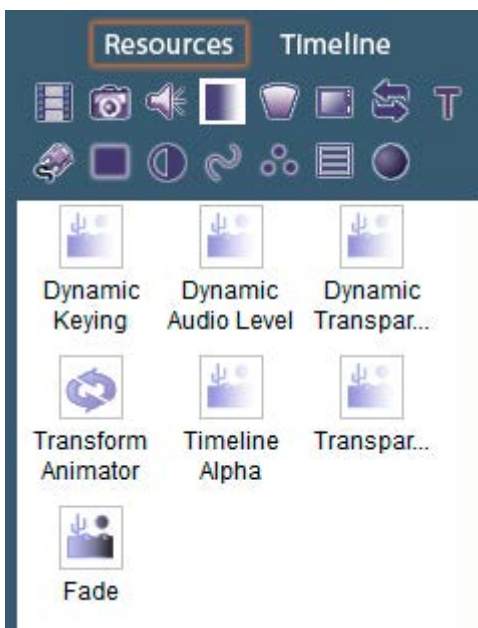

Timeline effects supplied with Delta include dynamic effects that are addressed solely via External Controls, and timeline effects.

**Timeline Alpha:** applies to the *background layer* and fades the current timeline between transparent and opaque.

**Transparency:** applies to the *resource layer* and fades the layer between transparent and opaque.

**Fade:** applies to the *resource layer* and fades the layer between opaque and black.

**Transform Animator:** applies to the resource layer and applies configurable motion affects to resources in that layer (see [Transform Animation](#)<sup>350</sup>).

For effects controls, double-click on the effect in the timeline to open the Resource Editor. Properties of the effect in the Timeline tab are simple and typically include direction, level and duration.

## Shader Effects

---

Shader effects in Delta allow users to create and control the behaviour of the way all media assets are rendered, through Delta Effects, by writing OpenGL fragment and vertex shaders. Effect parameters can be controlled via [External Controls](#)<sup>409</sup>.

### Creating and using effects

Effects can be controlled either through the DeltaGUI or via external control over TCP, UDP or HTTP. This guide demonstrates the process of creating and controlling effects, using the above sample effects created by 7thSense for you to use and experiment with.

Users with Notch Builder or Playback licences and keys, can import and apply DFXDLL files. Files are added to the C:\Effects\Notch folder.

➤ [Using Notch Effects](#)<sup>402</sup>

### Delta Effects File Extensions

There are three file extensions which may be used to create your effects: **.xml** files are used to define the properties for control within a **shader**, whilst **.frag** and **.vert** are the OpenGL shaders used to create the Delta Effects functionality. Each effect may have a frag or vert file, or both.

#### xml files

This simple example demonstrates the basic code structure:

```

1  <?xml version="1.0" encoding="ISO-8859-1"?>
2  <Shader>
3    <Type>Colour</Type>
4    <Name>Per Component Brightness</Name>
5    <Description>Per Component Brightness modification</Description>
6    <PropFloat>
7      <Index>0</Index>
8      <Name>Red brightness</Name>
9      <Description>Modify red brightness level</Description>
10     <Default>1.0</Default>
11     <Minimum>0.0</Minimum>
12     <Maximum>5.0</Maximum>
13   </PropFloat>
14   <PropFloat>
15     <Index>1</Index>
16     <Name>Green brightness</Name>
17     <Description>Modify green brightness level</Description>
18     <Default>1.0</Default>
19     <Minimum>0.0</Minimum>
20     <Maximum>5.0</Maximum>
21   </PropFloat>
22   <PropFloat>
23     <Index>2</Index>
24     <Name>Blue brightness</Name>
25     <Description>Modify blue brightness level</Description>
26     <Default>1.0</Default>
27     <Minimum>0.0</Minimum>
28     <Maximum>5.0</Maximum>
29   </PropFloat>
30 </Shader>
31

```

**<Type>**

Effect, Colour or Transition

**<Name>**

the name of the effect

**<Description>**

a short description of the effect

**<PropFloat>**

Property Float (or **PropInt** for an integer)

**<Index>** unique index number for each property

**<Name>** name of the property

**<Description>** description of the property

**<Default>** the default setting for that property on initial selection

**<Minimum>** the minimum setting that the property can reach

**<Maximum>** the maximum setting that the property can reach

## frag files

Each frag code consists of 3 functions as seen in the example below:

- userTexturedMod()
- userSampleMod()
- userColourMod()

```

trans_venitianConcentric+Warp.frag x
1 void userTextureMod()
2 {
3
4 // Values linked to XML file contents
5 float amount = fPositionThroughEffect;
6 float blockCount = fCustom[0]; // 0 - 2000
7 float transSize = fCustom[1]; // 0.1 - 0.9
8 vec2 warpCenter = vec2( fCustom[2], fCustom[3] );
9 float warpAmount = fCustom[4];
10
11 // Looney Toons with warp
12 texCoordz -= warpCenter;
13 alpha = 1.0 - float_LooneyToonsEffect( blockCount, transSize, amount );
14 texCoordz += warpCenter;
15
16 modTexCoord = texfx_WarpScale( modTexCoord, warpCenter, 0.0, vec2( (pow(alpha, 0.25)*warpAmount)+(1.0-warpAmount) ) );
17
18 return;
19 }
20
21 void userSampleMod()
22 {
23     return;
24 }
25
26 void userColourMod()
27 {
28     return;
29 }
30

```

**fCustom[n]** lines link to the **PropFloat [Index value]** line of the xml.

**Note:** you should use **iCustom[n]** if integer values are declared in the xml.

For more information on writing frag files, see the examples in the **Using Delta Effects** section below.

## vert files

Vertex shader capability is currently in early development and as such, it is provided as is and will be expanded over time. We welcome your feedback on the possible further development of this area.

## Using Shader Effects

In Flatplane mode, Effects resources may be applied to the background (to affect all layers), or to media layers (to affect all media in that layer), in the DeltaGUI.

In Dome (Frustum) or Mesh mode, Effects resources may only be applied to media layers.

Click on the Effect to reveal its properties and a range of effect parameters in the form of slider controls.

Double-click to open the general properties dialog.

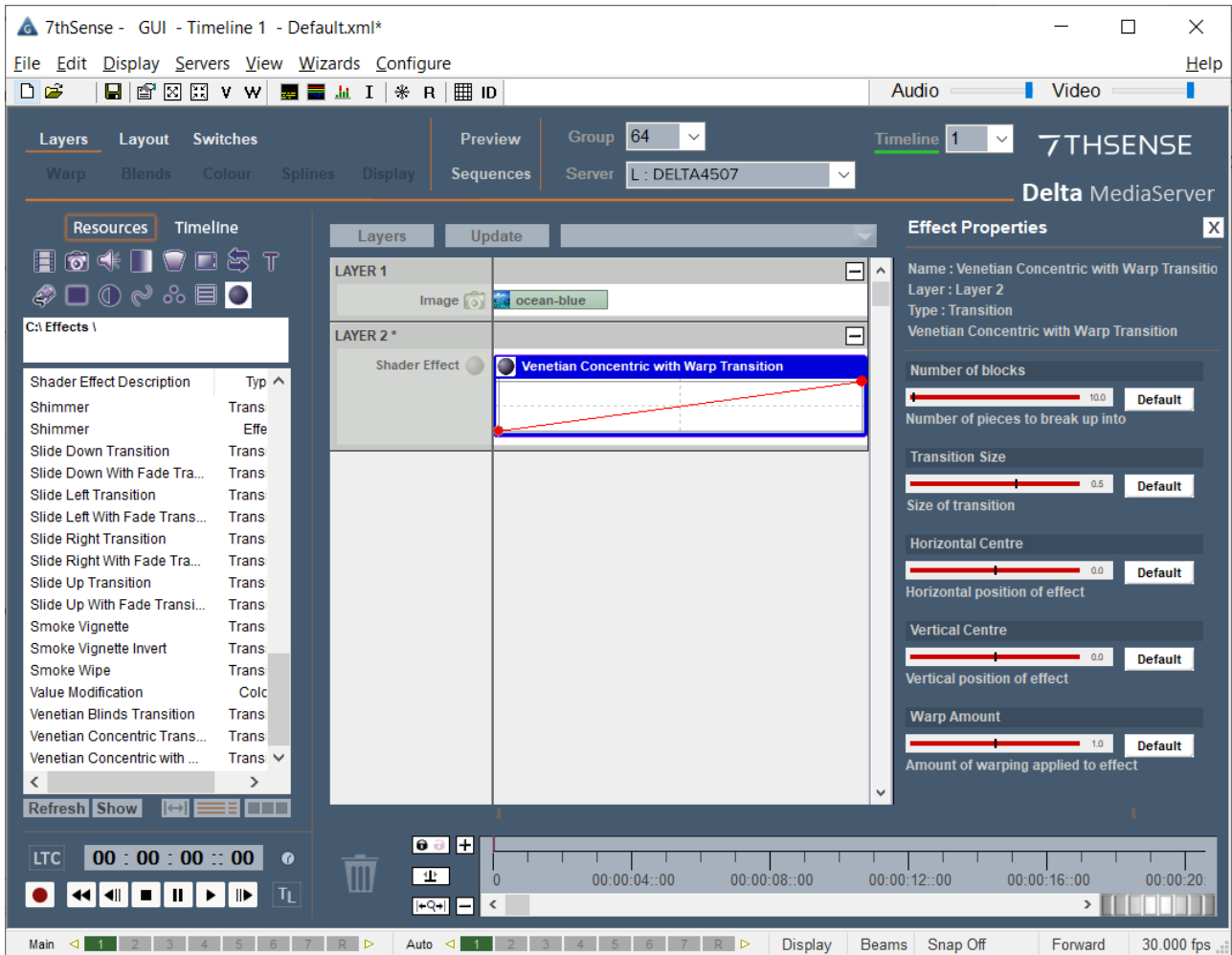



Note how the Effect parameters on DeltaGUI relate directly to the functions in the frag file:

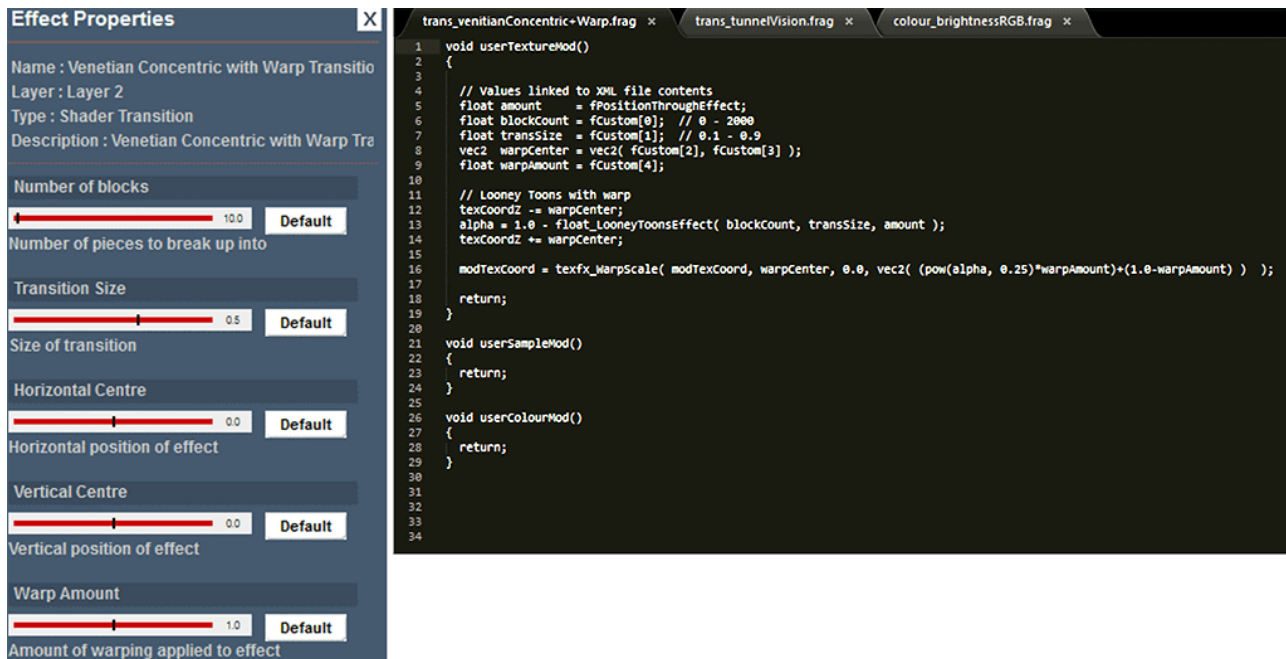

**Number of blocks** = **blockCount**, **Transition Size** = **transSize** and so on ...

## Using Multiple Effects

Effects are not additive, and are opaque, so as in image or movie resources, cannot be run simultaneously in the same layer. Only the first effect can be seen. However, you are able to run one effect after another in the same layer.

Where effects overlap in different layers, including the background, lower effects will only be seen during the overlap where an effect in a higher layer runs to or from transparency. So, for example, a Gradient Fade Transition in an upper layer can reveal a background Shimmer.

## Degradation Shader

Using the Degradation shader (available from December 2020) enables you to swap between 4:2:2 and 4:4:4, and/or between 8-bit and 10-bit on the fly.

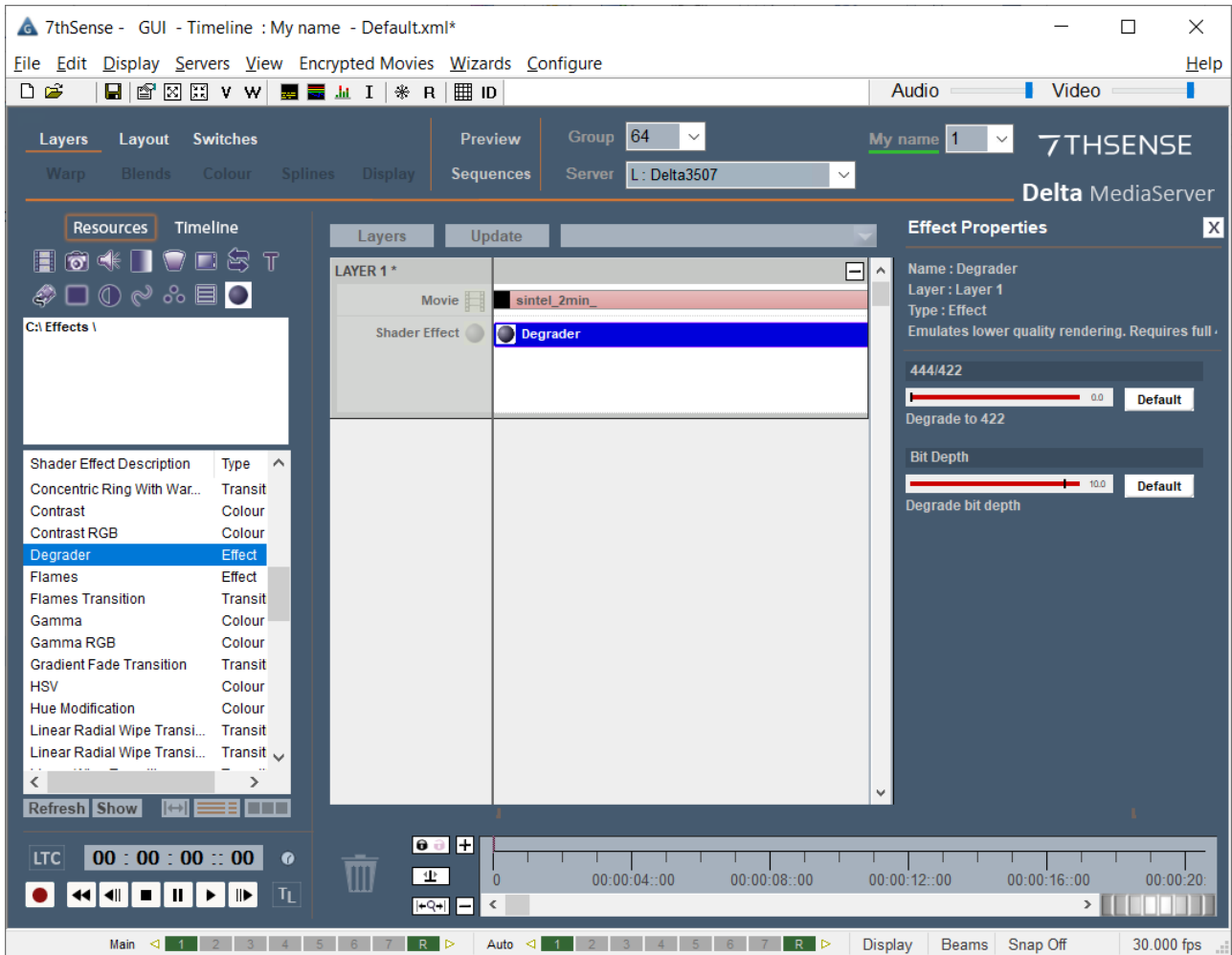

These are not true sliders:

- 1 = 4:2:2, anything less than 1 = 4:4:4
- treat the bit numbers as integers (e.g. 8.4 means 8-bit).

## Using Notch Effects



Licensed users of Notch visual effects can build their own effects, or use predefined Notch effects.

For the Notch file to be interpreted by DeltaServer, Notch Playback (or Builder) and an appropriate Notch key and driver are required to be installed on the Delta Media Server. Without this, Notch Effects resources cannot be processed.



When compiling a Notch Block for media server, create a 64-bit target, unless specifically requiring 32-bit. The Notch designer must expose those parameters that the player will want to manipulate, so that they appear in DeltaGUI as available (see illustration below).

These Notch Blocks are saved as DFXDLL files, which should be copied to the C:\Effects\Notch folder.

Notch effects files will now appear in the Effects resource area under their file names, when the list is refreshed. The refresh action creates the required Delta XML file. As with all effects, the DFXDLL and XML files must remain in the same location.

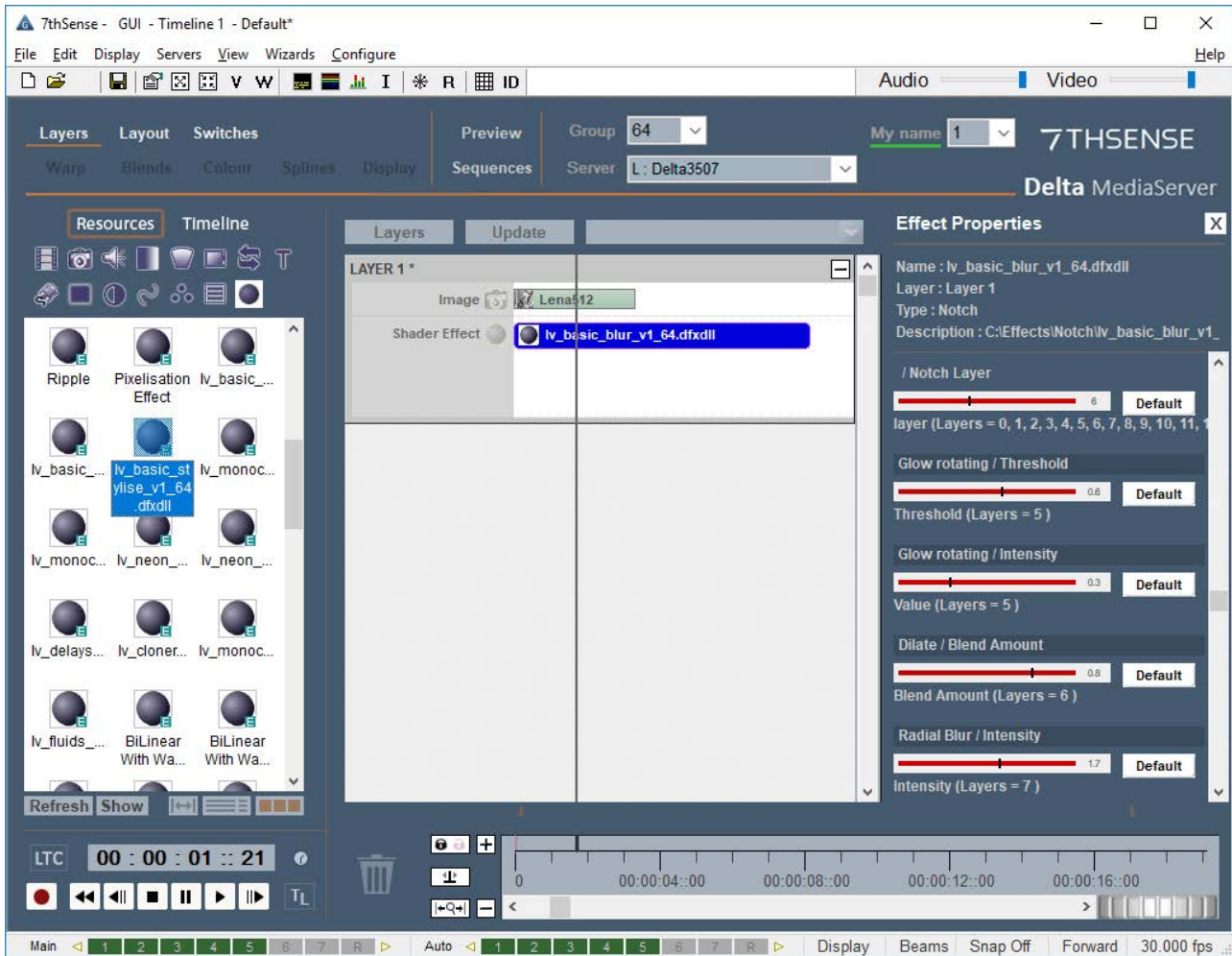

Note how here the /Notch Layer parameter stays visible at the top of the parameter stack, so that Notch layers can be selected and their parameters dynamically changed.

## Performance

The additional load placed on a media server will depend on the complexity of the Notch effect and the framerate being used.

## Creating Slideshows

This DeltaGUI wizard can help setup a quick slideshow (chain) of audio, images or movies (*Wizards > Create Slideshow*).

From the initial dialog, choose one or more audio files, images or movies (optionally filter the type using the check boxes in the top right), then click the add (+) button to add them to the list. If you hold Control down while clicking, you can select multiple resources before adding, hold Shift down to select multiple from the first selected resource.

Once in the lower Timeline Resources area, you can select them and remove (again with Control or Shift) by clicking the subtract (-) button. If you want to re arrange the order, select one resource, then click the up or down arrows in the right side to move.

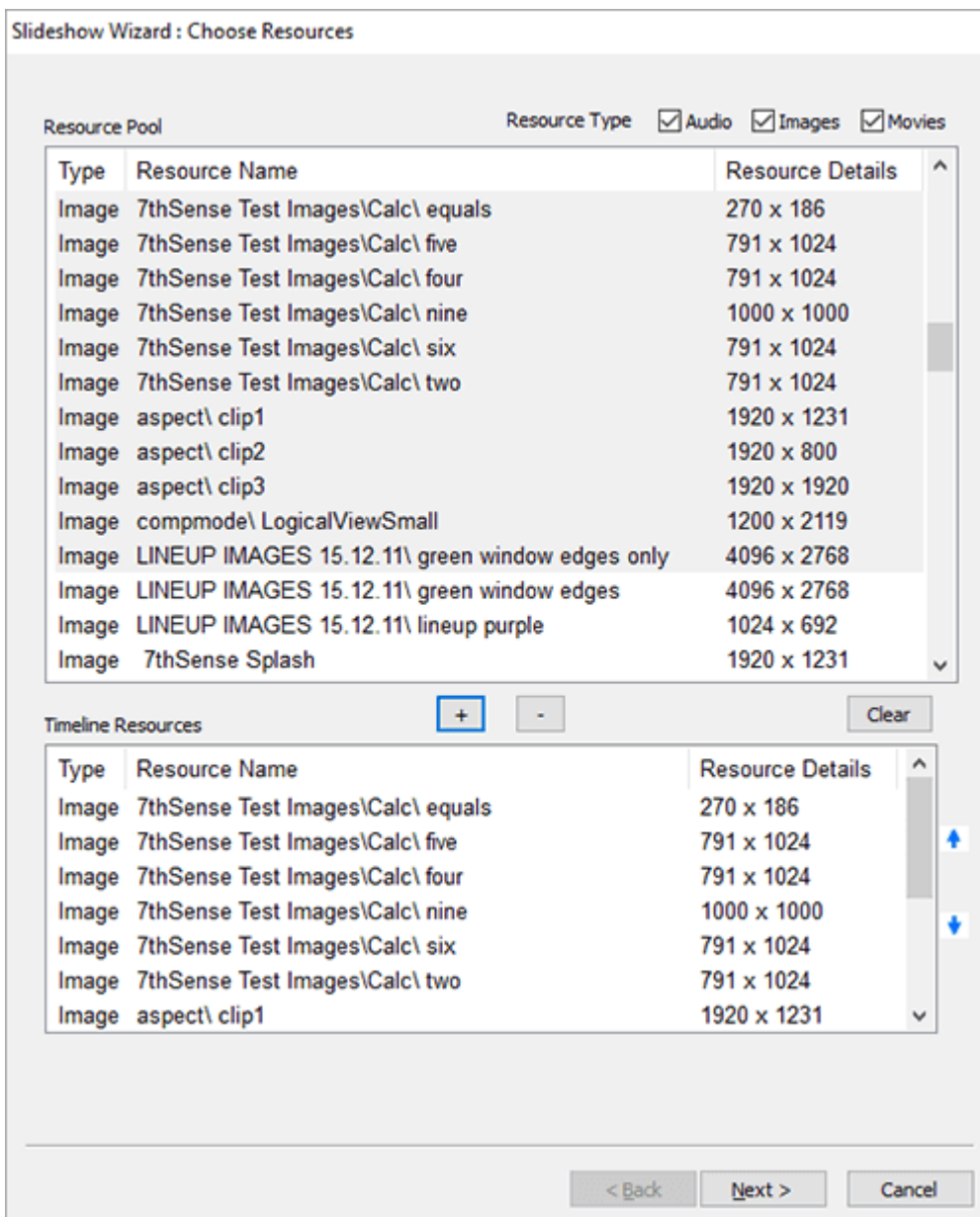

Once the list is complete, press the **Next** button to move onto the options page.

On this page, select the various options as described below and press **Create**. The result will be inserted into the requested layer, with each 'slide' being automatically faded up and down in turn. These remain separable resources, whose properties can be adjusted – or disrupted if treated casually.

**Slideshow Wizard : Choose Options**

**Timing**

Time per Resource  s      Transition Time  s

**Options**

Movie Auto Play <input checked="" type="checkbox"/>	Add Timeline Loop at end <input checked="" type="checkbox"/>
Use Movie Natural Length <input type="checkbox"/>	Placement <input type="text" value="Fullscreen"/>
Keep Existing Timeline Resources <input type="checkbox"/>	Layer <input type="text" value="1"/>
Keep Existing Warp & Blends <input checked="" type="checkbox"/>	

**Text Overlay Position**

Add Filename Overlay <input type="checkbox"/>	Overlay Position <input type="text" value="Top"/>
Text Size <input type="text" value="Small"/>	Background Transparency <input type="text" value="50%"/>
Text Colour <input style="width: 50px;" type="text"/>	Background Colour <input style="width: 50px;" type="text"/>

**Marker Options**

Add Marker at Each Resource Start <input checked="" type="checkbox"/>	Add Prior Marker at Before Resource Start <input type="checkbox"/>
Start Marker Stops Timeline On Play <input type="checkbox"/>	Prior Marker Stops Timeline On Play <input type="checkbox"/>
Number of Frames Before Resource Start <input type="text" value="10"/>	

**Mesh Options**

Eyepoint

Once the slideshow is created, save it as any other show to a new name.

## Timing

### Time per Resource

Defaults to 6s, choose this for the amount of time a resource is visible.

**Transition Time**

Defaults to 1 s, choose this for the amount of time crossfading. For no cross-fading, set to 0.

**Options****Movie Auto Play**

Turn on autoplay for all movies in the slideshow.

**Add Timeline Loop at End**

Add a loop at the end of the slideshow so when playing, it loops and restarts.

**Use Movie Natural Length**

Instead of the Time per Resource value (default 6s), use the movie's native length.

**Keep Existing Timeline resources**

Disabled : Delete existing (non-background) content, then insert all slideshow resources starting at frame 0.

Enabled : Do not delete existing resource on the timeline before creating the new slideshow. The slideshow contents will be inserted from the current timecode onwards, so you can build part of a slideshow in one session, move the current timecode, and choose different resources to insert at the new position, without disturbing the previous contents.

**Placement**

Fullscreen makes each resource fill the whole canvas

Fit Canvas will maintain the aspect ratio of the media, fitting the height or width to the whole canvas as required.

**Text Overlay Position****Add Filename Overlay**

When enabled, use the parameters in this area to show a text overlay of the current resource filename with a coloured bar behind it for clarity.

**Text Size**

V Small, Small, Medium or Large for the text overlay text size.

**Text Colour**

Colour of the text overlay.

**Overlay position**

Top or Bottom of the canvas..

**Background Transparency**

off (no bar), 25, 50, 75% and Opaque for the bar behind the overlay text.

**Background Colour**

colour of the bar behind the overlay text

## Marker Options

**Add Marker at Each Resource Start**

Places a marker at the start frame of each resource, named "Slide1", "Slide2" etc.

**Start Marker Stops Timeline On Play**

If enabled, each marker has the Playing Action set to Stop so that playing into each marker stops the timeline.

**Add Prior Marker Before Resource Start**

Add another marker before the resource start – the **Number of Frames Before Resource Start** box is used here. This is used if a customer wants to skip to just before the next item in the slideshow by using the Ctrl+Arrow keys in DeltaGUI.

**Prior Marker Stops Timeline on Play**

If enabled, Prior marker has the Playing Action set to Stop so that playing into it stops the timeline.

## Mesh Options

**Eye-point**

Choose which eye-point to place the slideshow resources on when in Mesh Mode.

**Create**

Press this to create the slideshow.



## External Controls

Once the show is created with the effects positioned on the timeline, you can control the effect properties via external control (Telnet, UDP or HTTP). TCP and UDP control is documented under the DeltaGUI **Help** button. HTTP is available through the latest version of our **Delta Web Service**, (see separate user guide).

### Secure Communications – from Delta 2.7 build 7

For secure communications, e.g. using PuTTY, SSH can be enabled (see [Communication Configuration](#) <sup>(102)</sup>).

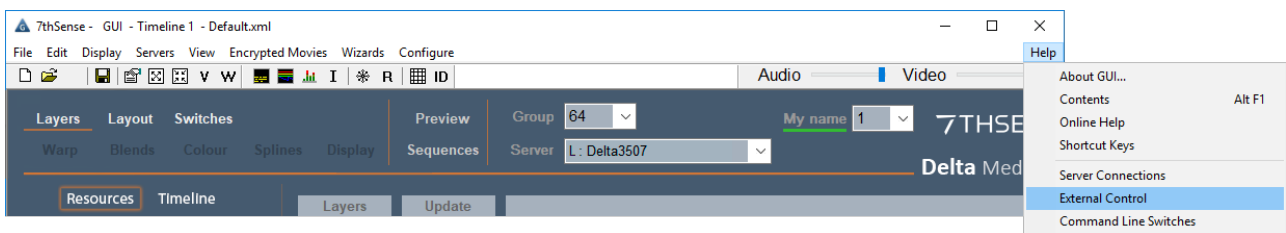

**7thSense Delta Media Server**  
 Delta Version 2.7 Build 6  
 External / Sequence Control Protocol  
[www.7thsense.one](http://www.7thsense.one)

- Commands are not case sensitive, and individual commands are activated by Carriage Return (Hex 0D, decimal 13)
- The character \ must be escaped with a second \ e.g. path="images\foldername"
- To specify a timeline for a command, add TL-X in the command (X=Timeline number or R for Reserve timeline. If you have named the timelines, you can also use TL-myname (note that timeline naming enforces unique names)
- Some commands (marked **I**) are non-realtime which could interrupt playback if playing, or will stop playback as part of the command.
- Non-realtime commands (marked with an additional **\***) - if Seamless Loop mode is enabled will not interrupt playback
- Non-Sequence commands (marked **E**) - Some commands are external control commands only, not sequence commands
- Sequence Only commands (marked **S**) - Some commands are sequence commands only, not external control commands
- Optional parameters or choices between parameters are enclosed in []

PLAYHEAD COMMANDS			
Command	Arguments	Description	Examples
CUE	None	Cue the show & wait for the play command	
PLAY	None	Play the show (no Cueing)	
STOP	None	Stop the show	I
RECORD	None	Start recording. Details configured in GUI	I
ADVANCE	n	Step forward n frames (defaults to 1)	I
STEPBACK	n	Step back n frames (defaults to 1)	I
REWIND	None	Rewind the show to frame 0	I*
GOTOMARKER	'marker name' [play]	Move to a named marker on timeline (optionally play)	I*
GOTOFRAME	None	Move to the framenumbr specified (optionally play)	I*
GOTOTIME	timecode [framerate] [play]	Move to the timecode specified for the framerate (optionally play)	gototime 00:00:12:24:30 - goes to 12 secs and 24 frames at 30fps gototime 00:01:02:4@60 play goes to time at 60fps
RATE	None	Set the framerate to n frames per second	I
RATESCALE	None	Modify the default framerate dynamically (0.1 - 4)	
SMPTE	[on/off]	Enable or disable tracking an external SMPTE timecode	I
CLIPSEARCH	clip=[next / previous] [play=true/false] [currentstart=true/false]	Search for the start of the next or previous clip (any visual resource such as movies, images, videocapture), optionally play immediately if currentstart is true, it will find the start frame of the current visual resource. By default, currentstart is false, meaning it will find the start of the clip prior to the visual resource which is currently in scope and also loop round to the first or last resource.	I
MARKERSEARCH	direction=[next / previous] play=[true / false]	Stop, search for the next or previous marker in the timeline, move to that marker and optionally play	I
REVERSEPLAYBACK	reverse=[true/false]	Turns reverse playback on[true] or off[false]	reverseplayback reverse=true

AUDIO COMMANDS			
Command	Arguments	Description	Examples
SETSPEAKERMIX	name L C R LS RS LFE LSide RSide	Set this audio files 8 speaker volumes in percent.	
SETGLOBALEG	1 2 3 4 5 6 7 8 9 10 11 12 13 14 15 % [preset / enable / disable]	Set the 15 frequency band level in percent from -100 to +100	
INITAUDIO	None	Note - if no forced options are used, audio will be reinitialised with existing options	

Connect to your server IP using appropriate software (e.g. **puTTY** in this example) to access the Delta show.

Type commands into the console (e.g. **status**) to return the data required

```
ApplicationName Deltaserver.exe

Welcome to the 7thSense Delta Telnet interface, Help [CR] for commands
SERVER : GUI_PC
READY
status
SERVER      : GUI_PC (Leader)
FILE       : Default.xml
MODE       : Stopped
CURRENTFRAME: 345
FRAMERATE  : 30.000
LICENCE    : 1.7.2016
MOVIEDRIVES : C C C C C C
OTHERDRIVE : C
GRAPHICS   : 1920 X 1080 60 HZ
SMPTE     : OFF OFF OFF OFF OFF OFF OFF OFF
AUDIOLEVEL : 100
VIDEOLEVEL : 100

OK
█
```

You are now able to access and control the properties of effects that you have on the timeline. Some examples include:

**listeffects source=timeline**

returns

*name=Venetian Concentric with Warp Transition:ctrlname=ShaderEffect\_11313*

```

ApplicationName Deltaserver.exe

Welcome to the 7thSense Delta Telnet interface, Help [CR] for commands
SERVER : GUI_PC
READY
status
SERVER      : GUI_PC (Leader)
FILE       : Default.xml
MODE       : Stopped
CURRENTFRAME: 345
FRAMERATE  : 30.000
LICENCE    : 1.7.2016
MOVIEDRIVES : C C C C C C
OTHERDRIVE : C
GRAPHICS   : 1920 X 1080 60 HZ
SMPTE     : OFF OFF OFF OFF OFF OFF OFF OFF
AUDIOLEVEL : 100
VIDEOLEVEL : 100

OK
listeffects source=timeline
name=Venetian Concentric with Warp Transition:ctrlname=ShaderEffect_11313
OK
█

```

**geteffectparams ctrlname=ShaderEffect\_11313**

returns the parameters of the effect

(resource and property names and values)

```

name=Slide Right Transition
name=Slide Up With Fade Transition
name=Slide Up Transition
name=Smoke Wipe
name=Smoke Wipe
name=Smoke Wipe
name=Block Warp Transition
name=Venetian Blinds Transition
name=Venetian Concentric with Warp Transition
name=Block Warp Transition
OK
listeffects source=timeline
name=Venetian Concentric with Warp Transition:ctrlname=ShaderEffect_11313
OK
geteffectparams ctrlname=ShaderEffect_11313
resourcename=Venetian Concentric with Warp Transition:effectname=Venetian Concentric with Warp Transition:effecttype=Shader Transition
propertyname=Number of blocks:value=35.81:min=1.00:max=500.00:type=float
propertyname=Transition Size:value=0.28:min=0.10:max=0.90:type=float
propertyname=Horizontal Centre:value=-0.56:min=-1.00:max=1.00:type=float
propertyname=Vertical Centre:value=0.27:min=-1.00:max=1.00:type=float
propertyname=Warp Amount:value=0.50:min=0.00:max=2.00:type=float
OK
█

```

External controls also allow you to change the properties of an effects resource:

**Seteffectparams ctrlname= ShaderEffect\_11313 propertyname="Vertical Centre" value=0.8**

```
name=Smoke Wipe
name=Block Warp Transition
name=Venetian Blinds Transition
name=Venetian Concentric with Warp Transition
name=Block Warp Transition
OK
listeffects source=timeline
name=Venetian Concentric with Warp Transition:ctrlname=ShaderEffect_11313
OK
geteffectparams ctrlname=ShaderEffect_11313
resourcename=Venetian Concentric with Warp Transition:effectname=Venetian Concen
tric with Warp Transition:effecttype=Shader Transition
propertyname=Number of blocks:value=35.81:min=1.00:max=500.00:type=float
propertyname=Transition Size:value=0.28:min=0.10:max=0.90:type=float
propertyname=Horizontal Centre:value=-0.56:min=-1.00:max=1.00:type=float
propertyname=Vertical Centre:value=0.27:min=-1.00:max=1.00:type=float
propertyname=Warp Amount:value=0.50:min=0.00:max=2.00:type=float
OK
seteffectparams ctrlname=ShaderEffect_11313 propertyname=Vertical Centre value=0.8
propertyname is missing
OK
seteffectparams ctrlname=ShaderEffect_11313 propertyname="Vertical Centre" value=0.8
OK
█
```

Note the quotation marks around the **propertyname**: without them the system will not see the name (as in the first example above)

Your changes will be reflected in DeltaGUI and display output.

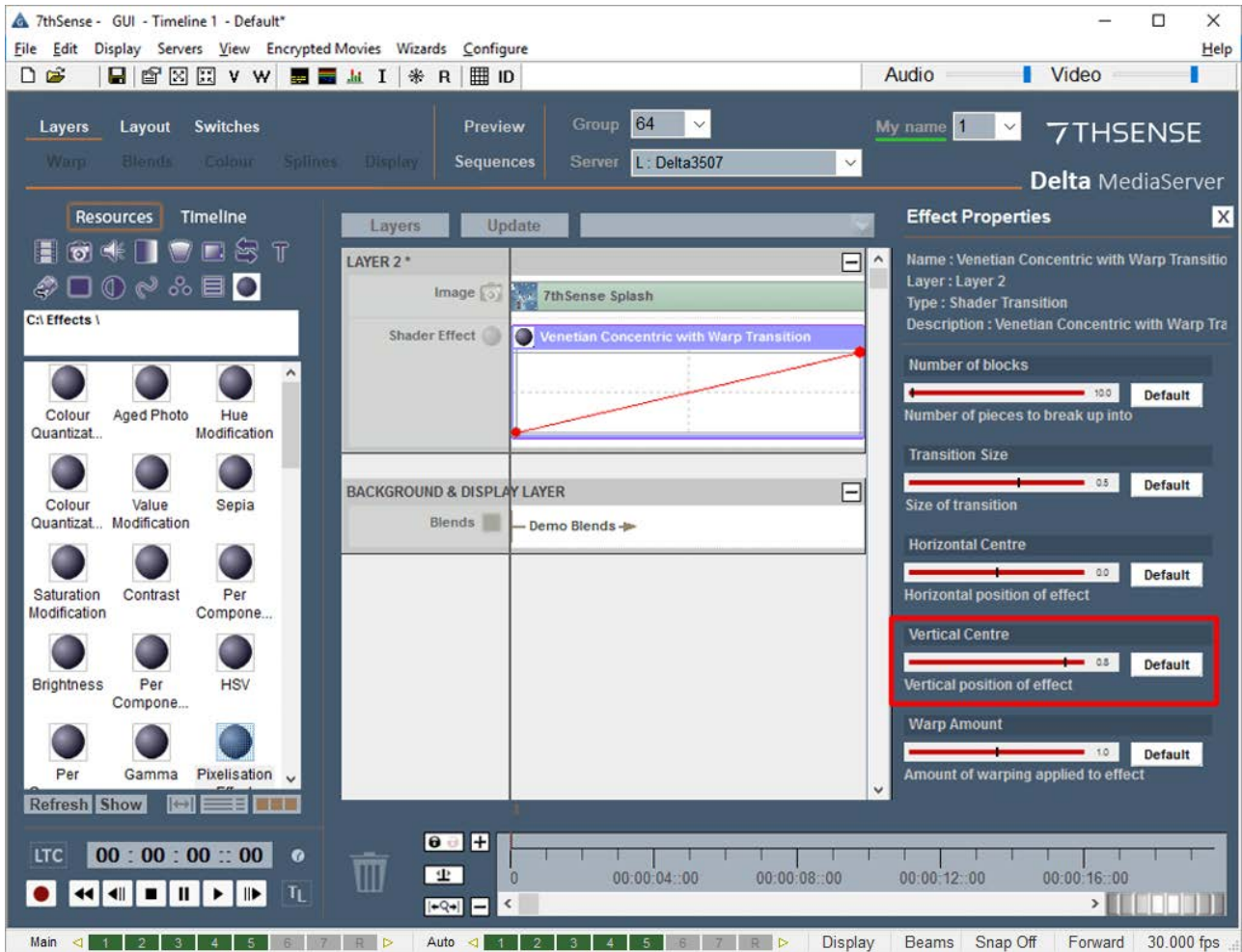

➤ See [Appendix A: External Control](#) <sup>439</sup>

## Viewing and Previewing Shows

Delta (v. 2.4 and later) has a web browser-based Preview function via Web Real-Time Communication (WebRTC). [Please see Delta User Guides prior to v. 2.4 for information on previous Preview functionality.]

WebRTC streaming allows Delta Playback to be previewed in a browser (Firefox or Chrome are recommended). Preview is available from either DeltaGUI, or by logging in remotely to any connected Delta server via IP address, using **Delta Web Service**, which is based on the widely-used open source Apache web server.



**DeltaMonitor** needs to be running. This should already be set up to run automatically on start-up on your Delta server. The icon should show in the Windows system tray (bottom-right of the Windows taskbar).

### Enable WebRTC Preview

To use the WebRTC preview capability you must enable WebRTC Preview in the DeltaGUI Preferences screen:

- In DeltaGUI, click *Configure > Preferences > Preview Window*

Preferences : 'Delta2901' at 10.100.101.95

**Preview Window**

Configure Preview Windows

- Large preview sizes may slow playback down if viewing while playing
- This depends on graphics hardware on both server and GUI PCs
- Note that if Hardware Output is enabled, this overrides the Network Preview Format

Server (Hardware) Preview Format: Off

GUI (Network & Recording) Preview Format: 512 x 384

Custom Format: 1920 x 1080 pixels

WebRTC Preview

Enable WebRTC Preview

Peer Name: DeltaServer

Port: 7878

NDI Preview

Enable NDI Preview

OK

Cancel

Click the Enable WebRTC Preview checkbox, then click OK.

Preview Format is also used to fit the web Preview frame to your canvas.

**Note:** The Peer Name and Port details default in automatically but even if you change them, Preview is programmed to search and find appropriate details on connection, so it won't matter if you want to call the server by another name.

## Enable NDI® Preview (from Delta 2.6)

With an NDI viewer, you can instead preview a show in an NDI monitor such as [NewTek NDI® Studio Monitor](#), or [MediaLooks](#). The size viewed via NDI is the *Display > Preview Setup > Canvas Size*:

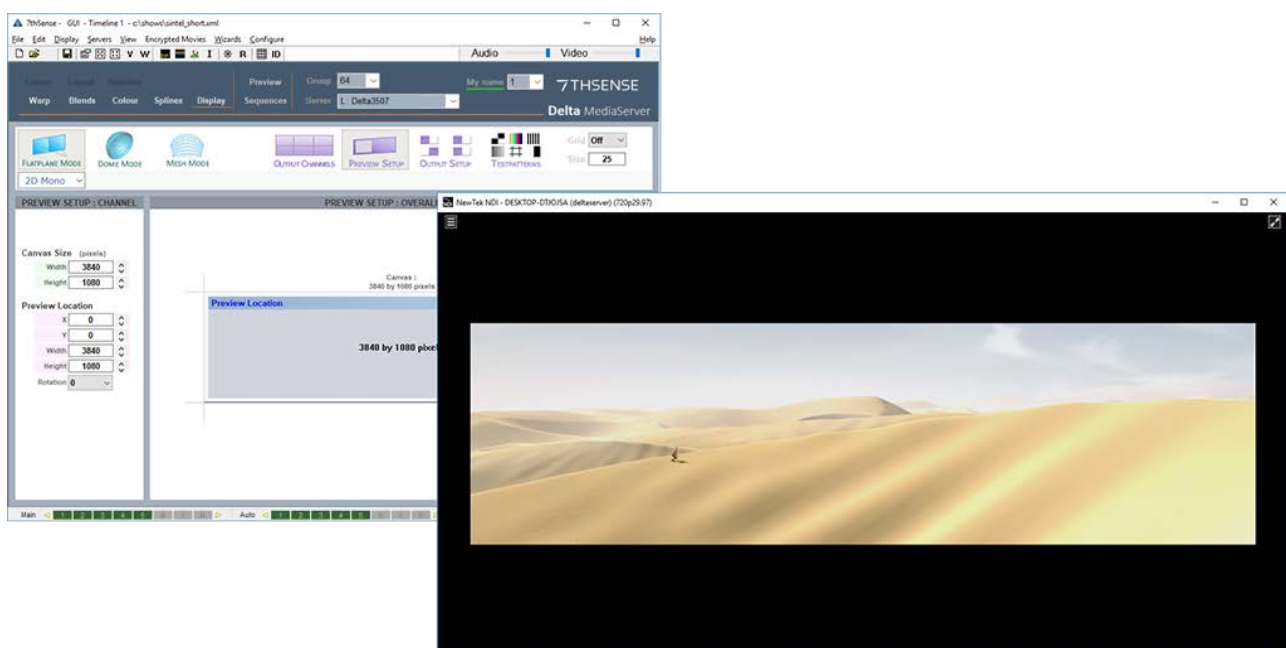

Note that to view the info., stats or graph in NDI, you will need to turn these on in the usual way through the Config button in Web Preview (with WebRTC also enabled).

For displaying movie frame title, number or time, you can apply a Movie Timecode text resource. See [Resource Editor: Text](#) <sup>(334)</sup>.

## Using Delta Preview

The preview window is launched from DeltaGUI or from within Delta Web Service. See [Managing Delta-Servers: Delta Web Service](#).

## From DeltaGUI

Click the Preview button (top-centre of DeltaGUI). The Preview window opens in a new browser window and shows live preview of the show. From Delta 2.7, this is an https:// connection to the IP address of your server, port 8484 (e.g. https://1.100.101.227:**8484**).

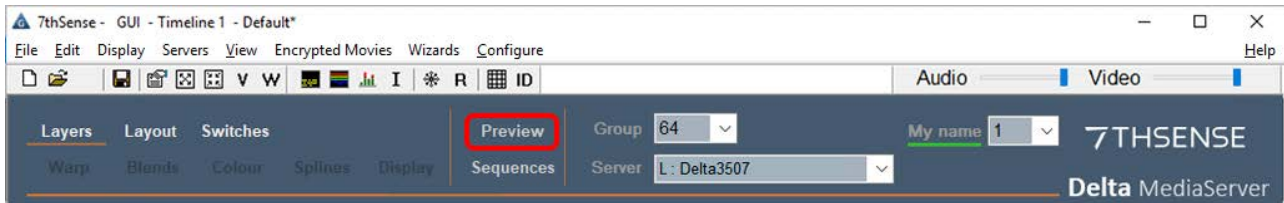

## Delta Preview Window

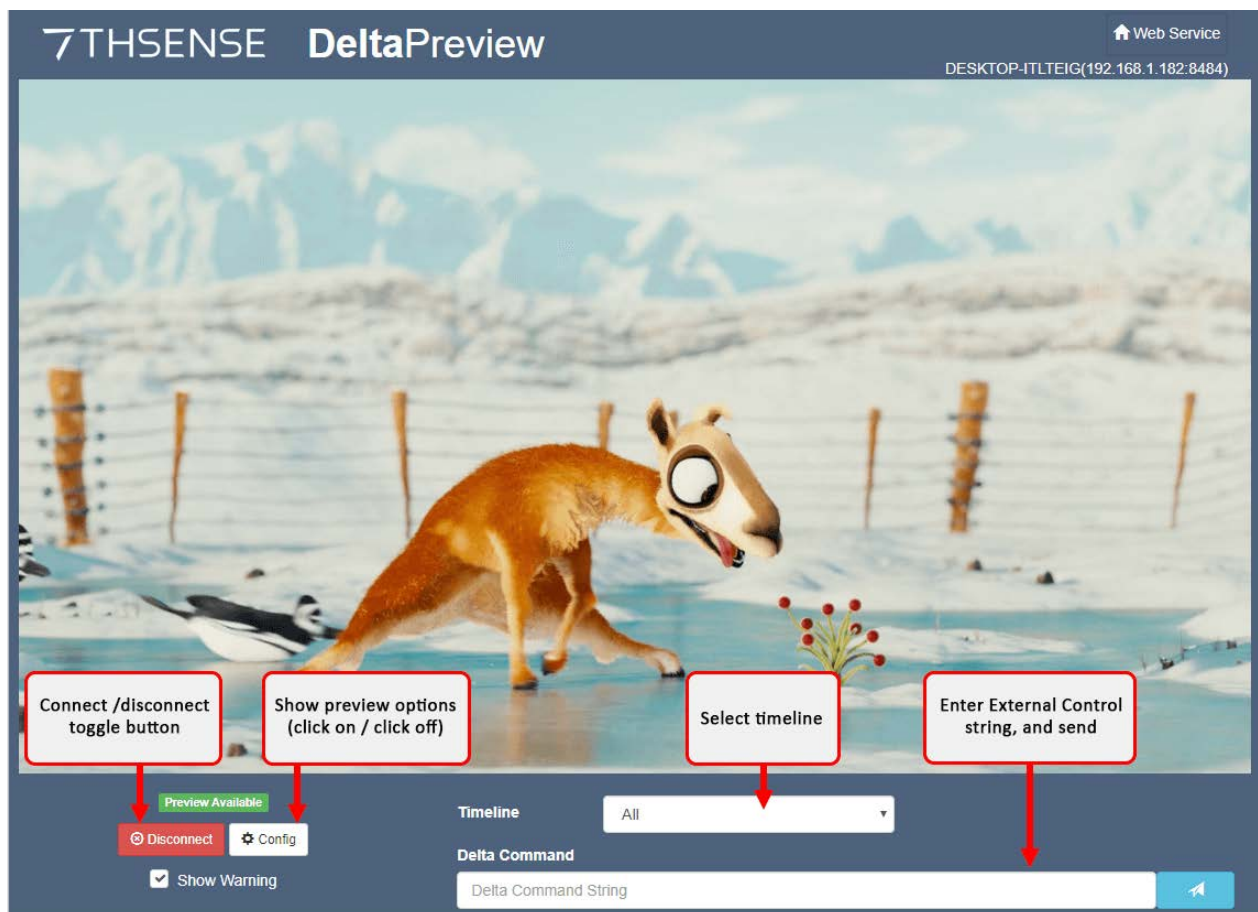

The preview window in browser reflects live playback and has the same options to show information, playback statistics, performance graph and audio VU meter as the playback window. Click Config:



The screenshot displays the DeltaPreview application interface. At the top, the title bar reads '7THSENSE DeltaPreview' and 'Web Service'. The main content area shows a 3D rendered scene of a brown llama-like creature in a snowy, mountainous landscape. Overlaid on the scene are several performance graphs: a yellow line for Frame Time, a green line for GPU Time, and a blue line for Audio. A log window in the top-left corner displays system messages. A 'Preview Config' panel is open in the bottom-left, showing options for 'Auto Connect Preview', 'Audio', 'Graph', and 'Stats'. A 'Delta Command' input field is visible in the bottom-right.

Click Config again to close the options. The size and position of stats text and graph lines are controlled from the Playback window, not the browser page.

From here you can navigate to other Web Service features. See [Delta Web Service](#) in the user guide, *Managing Delta Servers*.

- See more controls and explanation in [Playback Window](#) <sup>33</sup>

## From Stack Overview (optional install)

Open a web browser and connect to the IP address of your server, port 8000 (e.g. 1.100.101.227:8000). From **Overview**, select the required server, and connect to preview live:

The screenshot displays the 7THSENSE STACK Overview page. At the top, there's a navigation menu with 'Landing Page', 'Annotate', 'Backup and Restore', and 'Overview'. The main content area is divided into several sections:

- Server List:** A table with columns: SERVER NAME, IP ADDRESS, GROUP, LEADER, HEALTH, STATE, and GEOLOCK. It lists several servers, including 'Delta907NAD' and 'Delta907D'.
- Detailed Status:** A section showing system information like Delta Version (2.424), Playback FPS (30), Motherboard (ASUSTEK COMPUTER INC. P9X79 WS), GPU 1 (AMD FirePro W9000), and various memory and storage metrics.
- Channel Config:** A 'Canvas (4118 by 1546)' section showing a grid of 6 channels (Chan\_1 to Chan\_6) with their respective resolutions.
- Live Preview:** A section with a 'Connect' button and a dropdown menu for 'Auto connect', 'Graph', 'Stats', and 'Audio'. It shows a live preview of a 3D scene.

For full details on the Stack web interface, see the [DWS User Guide](#).

## Preview External Controls

The Delta Command line accepts the **External Controls** as listed in DeltaGUI, *Help > External Control*. Click the send button to send the string command to the Delta server.

## Recording

---

A show, or part of a show, can be recorded to disk, in effect compositing all the layers into one for reduced load, or playback on another machine.

Recording is also used for carving media between channels to optimise bandwidth, by presenting each channel with only its required part of the media.

See the section on [Real-Time Recording](#)<sup>424</sup> if you need to record live capture to disk as well.

[Art-Net Recording](#)<sup>426</sup> enables Art-Net inputs to be recorded and then rerun in simulation scenarios. This may be useful in optimising inputs, or to allow inputs to be simulated as shows are developed.

To set up recording, click the red Record button on the timeline controls:

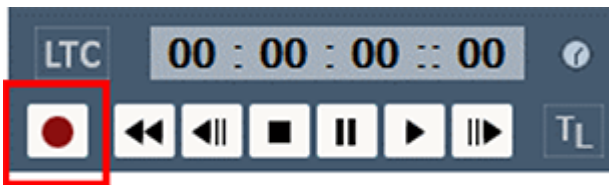

This will bring up the main dialog, with three tabs, for each kind of recording.

(Note that recording is not enabled in reverse playback mode.)

## Record a Show or Carve Media

---

Clicking the Record button on the timeline controls brings up the following dialog.

### Create the job

Here two recording jobs have been set up:

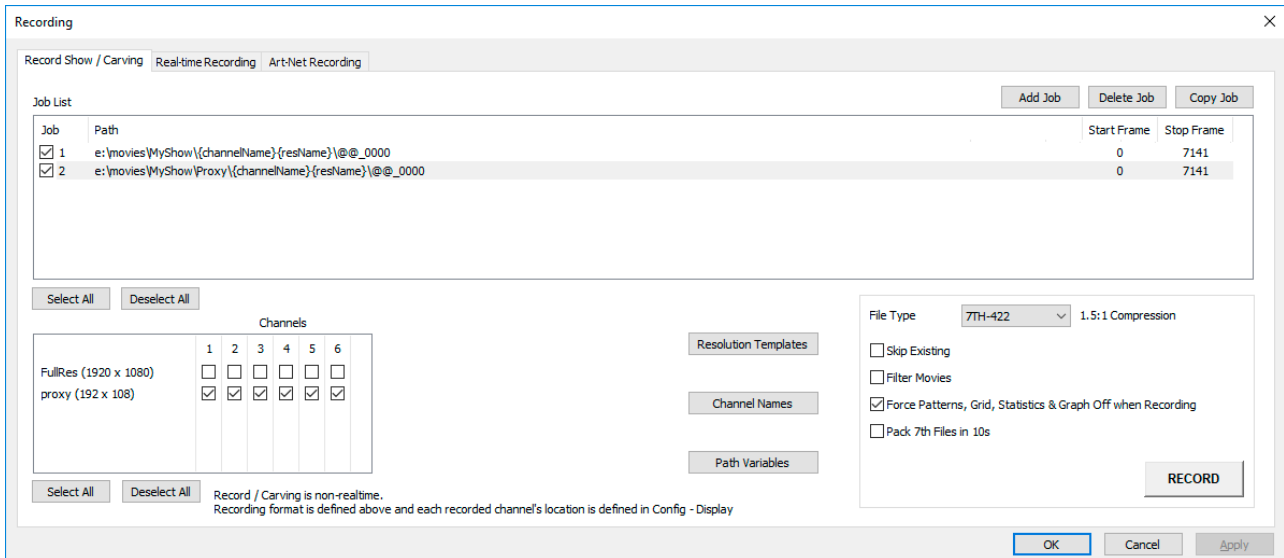

A **Job** is a recording event, comprising channel selection, duration, resolution, output format and destination. A number of jobs can be created, and checked items will run sequentially. In this example, two recording jobs are set up, one at full resolution and one at low resolution.

## Path Variables

This button offers help on using variables to define the path names:

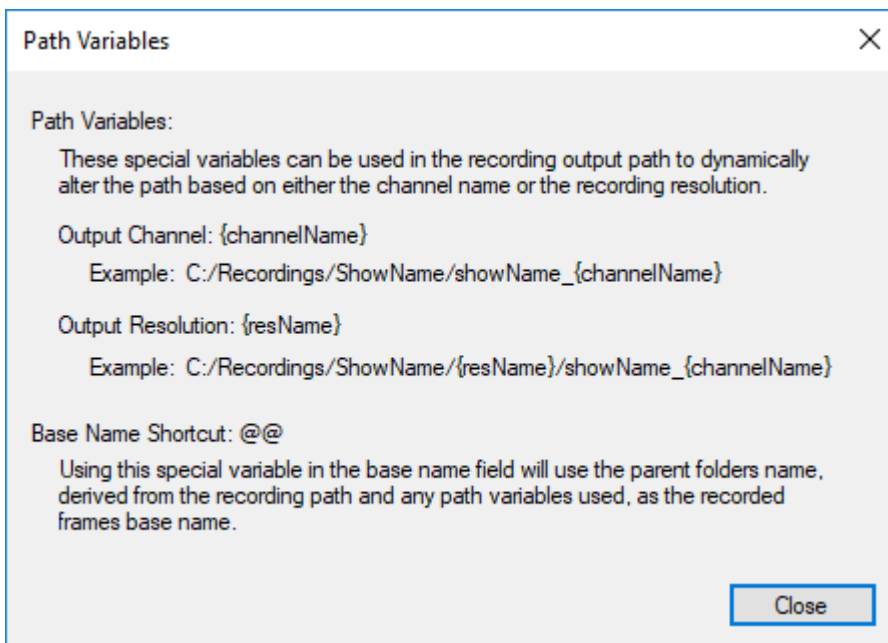

## Add a recording job

Start by adding a job. You can also select an existing job, press 'Copy' and edit the details to create a similar one:

Double-click any job to edit its details.

### Path

Usually in E:\movies, append the folder name you want to use. (Here, we just called it 'MyShow'). In this folder, **if you are recording more than one channel**, assign the channel subfolders using these variables exactly as written here, for automatic naming:  
 {channelName} will append the channel names you have given in your show (they can be renamed before you record)  
 {resName} will append the name of the resolution template (see below) that this job will use

### Base Name

This is the name for the recorded movie, which will be the prefix for every frame, to be followed by the automatic addition of frame numbers and file extension. If the frame name is to be the same as the channel and resolution variables used in the path, type @@

### Offset

This is the number from which you want the frame sequence to begin.

### Number of digits

Choose enough digits for the number of the last frame (including any offset).

### Start and Stop

These can be defined in SMPTE, frames or seconds, or 'Set to Show Length' for the whole length of the show.

Press **OK** to return to the main dialog.

## Configure the Output

### Resolution Templates

Multiple resolution templates can be added and named:

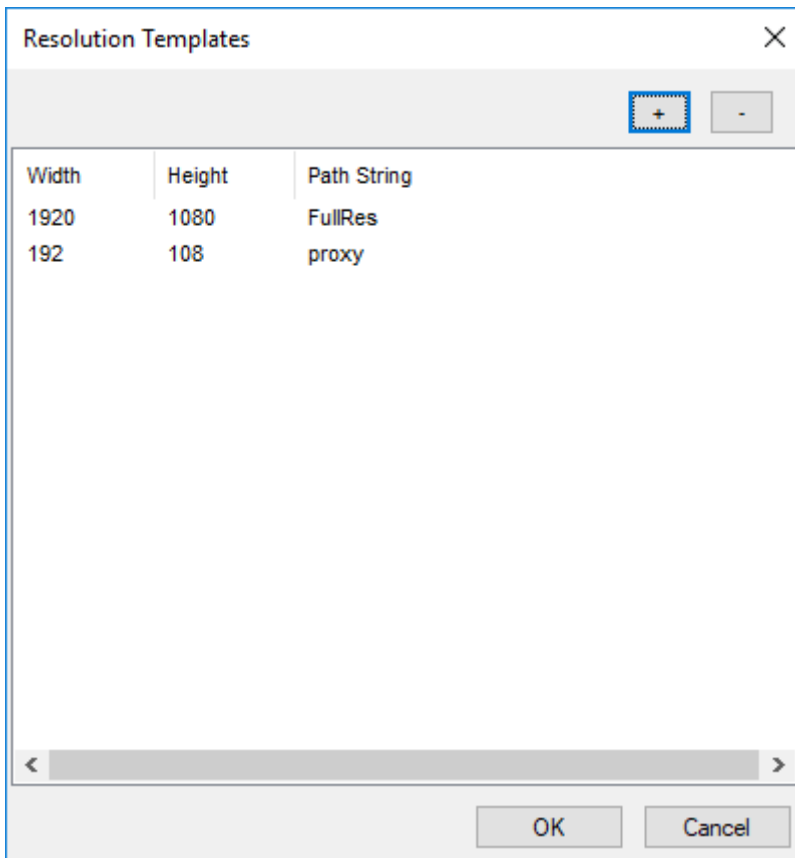
**Channel Names**

This is not local naming, but the names already assigned in the show. They may, however, be edited here.

**Channels (to record)**

Select the required job and use the checkboxes to select which channels are to be recorded for this job.

**File Type**

Choose your required format from the drop-down list:

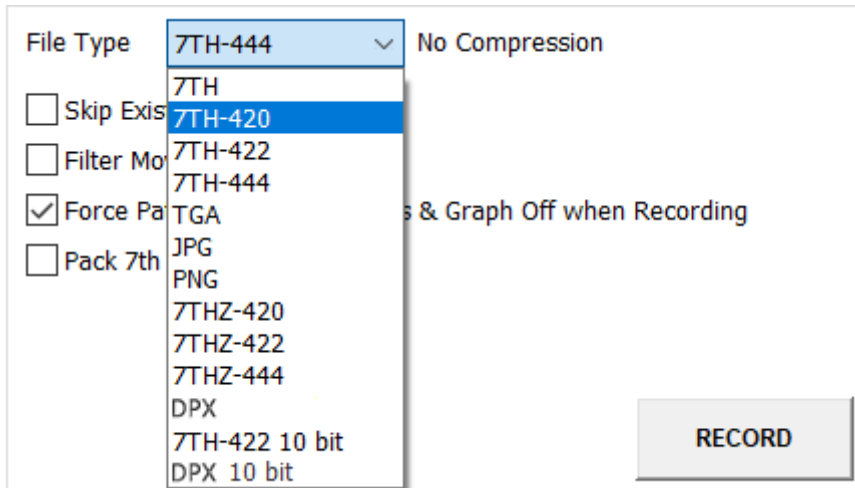

Note that JPG and PNG frame sequence formats cannot be played back on Delta.

**Skip Existing**

Skip any movie files already in that folder. If recording a large show in parts, use File Offset to resume numbering the frames at the right point each time and Skip Existing to avoid inadvertent frame duplication.

**Filter Movies**

With Filter Movies on, during recording, there is an additional filtering render pass performed (called MipMapping) which can improve the quality of the recorded imagery, especially if there is also a change in resolution such that the output recorded resolution is lower than the source material.

**Force Patterns, Grid, Playback Statistics and Graph**

Check this to ensure these diagnostic and alignment aids are turned off before recording.

**Pack 7TH Files in 10**

This should be left blank for an SSD based server, but for standard HDD based servers, this should be checked.

**Record the Show**

Pressing RECORD will start the server recording as configured above, the Recording button will go red and the record button on the main GUI is shown surrounded by red. You can press the timeline Stop control to stop recording or press the red RECORDING button:



## Files output from this example

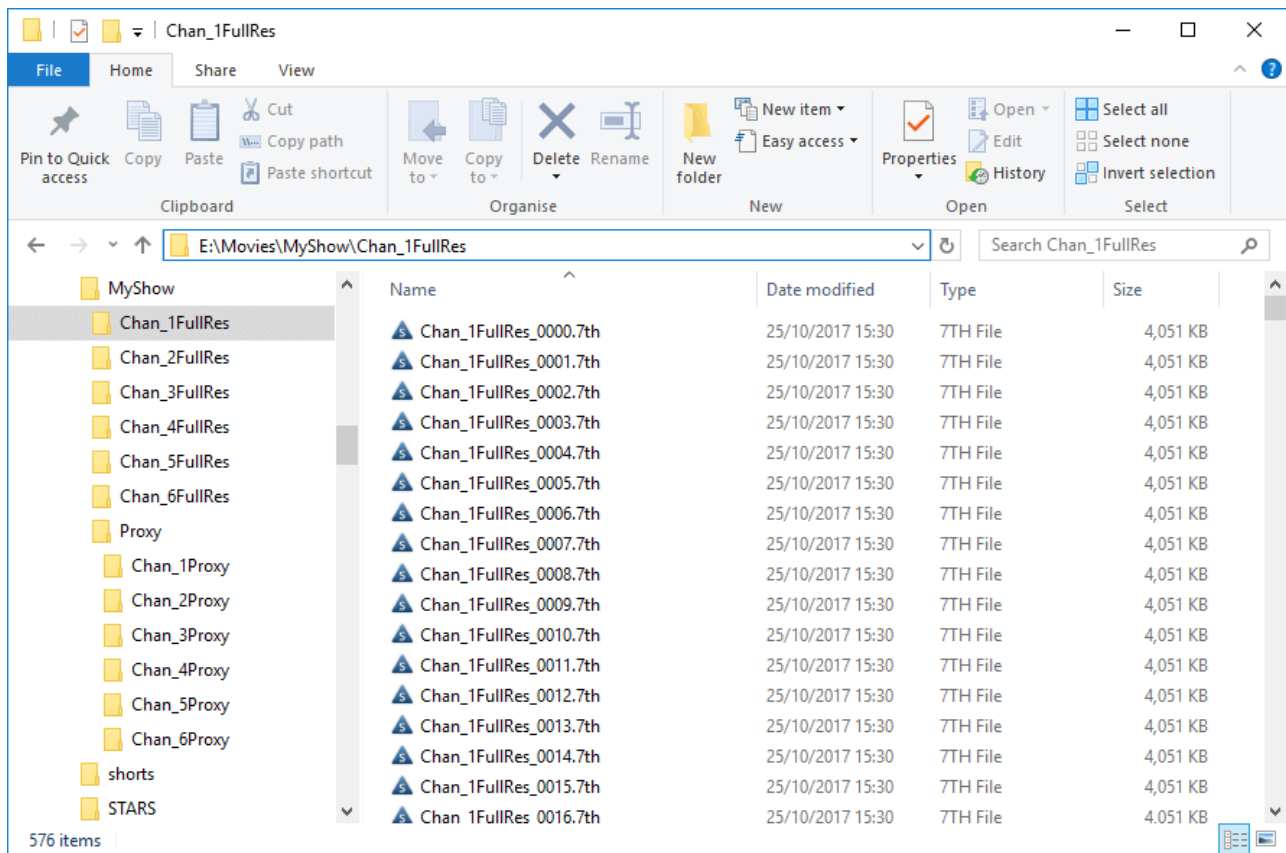

**Note** that for multiple channels, the frame is advanced, then all channels are saved to disk for that frame, before moving onto the next frame.

➤ See also: [Carving Media for Dome Displays](#)

## Real-Time Recording

Real-time recording (previously referred to as Preview recording) is recording of every frame to disk (including live capture). This is in contrast to the standard recording, which is non-real-time (so would not capture any live capture frames to disk). Real-time recording is started and stopped from the DeltaGUI dialog, external control or sequence commands (see below) and the record path and filename are configured in Preview Recording page of the Recording dialog, or through commands below.

**Note:** Real-time recording must be enabled in *Preferences* > *System* 'Enable Real-time recording'.

Real-time recording is independent of the play mode of the timeline, so it can record all output including stopped sections of a show.



Recording a show, and real-time recording cannot be performed simultaneously: starting one after the other will stop the first.

The recording location can be accurately set in the Recording dialog (press the Record button to access) or by using the external control / sequence commands:

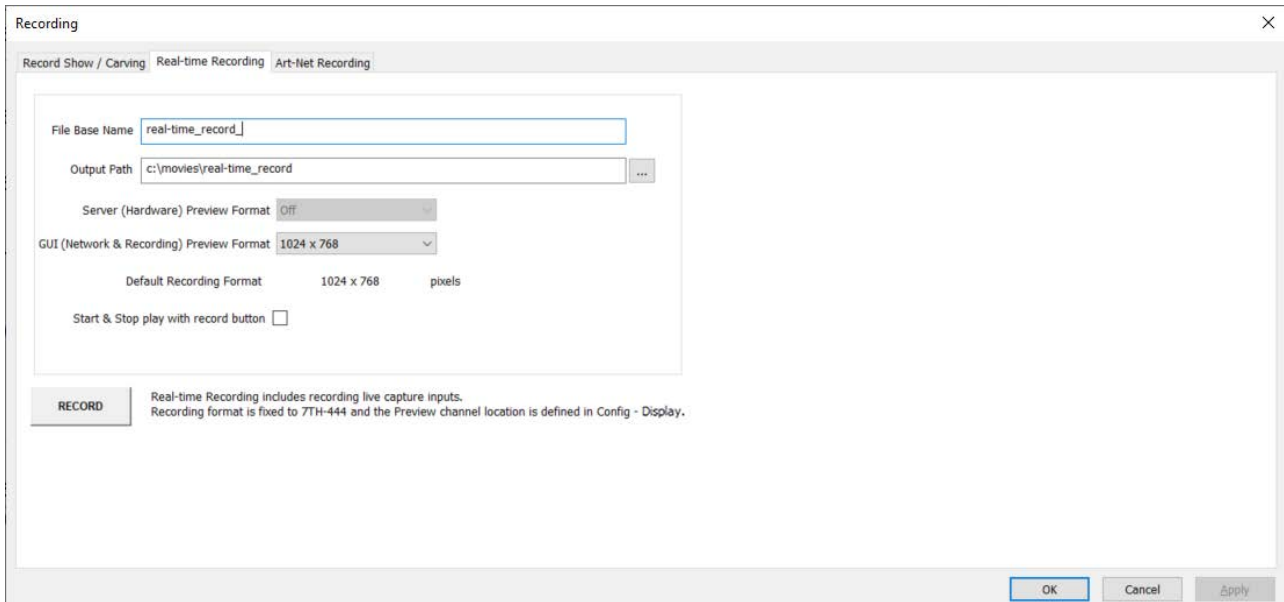

In the dialog above, the output resolution of the recorded movie is linked with the Preview format, so choose one of the presets from the **GUI (Network & Recording) Preview Format** dropdown, or choose custom and enter the **Custom Recording Format** in the boxes provided.

### Start & Stop with record button

Enabling this option starts the timeline playing after you press the Record button on this page – note that due to the nature of preview recording, there will be additional recorded frames before playing and after stopping.

Note that if **Server (Hardware) Preview Format** is selected (assuming preview hardware is fitted to the server), this chosen format overrides the preview & recording format.

Once Real-time Recording is started by pressing the Record button on the dialog, the button turns yellow to show recording is active and the Record button on the main GUI window is surrounded by yellow as well.

Note that pressing the yellow Recording button stops real-time recording (or an external control command) – by design, Play & Stop do not stop real-time recording.

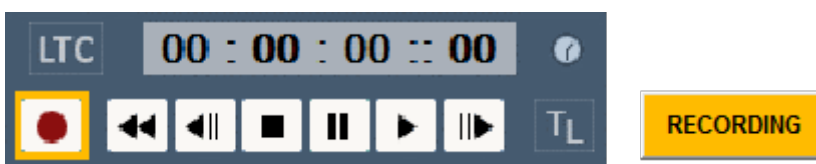

## External Control / Sequence commands

REAL-TIME\_RECORD mode=[start / stop / continue] Start or stop preview recording with the configured parameters. If disk is full, you will get back REAL-TIME\_RECORDSTATUS=DiskFull and recording will not start. If already recording and send in start or continue, you will get back REAL-TIME\_RECORDSTATUS=AlreadyRecording and recording will not start

REAL-TIME\_RECORDSETTINGS [fullpath=path] [filename=file] [startframe=start] [stopframe=stop] lockgui=[true/false] [OutputPixels=W] [OutputLines=H] Set any of the preview recording parameters. If recording is already started, this command will be ignored and you get Status=Error StatusInfo=AlreadyRecording

Note that for a path, you must escape backslashes and quote like this: "e:\\Movies\\My Path"

REFRESHMOVIE drive=[A,B,C,D...Z] Refresh Movies in the specified drive to get an up to date list

DELETE\_DISKMEDIA [resourcename=name] [controlname=ctrl] Delete the specified resource from disk, pool and timeline permanently.

A typical usage would be to configure the record path and filename, then start recording with REAL-TIME\_RECORD mode=start, play the timeline for the active part, then issue REAL-TIME\_RECORD mode=stop. The show control system would then call REFRESHMOVIE drive=E to make the server aware of the new movie, use MEDIAINSERT... to insert it onto the timeline, and play the newly recorded movie. If this recorded movie is not required permanently, issue DELETE\_DISKMEDIA resourcename=recordedmovienam which deletes it permanently from the disk.

## Art-Net Recording

---

This feature enables Art-Net inputs to be recorded and rerun in simulation scenarios. This may be useful in optimising inputs, or to allow inputs to be simulated as shows are developed.

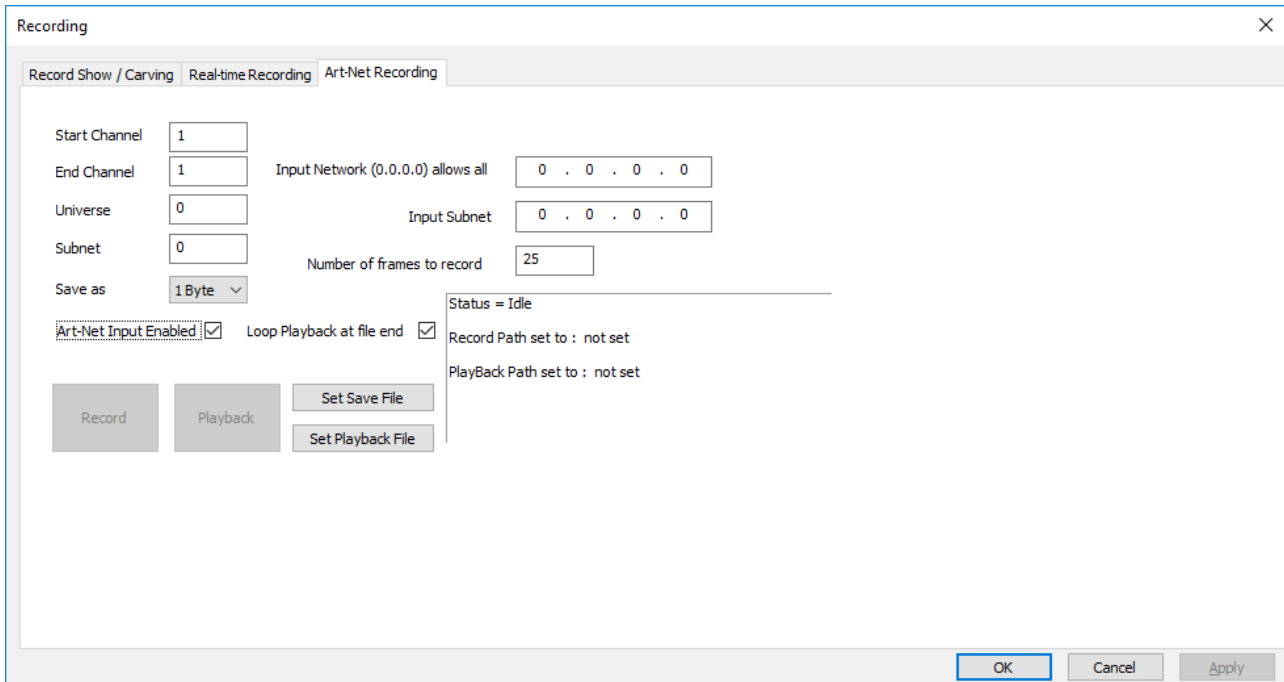
**Start**

first DMX channel to record

**End**

last DMX channel to record (recording includes all channels between Start and End)

**Universe**

Universe being recorded

**Subnet**

Art-Net Universe being recorded

**Save as**

the number of bytes which make up a data point to be recorded

**Input Network**

The IP from which the recording is being listened to

**Input Subnet**

The IP subnet being listened from

**Number of frames to record**

This is the number of Art-Net frames to record (not movie frames).

**ArtNet Input Enabled**

This is essentially the same checkbox that can be found in *Config > Preferences > ArtNet & DMX* to enable Art-Net input.

**Loop playback at file end**

Plays the Art-Net recording continuously until playback is cancelled.

**Set Save file**

Set the file to record to. When this is set, and Input is enabled, the Record button becomes available.

**Set Playback File**

The file to be read from, in order to playback Art-Net. Once this is set and Art-Net input is disabled, the PlayBack button becomes available.

**External Controls**

Use the [External Control](#) (listed under 'Recording Commands'): ARTNET\_RECORD.

With this control you can set any of the Art-Net recording parameters. Use Recording Mode to change whether you're recording, playing back or neither. Note, you will need to ensure you are in the correct Art-Net input/output mode, See ARTNET external control (listed under 'Media Commands').

*Example:*

```
artnet_record StartChan=1 EndChan=13 Universe=3 Subnet=2 ByteRange=2 InputIP=192.168.71.10  
InputIPSubnet=255.255.255.0 NumberFramesToRecord=80 SaveFile=C:\Movies\Record\art_test.txt  
PlayBackFile=C:\Movies\Record\artnetrec.txt RecordingMode=Idle LoopPlayback=true
```

**Note:** Save and PlayBack files are .txt files.

## Audio Equalisation

Access the global audio equalisation from GUI menu *View > Global EQ Levels*. This dialog shows controls which can shape the frequency response of the audio output.



### Equalisation

Vertical sliders affect the 15 frequency bands shown above, from this area you can change the mix of bass or high frequencies affecting the overall sound of the audio.

Press Reset to set back to a flat equalisation (no effect on audio).

### Low Pass Filter

A low pass filter, if enabled, allows all frequencies up to the Upper Frequency set using the slider. After this value, the volume smoothly reduces. Use this slider to remove unwanted high frequency sound.

Press Reset to allow all frequencies (no effect on audio).

## High Pass Filter

A high pass filter, if enabled, allows all frequencies from the Lower Frequency set using the slider. Before this value, the volume smoothly reduces. Use this slider to remove unwanted low frequency sound.

Press Reset to allow all frequencies (no effect on audio).

## Overall Volume

This is the same overall volume slider as in the main frame toolbar or Sequence Editor.

## Output Level Visualisation

To see a visualisation of the audio levels for each channel on the playback window, turn on the VU meter (Main Toolbar) while the audio is playing and enable one of the above areas.

Audio equalisation is stored in the show XML file.

## Part 3: DeltaOffline

## Part 3: DeltaOffline

---

DeltaOffline is a licence-limited mode of the full DeltaServer and DeltaGUI software, designed for use by show creators on a PC rather than a Delta Media Server. Without the demands for storage and playback performance, the user can access all the facilities of the Delta software to create and save shows, sequences and controls.

- Access to DeltaOffline, licences and training resources can be obtained on request from: [info@7thSense.one](mailto:info@7thSense.one).

Anything created in DeltaOffline can be played back without limitations on a full Delta licence with Delta Media Servers. Similarly, anything created in the full licence can be loaded and edited in DeltaOffline.



## Installing DeltaOffline

---

Since DeltaServer and DeltaGUI are pre-installed, users will not normally need to run a Delta installation themselves. DeltaOffline, however, will need to be installed on a separate PC. This licence (software, or possible a licence dongle key) only allows the Delta software to operate as DeltaOffline.

Run the 'Delta[version] x64 Setup.exe' file:

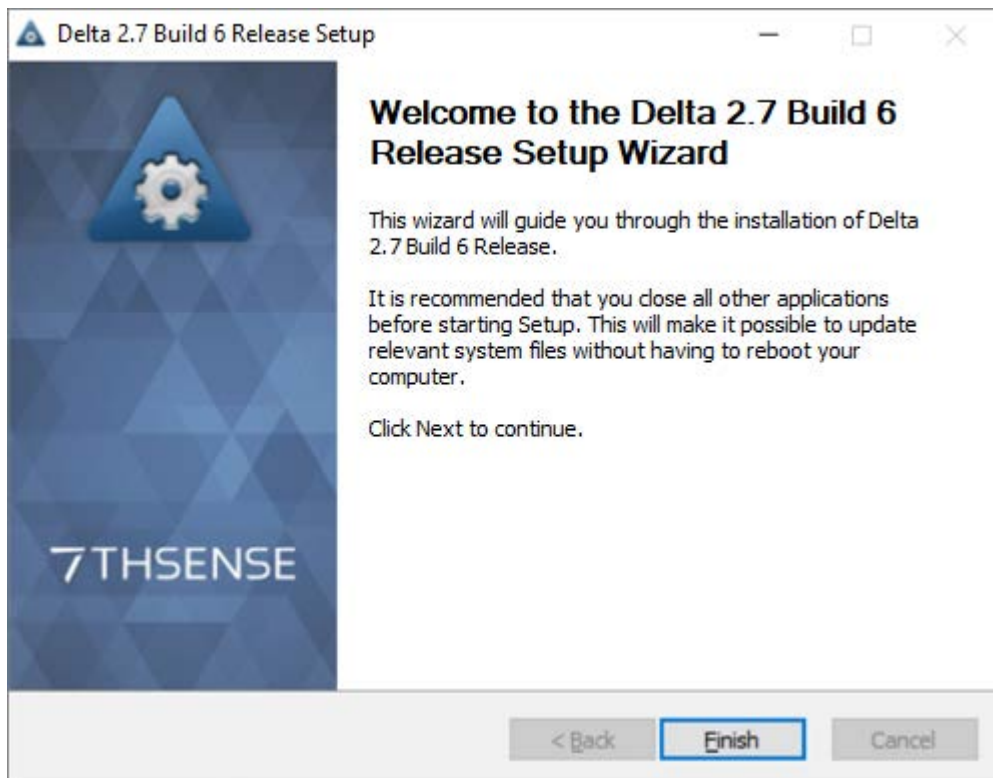

Agree to the terms and install both DeltaGUI and DeltaServer:

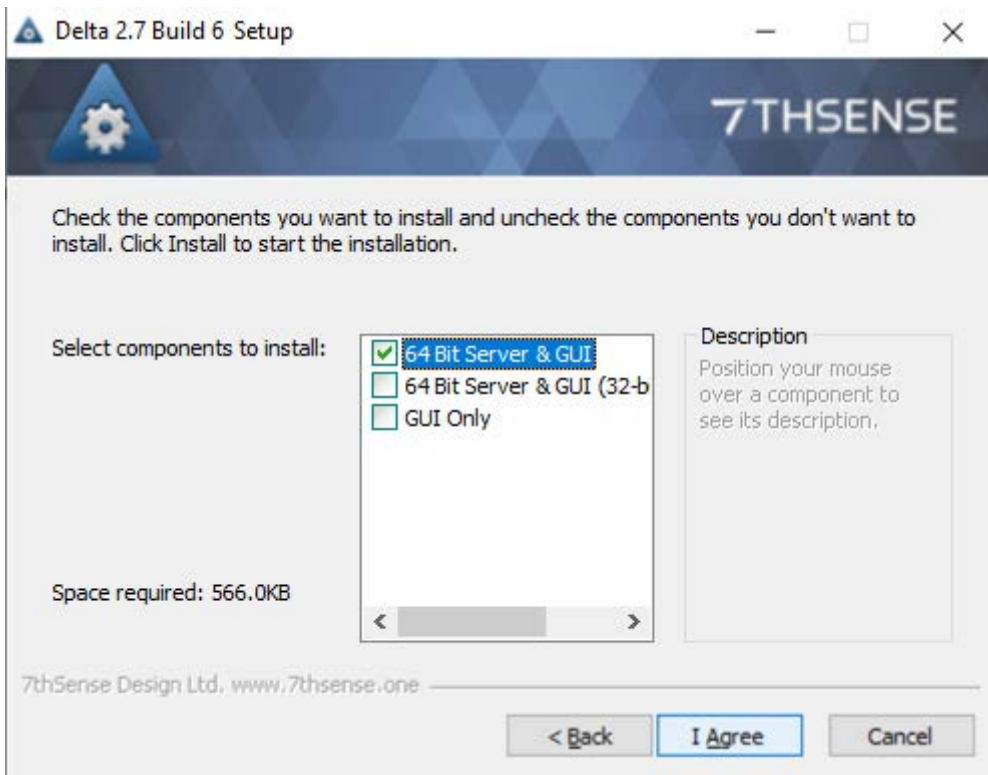

The install wizard will finish with the choice to run the software, so if your licence is a USB dongle key, first ensure you have plugged it into your PC. At this stage DeltaServer will prompt you to enter a digital license key.



Choose 'Configure as a standalone program' and enter the provided licence key.

- Allow licensing to access the Internet to check/activate licence > OK
- Product Registration > Provide valid Company and Contact name.

There needs to be Windows firewall clearance to run both DeltaServer and DeltaGUI.

The installation will drop shortcut icons onto your Desktop to open DeltaServer and DeltaGUI.

## Running DeltaOffline

Launch Delta from a PC, and click OK to open DeltaServer and its Playback window:

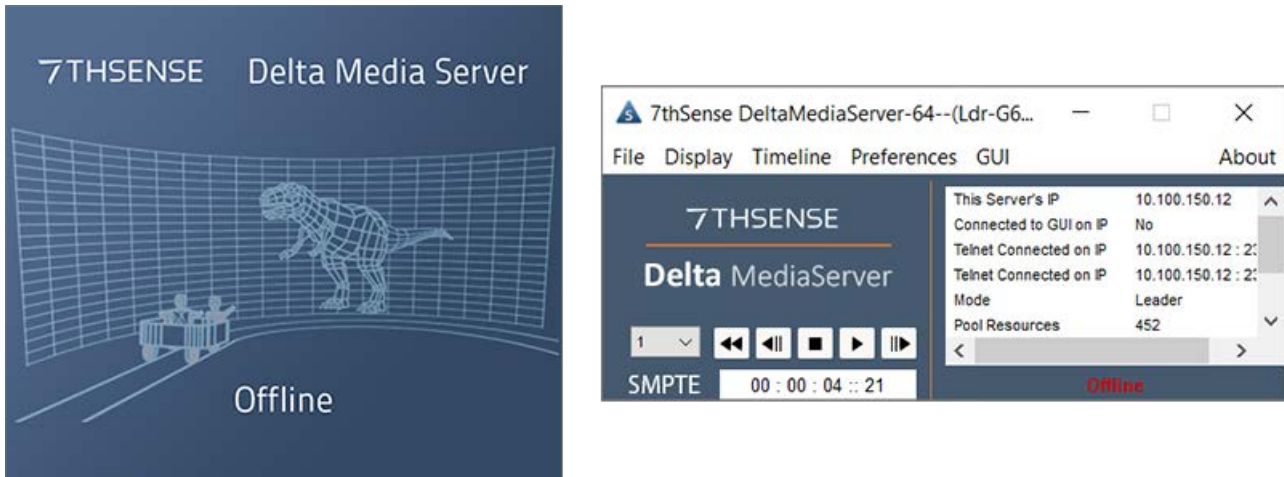

Press F to take back the Playback window out of full-screen mode. You will see a floating watermark in random positions and colours, per channel, over any media (or black if the current timeline is empty). This example shows media over 3 channels:

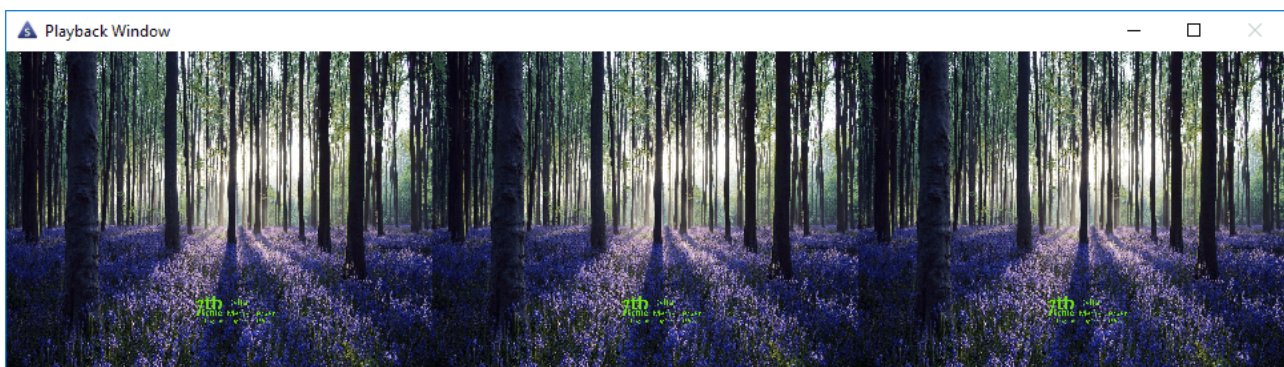

Preview (DeltaGUI, click Preview) or via Delta Web Service, will not show the watermark:

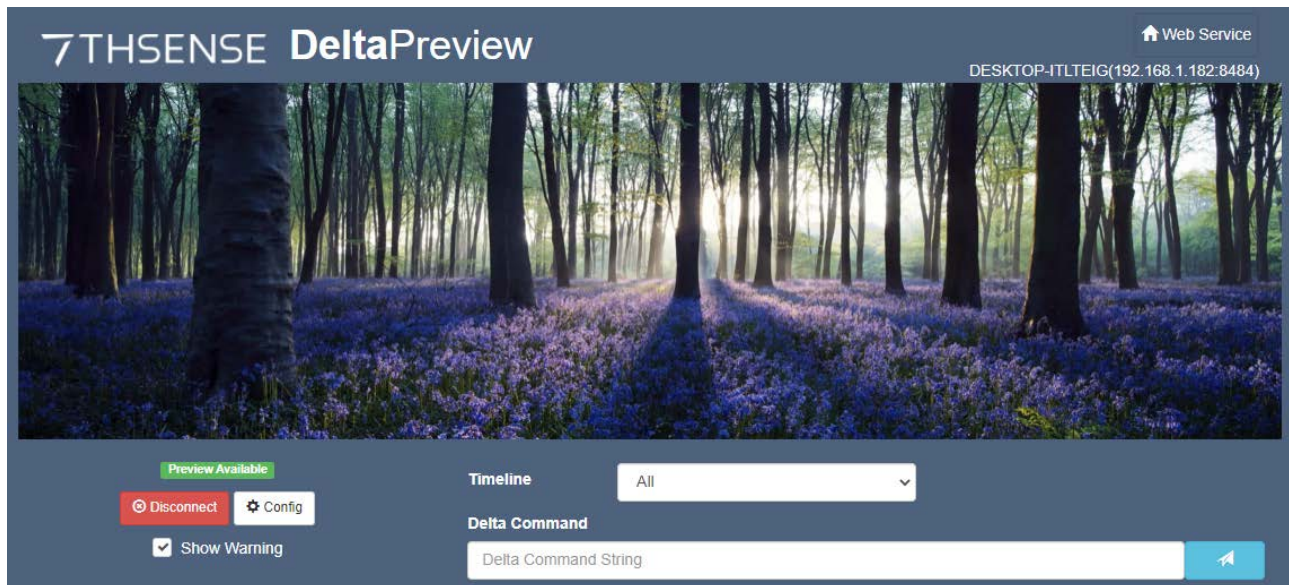

## Limitations and Use

The DeltaOffline licence allows you to build, load and save shows exactly as you would with a full licence, but playback is limited.

Every 30 seconds, the timeline clock will automatically stop any media playing, and the watermark will include 'Playback Stopped'. If in full-screen mode, the playback window will restore to previous normal size.

SDI output and high bit-depth are not supported.

# Appendices

## Appendices

---

There may be aspects of using Delta that can better be found in our other guides. Please refer to our online support portal at <https://portal.7thsense.one/online-help/> for all aspects of using, maintaining and developing your installations.

- [Appendix A: External Control](#) <sup>439</sup>
- [Appendix B: Licensing the Server](#) <sup>445</sup>
- [Appendix C: SDI Output option](#) <sup>447</sup>
- [Appendix D: SMPTE/Transport Control Setup](#) <sup>449</sup>
- [Appendix E: Shortcut Keys](#) <sup>453</sup>
- [Appendix F: Command Line Switches](#) <sup>455</sup>
- [Appendix G: Troubleshooting](#) <sup>456</sup>
- [Appendix H: Windows 10 Unified Write Filter](#) <sup>464</sup>
- [Appendix I: Express Mode, Creating Shows Programmatically](#) <sup>467</sup>

## Appendix A: External Control

---

Delta Media Servers can be controlled remotely using external controls to and from DeltaServer using serial or IP-based controllers. This includes serial (RS-232/422/485) as well as TCP and UDP.

In addition, [Delta web service](#) has a fully-featured HTTP API for interacting with servers over a local network.

➤ [External Control Commands](#) <sup>439</sup>

### Full External / Sequence Control

DeltaGUI menu, Help > External Control provides this complete list of Delta sequence and external control commands:

➤ [Vs2.0 External / Sequence Control Protocol](#)

New controls are added on a regular basis, but do not work retrospectively, so always refer to your installed Help from your DeltaServer.

## External Control Commands

---

### Notes on the External Controls help page

- Commands are not case sensitive, and individual commands are activated by Carriage Return (Hex 0D, decimal 13)
- If paths are used the character \ must be escaped with a second \, e.g.: path="Images\  
\foldername".
- To specify a timeline for a command, add TL=X in the command, X=Timeline number or R for Reserve timeline.
- If you have named the timelines, you can also use TL=myname (note that timeline naming enforces unique names)
- Some commands (**marked !**) : are non-realtime which could interrupt playback if playing, or will stop playback as part of the command.
- Non-realtime commands (**marked with an additional \***) : if Seamless Loop mode is enabled will not interrupt playback.
- Non Sequence commands (**marked E**) : Some commands are external control commands only, not sequence commands .
- Sequence Only commands (**marked S**) : Some commands are sequence commands only, not external control commands .

- Optional parameters or choices between parameters are enclosed in [].

For the complete list available to **your version of Delta**, go to DeltaGUI menu, *Help > External Control*.

➤ To see the [latest Help file online](#) go here.

Delta Media Servers can be controlled remotely using external controls to and from DeltaServer using serial or IP-based controllers.

This is a set of built-in English-language commands, allowing an external controller to control the timeline. You can also add custom events to the timeline which output strings on the external control COM port / Telnet port.

To specify a timeline for a command, add TL=X where X is the timeline in the range 1-32 or use R to specify the Reserve timeline. You can also use TL=ALL to specify all timelines.

In addition, by using *View > Timeline Names*, you can give a unique name to each timeline, this shows in DeltaGUI and you can also use TL=myname to address a specific timeline.

**Note: File names or marker names must be enclosed in double quotes if there is a space in the name.**

Some commands only work with a Leader server, since Follower units receive these commands from the Leader:

PLAY	Play the show (instant start if cue already done)
CUE	Cue the show and wait for the Play command
STOP	Stop the show
ADVANCE n	Step forward n frames
STEPBACK n	Step back n frames
REWIND	Rewind the show to frame zero
RATE n	Set the framerate to n frames per second
RATESCALE factor	Change the rate of the timeline by a multiple (1.3, 0.75 etc.)
LOADALL "file name"	Load the filename on all servers
MERGEALL "file name"	Merge the filename on all servers
SEQUENCEALL sequencename	Run the sequence on all servers



<b>LAYERFADEALL</b> [layer /name] opacity	Set the transparency of this layer/resource
<b>DISPLAYALL</b> [fullscreen/windowed/minimized]	Set all server's playback windows
<b>GOTOMARKER</b> "marker name" [play]	Move to a named marker on timeline, and optionally start playing from there.
<b>GOTOFRAME</b> framenummer [play]	Move to the framenummer specified and optionally start playing from there
<b>GOTOTIME</b> timecode framerate [play]	Move to a timecode at a specific framerate, optionally play. So "Gototime 0:1:0:15 30.00" will move to 1hour and 15 frames for a framerate of 30 fps, if your timeline is set to 24 fps, the same command will move to 1 hour and 12 frames (12 frames is 50% of 24 fps).
<b>MARKERSEARCH</b> direction=[next / previous] play=[true / false]	Stop, search for the next or previous marker in the timeline, move to that marker and optionally play
<b>CLIPSEARCH</b> clip=[next / previous] [play=true/false] [currentstart=true/false]	Search for the start of the next or previous clip (any visual resource such as movies, images, videocapture), optionally play immediately  if currentstart is true, it will find the start frame of the current visual resource. By default, currentstart is false, meaning it will find the start of the clip prior to the visual resource which is currently in scope and also loop round to the first or last resource.

**Please note:** From 2020 7thSense deprecated the terms master and slave for the dependencies between devices. We now refer throughout to 'Leader' and 'Follower' in our products.

To maintain functionality, both terminologies continue to work internally, but our documentation no longer uses the former terms. Users of pre-2020 products will need to observe the equivalence and continue to use the previous legacy terms.

## Return Codes

When first connected to Delta, External Control returns a statement such as:

```
ApplicationName Deltaserver.exe↵
Welcome to the 7thSense Delta Telnet interface, Help[CR] for commands↵
SERVER: ServerNode1↵
READY↵
```

Where ↵ is the 0x0d 0x0a Carriage Return / Linefeed Pair

Note the **SERVER** name is taken from the PC.

If a command is not recognised by Delta, it will return:

```
BAD↵
```

If a command is identified (no checks are run on parameters), it will return:

```
OK↵
```

Certain commands return more information:

**STATUS will return a string such as this:**

```
SERVER : ServerNode1 (Leader)↵
FILE : stratosphere show1.xml↵
MODE : Stopped↵
CURRENTFRAME: 2646↵
FRAMERATE: 30.0↵
LICENCE : Permanent↵
MOVIEDRIVES: C E↵
OTHERDRIVE: C↵
GRAPHICS: 1920 X 1080 60 HZ↵
SMPTE : OFF↵
AUDIOLEVEL: 100↵
VIDEOLEVEL: 100↵
↵
OK↵
```

In this return information:

The SERVER is taken from the PC, and will be (Leader) or (Follower)

The FILE is the current loaded filename

The MODE can be Stopped, Preparing to Play or Playing

The CURRENTFRAME is the current frame number

The FRAMERATE is the current framerate

The LICENCE can be Permanent or will show a date for time expired licences

LOAD "file" will return the STATUS information after the load

**LISTSHOWS [path] will return a list of XML files in the path specified such as:**

```
Show List ↵
08newsting.xml ↵
08newsting.xml.xml ↵
showcase 2006 novidcap.xml ↵
HD Test 1.xml ↵
tile 2006 hd3.xml ↵
OK ↵
```

**LISTMARKERS**

```
Marker List ↵
Start: 5 ↵
Images: 420 ↵
Movies: 780 ↵
Audio: 1382 ↵
```

Video Capture: 1980 ↵  
Text: 1680 ↵  
Crossfades: 2280 ↵  
OK ↵

## Example Dialog

```
ApplicationName Deltaserver.exe
Welcome to the 7thSense Delta Telnet interface, Help [CR] for commands
SERVER: athlon2600
READY
```

### **status**↵

```
SERVER : Server1 (Leader)
FILE   : ball bounce.xml
MODE   : Stopped
CURRENTFRAME: 311
FRAMERATE: 25.0
LICENCE : Permanent
MOVIEDRIVES: C C C C
OTHERDRIVE: C
GRAPHICS: 1920 X 1080 60 HZ
SMPTE  : OFF
AUDIOLEVEL: 100
VIDEOLEVEL: 100
OK
```

### **listshows**↵

```
Show List
08newsting.xml
test.xml
test2.xml
TILE.xml
OK
```

### **load "TILE.xml"**↵

```
SERVER : athlon2600 (Leader)
FILE   : TILE.xml
MODE   : Stopped
CURRENTFRAME: 0
FRAMERATE: 25.0
LICENCE : 30.12.2006
MOVIEDRIVES: C E V W
OTHERDRIVES: C
OK
```

### **play**↵

```
OK
```

**status** ↵

```
SERVER : athlon2600 (Leader)
FILE : test.xml
MODE : Playing
CURRENTFRAME: 22
FRAMERATE: 37.5
LICENCE : 30.12.2006
MOVIEDRIVES: C E V W
OTHERDRIVES: C
OK
```

**stop** ↵

OK

## Troubleshooting External Control

To see what communication is taking place from your control system to the server, on the DeltaServer dialog, see *About > External Control Traffic*:

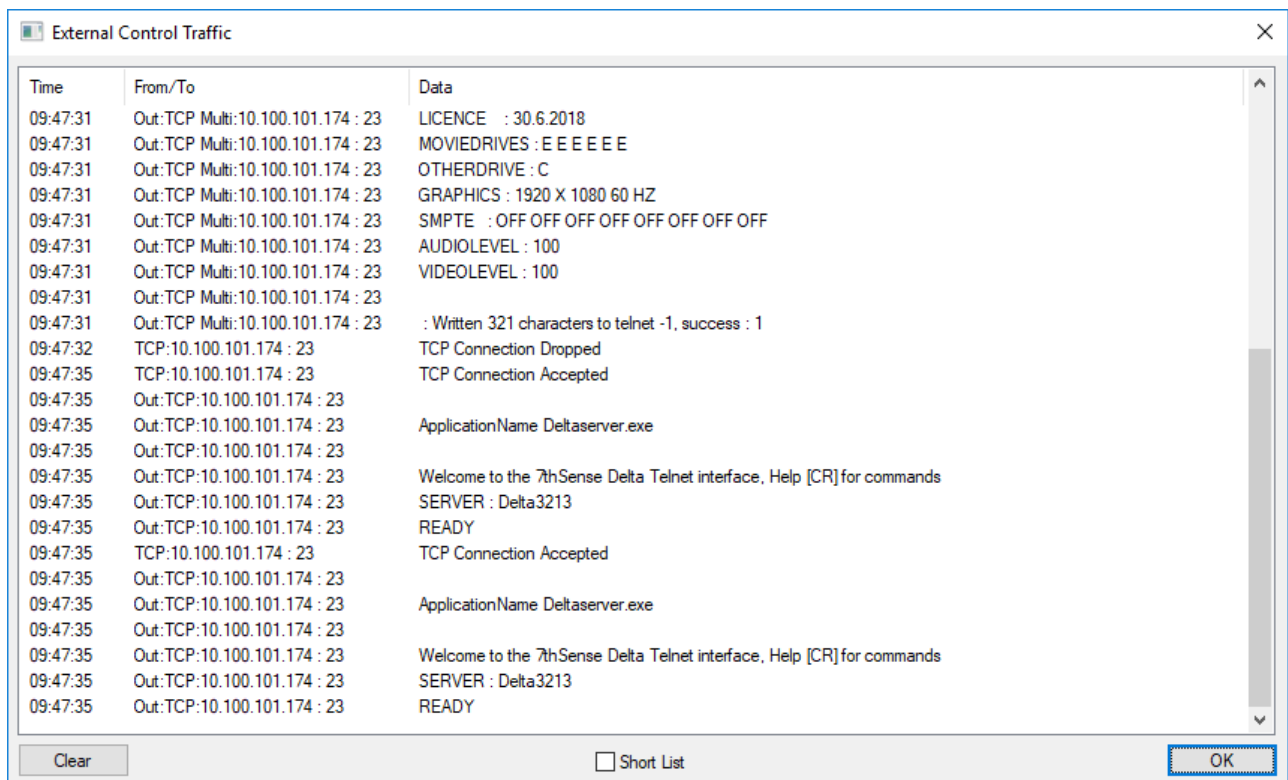

By default, this dialog shows the last 2000 lines of communication (both input & output), if you enable the Short List checkbox, only the last 200 lines are retained, which speeds up display.

## Appendix B: Licensing the Server

Delta is licensed software, using a physical USB Key or disk based licence, which is locked to the physical hardware of the Delta PC. This Key is supplied by 7thSense.

To license a Delta PC (if not already done by 7thSense):

- Install Delta using the setup.exe supplied
- Insert the USB Delta Key into USB port.

### Microsoft Windows

- Run the setupdrv.exe supplied for Blue dongles.
- Install the dongle in a USB port – the driver should be found automatically.

An unlicensed Delta system will continue to run, but certain features are disabled, and you won't be able to save a Delta file.

**Note** that DeltaGUI does not require a license, only the server, so you can run DeltaGUI from any PC.

### Updating a 7thSense Licence

An update code can be obtained from 7thSense to add features remotely through email.

To update the USB licence, from the **DeltaServer** dialog menu, choose *About > Update Licence*:

Enter Change Code

Dongle 3950306873 Update Number 2

Change Code

0e 12 6b 73 98 22

Make Changes

Done

The emailed code should be copied into the Change Code edit box and then press [Make Changes] – any errors will be shown below.

**Note** that to obtain an update code, you will need to send the Dongle Number and Update Number to 7thSense – these are shown above or in the About > About Server dialog.

## Integrator / Reseller Licensing

If your integrator or reseller has provided your licence, they may have employed an additional service regarding licence expiry. In this case, they will email you a code that must be ingested using the **DeltaGUI** main menu > *Wizards* > *Ingest User Licence*:

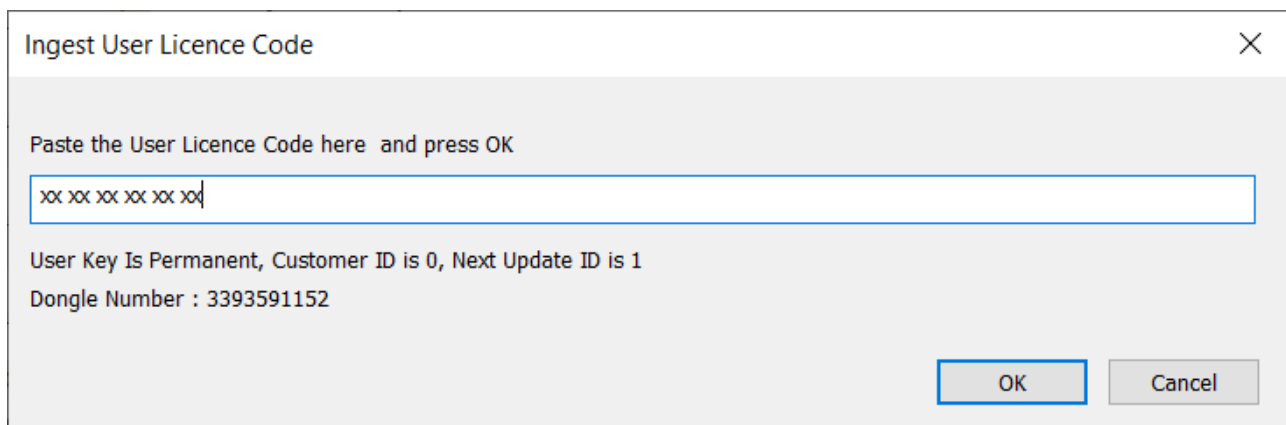

Ingest User Licence Code

Paste the User Licence Code here and press OK

xx xx xx xx xx xx

User Key Is Permanent, Customer ID is 0, Next Update ID is 1  
Dongle Number : 3393591152

OK Cancel

## Appendix C: SDI Output option

Delta can be configured as having SDI outputs instead of DisplayPort, which is useful in certain AV installations having long video cable runs.

The SDI option has to be licensed and a compatible SDI output card (typically Matrox) installed.

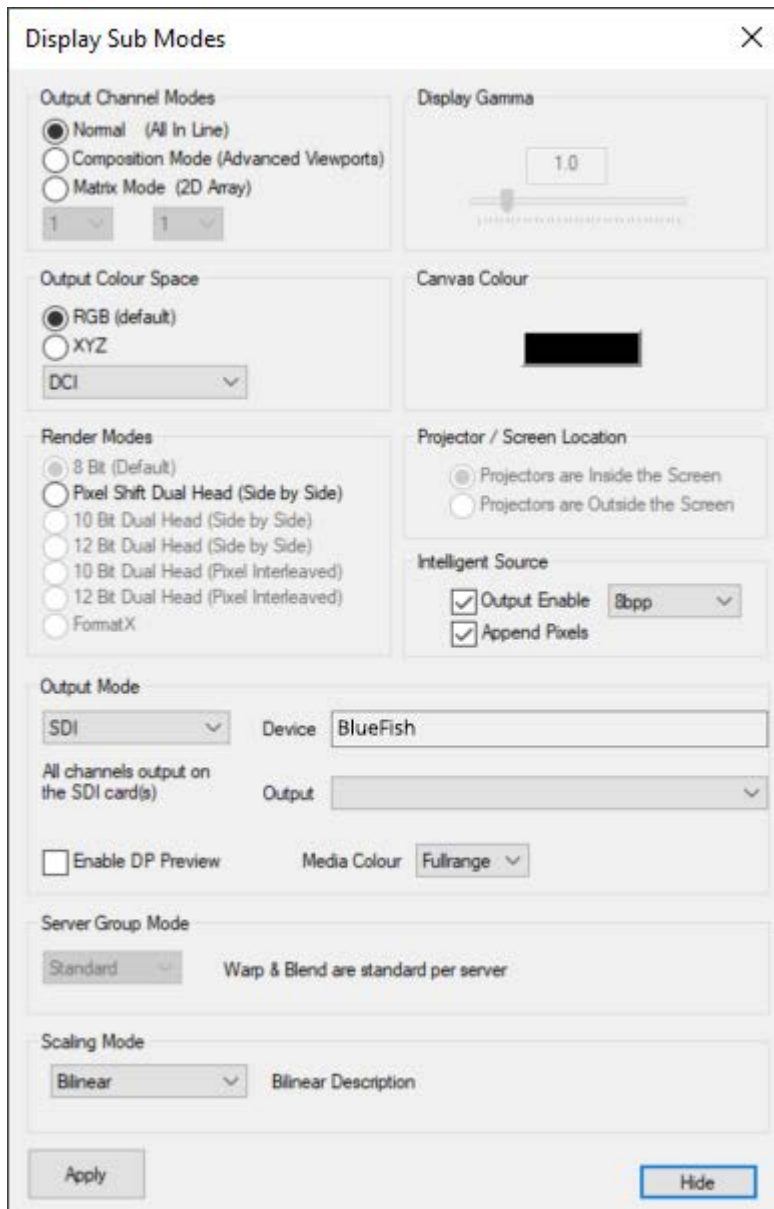

You can configure the output mode in *Config > Display*, Output button. In this dialog you can choose DisplayPort or SDI outputs. In SDI mode, you can select the various HD video formats which are stored in C:\program files\7thSense\Delta\System\SDI\_BF.XML. You can edit this XML file to add other video formats, which will work as long as the mode is supported by that specific SDI card.

**Enable DP Preview**

Enable this to also show all channels on the DisplayPort outputs. Note that these are preview only, and could show video tearing on the DisplayPort outputs in this mode.

**Media Colour****Rec709**

This is the HD standard in which certain colours are reserved and the media uses a restricted range of values (8-bit is 16 to 235, 10-bit is 64 to 940). Choose this if the media you have conforms to the Rec709 standard.

**Full Range**

Select this option if the media uses the full range of colours (0-255 in 8-bit, 0-1023 in 10-bit).

**Audio**

Note that for servers with Bluefish 4K Neutron cards, audio can be optionally made to stream via SDI (up to 8 channels). Please contact 7thSense Design for advice.

Once installed, in SDI mode, audio will always be streamed via SDI and not output on any other sound device.

**SDI Timing**

When in SDI mode, the timing is taken from the SDI card, so in DeltaGUI, *Config > Preferences > Timing*:

- Check or Uncheck the **LTC Control – Enabled** checkbox, according to the LTC / SMPTE chase mode you need.
- **Timing Mode** is 'Use hardware'
- **Framerate** is 'Custom' and type in the actual framerate you need (e.g. 23.976)
- Set **Automatic Framerate** to unchecked and select 'Custom', type in 23.976
- Set **Force Framerate** to unchecked



## Appendix D: SMPTE/Transport Control Setup

For Delta to listen to SMPTE LTC timecode (and play, stop, jog and shuttle from an external controller, accordingly) you must have one of the following:

1. An **LTC timecode device** that can generate SMPTE timecode (interfaced into Delta via Soundman, LTC Reader or Adrielec card).

**Note:** SoundMan and LTC Reader are listed as **Local LTC** in the dropdown menu. Adrielec would appear on the list separately if the card is detected.

or

2. A **Midi (MTC) device** (interfaced into Delta via suitable MIDI input port).

or

3. **RS422 Sony 9-pin D Serial Connector** (or RS232 connector with suitable cabling and adapter).

### Configure Delta for listening to an external 422 device

In DeltaGUI, click *Configure > Preferences > Timing*

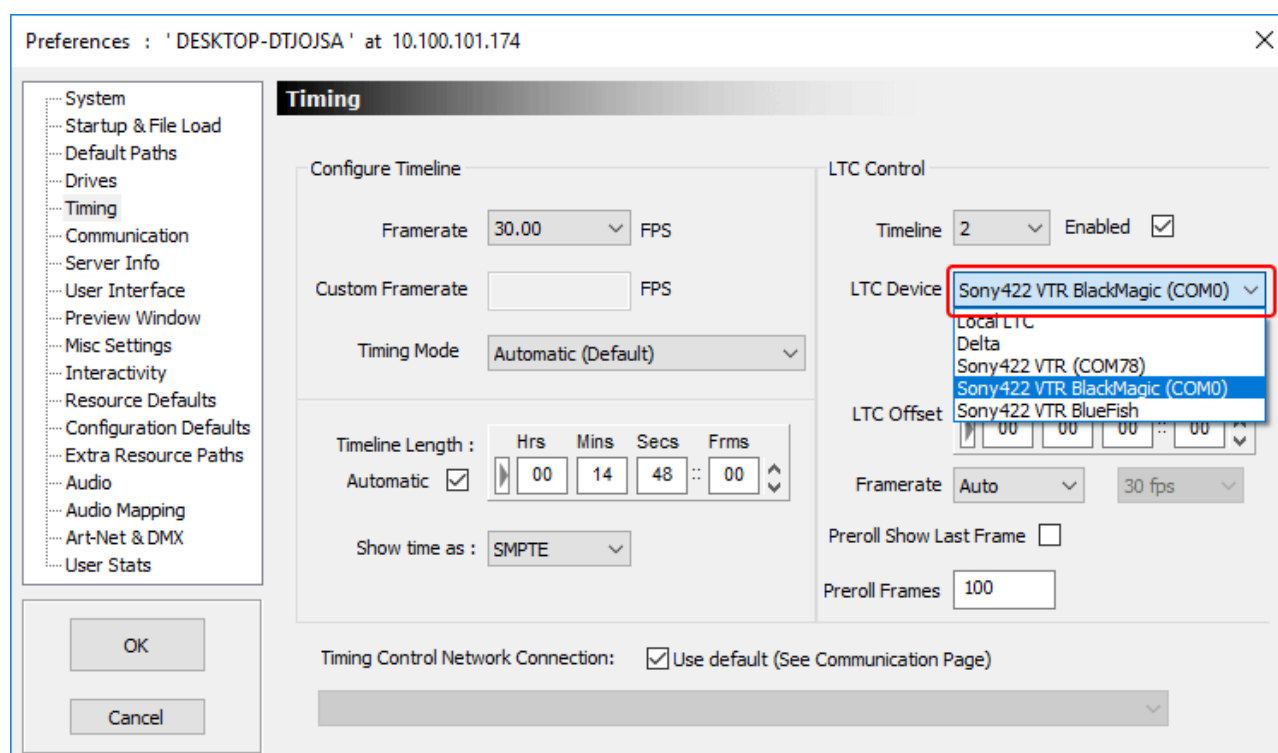

Tick the **Enabled** checkbox to enable the SMPTE tracking and select its correct device.

**Sony RS422**

Delta version 2.4 onwards has three new options (as above) to allow for Sony RS422 connections.

The connection for Sony 422 is a 9-pin D Serial Connector. Its COM port should be set in Device Manager to match that within Delta (which defaults to 78 in the registry).

**BlackMagic**

Blackmagic uses a DeckLink card which retrieves the COM port from the hardware automatically.

For Blackmagic cards, ensure that you get the correct cable and adapter as the physical pin-out for 4K Blackmagic cards in a Delta server may require a M/F adapter as they are set to be 'Controllers' – which is the same connection as required for the show control hardware itself. Older Blackmagic cards are set to be 'Followers' and so the standard controller-Follower cable should be correct.

**Bluefish SDI**

A Bluefish SDI card does not require the COM port to be set, as it is controlled internally.

Once a SMPTE device is selected, press the LTC button in the lower left area of DeltaGUI to allow the external controller to run the show. Note that the playback controls will disappear since, at this point, we are purely tracking the incoming timecode in DeltaGUI.

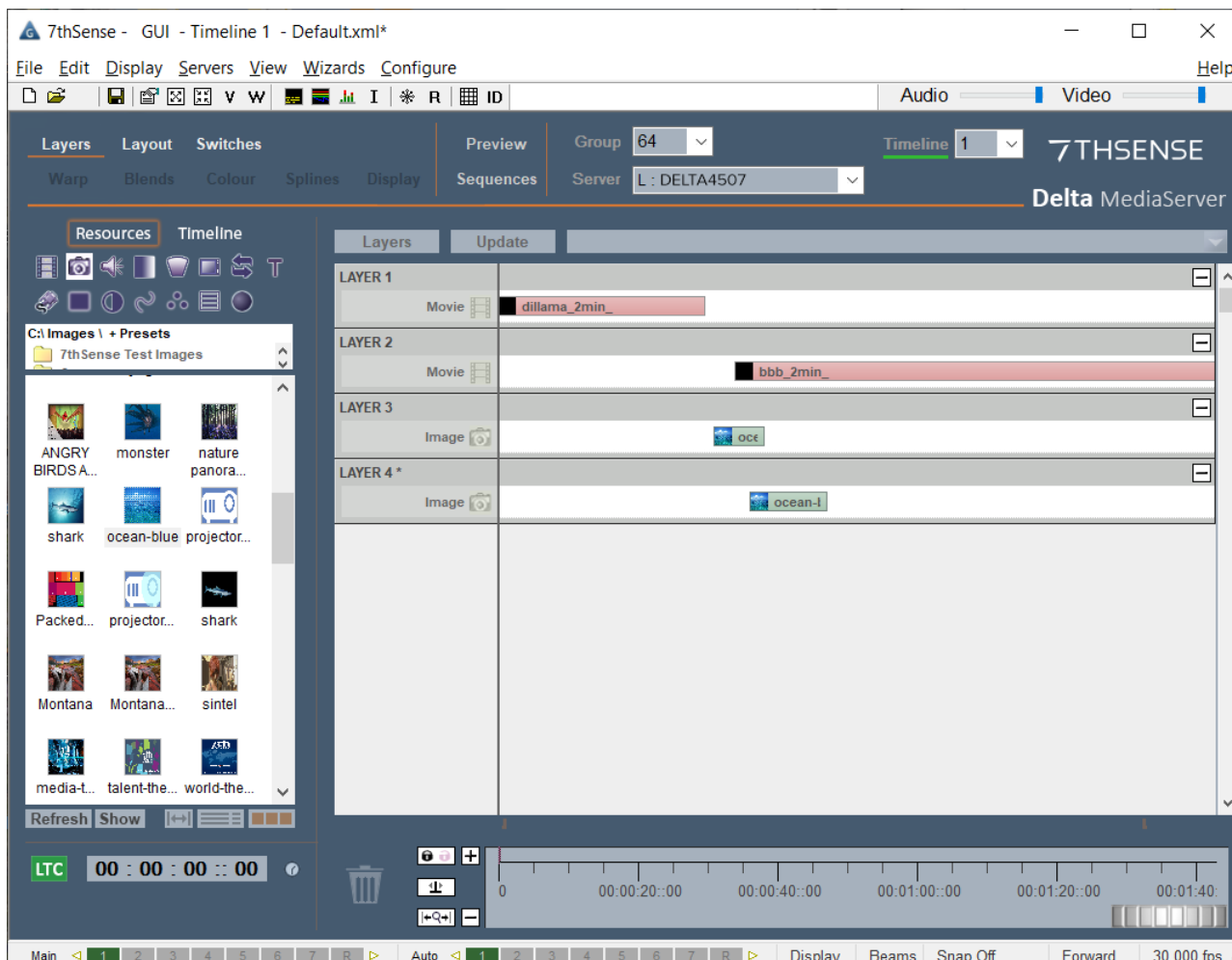

**Note:** In this case LTC Chase is ON for Timeline 1 but this is not automatically applied to any other timeline – click to select a timeline then click SMPTE ON/OFF as required for each.

## RS422 Transport Controls

(for outputting to an external LTC device)

In order for Delta to have some control over the external LTC device, configure a comport to have the following parameters in *Configure > Preferences > Communication*:

COM: 38400, Odd Parity, 8 Data bits, 1 Stop bit, set to Transport Control

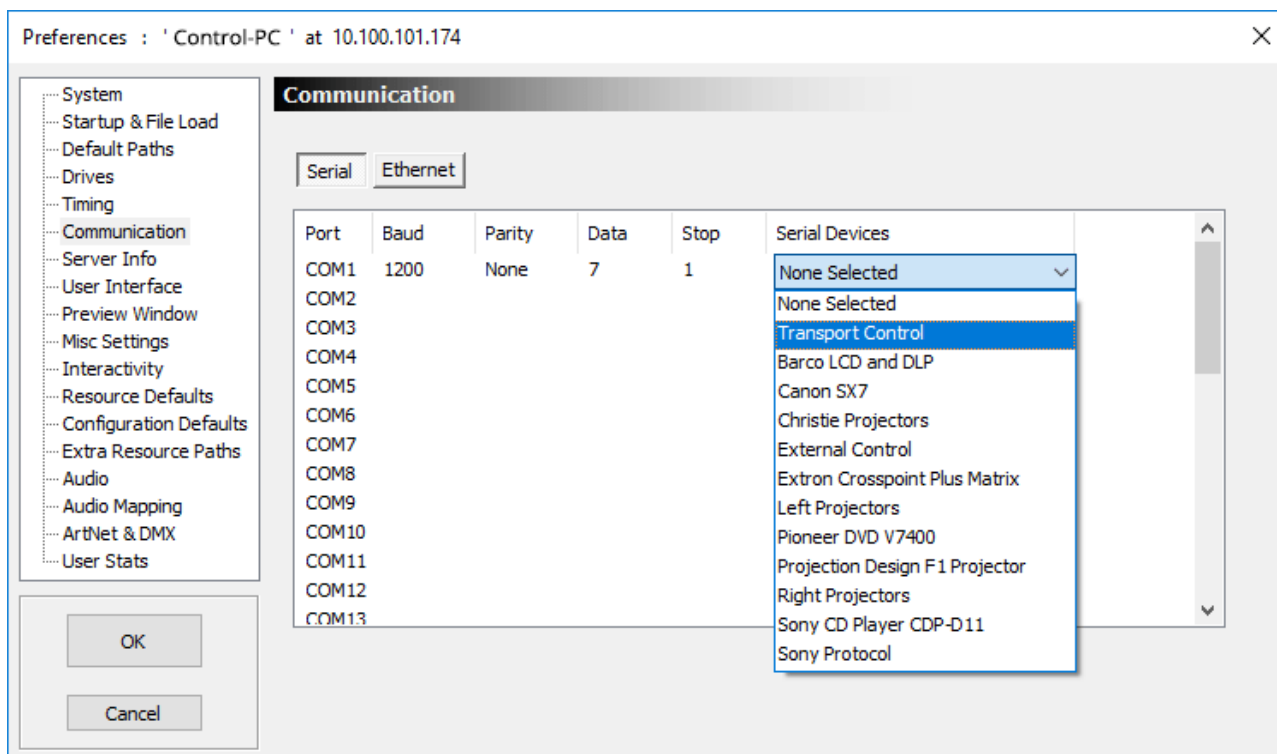

Connect this COM port to the external LTC device input via an RS422 converter like this:

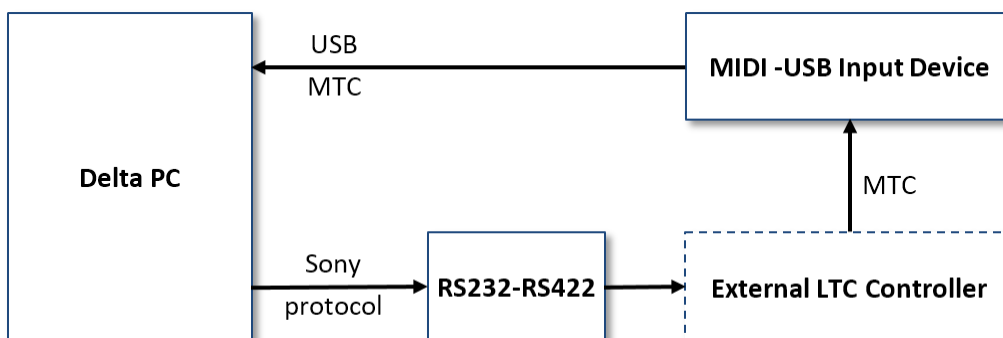

Now, when you enable SMPTE tracking by pressing the DeltaGUI SMPTE button, the transport controls remain, and when you play, stop / drag the slider, you are communicating to the external LTC controller via Sony Protocol commands.

### Example Devices

**RS232 – RS422** Moxa™; Transio TCC-100; Sony™

**MTC Input** M-Audio™; MidiMan

**External LTC Device** CB Electronics™; P2MMC

**Adrielec** PCIe-TC LTC Reader card

## Appendix E: Shortcut Keys

---

The main menu can be navigated by Alt+ keys, for example Alt+V+M for the markers list, or Alt+C+T for TCP connections.

The following are also listed in DeltaServer: *About > Shortcut Keys*, and DeltaGUI: *Help > Shortcut Keys*.

### Common to both GUI and Server

<b>P</b>	Play
<b>H</b>	Halt the playback
<b>R</b>	Stop and rewind the timeline to frame 0.
<b>F1 – F12</b>	Control+F1 – F12
<b>Shift+F1 – F12</b>	Control+Shift+F1 – F12
<b>0 – 9</b>	Control+0 – 9
<b>Shift+0 – 9</b>	Control+Shift+0 – 9

A marker on the timeline can be set to one of the function keys or numeric keys for quick access to a timeline position. Using the Control or Shift keys, up to 88 markers can be accessed by a key.

<b>Home</b>	Rewind to frame 0
<b>Left Arrow</b>	Step back one frame
<b>Right Arrow</b>	Step forward one frame
<b>Ctrl+Left Arrow</b>	Search previous marker
<b>Ctrl+Right Arrow</b>	Search next marker
<b>Ctrl+Shift Left Arrow</b>	Move the current timeline to the start of the previous movie
<b>Ctrl+Shift Right Arrow</b>	Move the current timeline to the start of the next movie
<b>Alt+F1</b>	Help file

### Server Playback Window

<b>F</b>	Toggle the playback window fullscreen or windowed
<b>S</b>	Show playback statistics
<b>Q</b>	Reset statistics display
<b>G</b>	Show the graph

<b>A</b>	Show the Audio levels
<b>Shift+arrows</b>	Position the playback statistics on screen
<b>Ctrl+arrows</b>	Size the width and height of the playback statistics block (and type size)
<b>Ctrl+Shift+arrows</b>	Position the graph block
<b>Ctrl+Shift+Q/W</b>	Make graph block narrower/wider
<b>Ctrl+Shift+Y/H</b>	Make graph block taller/shorter

## GUI

<b>Space</b>	Toggle playing
<b>Ctrl+G</b>	Goto Dialog
<b>Ctrl+C</b>	Copy
<b>Ctrl+X</b>	Cut
<b>Ctrl+P</b>	Paste
<b>Ctrl+B</b>	Paste At
<b>Ctrl+A</b>	Select all
<b>Ctrl+D</b>	Deselect all
<b>Del</b>	Delete all selected
<b>Ctrl+R</b>	Reserve Mode toggle
<b>Ctrl+M</b>	Add Marker at current frame
<b>Ctrl+F</b>	Find a resource
<b>Ctrl+Q</b>	Toggle Resource Pool Width
<b>Ctrl+T</b>	Show the Timelines dialog
<b>+ / - or [ / ]</b>	Zoom in or out on the timeline.
<b>Shift+Z</b>	Zoom to the extents of all media on the timeline
<b>Ctrl</b>	<i>when dragging a resource or selected resources: Copy.</i>
<b>Ctrl</b>	<i>when incrementing or decrementing a value: 10 × speed</i>
<b>Shift</b>	<i>when incrementing or decrementing a value: 1/10 × speed</i>

## Appendix F: Command Line Switches

---

Listed in DeltaServer and in DeltaGUI > *Help* > *Command Line Switches*.

These switches can be sent to the server application to modify its startup behaviour. Enter them in the Target box of a shortcut.

### DeltaServer (affects this run only)

- minimized            Show the server dialog and playback window minimized.
- minimizedialog    Show the server dialog minimized.
- fullscreen         Show the playback window fullscreen.
- delay n             Delay the server startup for n seconds
- nopool             Do not look for pool resources on disk at startup

### DeltaServer (changes also stored for next run)

- leader              Change the current mode to Leader
- follower            Change the current mode to Follower.
- group n             Change the current group to n
- smpte\_on            Enable tracking SMPTE
- smpte\_off           Disable tracking SMPTE

### DeltaGUI

- group N             Force DeltaGUI to accept only connections from group N
- selectgroup        Force DeltaGUI to show a dialog on start to select the single group to allow connections from.

**Note** that when starting DeltaGUI with no command line parameters, any other instance of DeltaGUI will be terminated on that PC. However, if you run with Group N or selectgroup command line parameters, this will not happen, so on the same PC you can have one DeltaGUI on Group 3 and another on Group 6 and so on.

## Appendix G: Troubleshooting

---

### DeltaGUI will not connect to the server

---

➤ See also [Communication Configuration](#) <sup>(102)</sup>

DeltaGUI automatically looks for all servers on the same network. If it cannot find the server, it could be one of the following:

#### Server does not have an IP Address

For DeltaGUI to find a server, the server must have a valid IP address. This happens when the Ethernet interface of the PC is connected to another Ethernet device such as a Hub or Switch. If the server IP address is 0.0.0.0, this indicates it does not have a valid IP Address.

**Corrective Action** – Connect the server to an Ethernet Hub or switch and attach the DeltaGUI PC to the same hub or switch. Check if a DHCP server is available or set the server to a static IP Address in the same range as the DeltaGUI PC.

#### Server has a different IP range to the DeltaGUI PC

If the server has an IP Address of 10.100.100.200 and a Netmask of 255.255.255.0, it could never be found from a DeltaGUI PC which is on 192.168.2.100, since they are on completely different IP ranges.

**Corrective Action** – Change the DeltaGUI PC, or the server's IP Address to the same range – e.g. DeltaGUI on 10.100.100.88, server on 10.100.100.200

#### DeltaGUI has blocked this group

You can type a list of groups into the DeltaGUI to which it will not connect. This list is held in the Preferences dialog, at *Configure > Preferences > Communication > [Ethernet], [Blocked Groups]*.

**Corrective Action** – Check the server's group is not listed in this edit box, if it is, remove it from this list and press OK.

#### Another DeltaGUI is connected

Only one instance of DeltaGUI can connect to a server at a time, if you have multiple groups, use the SelectGroup command line switch on DeltaGUI to force it only to look at this one group – in that way you can have multiple DeltaGUIs on a single PC connected to multiple servers (in different groups).



To understand which DeltaGUI is connected, minimise the playback window (F key) to find the server dialog (through VNC), then the status indication will highlight the IP address of the DeltaGUI machine. You can also choose *GUI > Kill GUI* from the DeltaServer dialog. Alternatively, send in the KILLGUI external control command to kill the currently attached DeltaGUI. Note that this is safe to do as the contents of the server, even if not saved, are not altered by the DeltaGUI terminating (though the person using the DeltaGUI may be surprised when it disappears).

## DeltaServer and DeltaGUI versions are mismatched

The version of DeltaServer and of DeltaGUI must match. Software version in each is found in *Help > About*.

## Can you ping the server's IP?

If you have confirmed that your IP addresses are setup in a workable manner, 'Ping' will confirm that you have network access to the DeltaServer. 'Ping' is a Windows Command Line command that sends an ICMP Echo Request command to another device on the IP network and awaits a response. Here is an example where a server known to exist at IP address 10.100.101.230 is sent a 'Ping' from a remote PC:

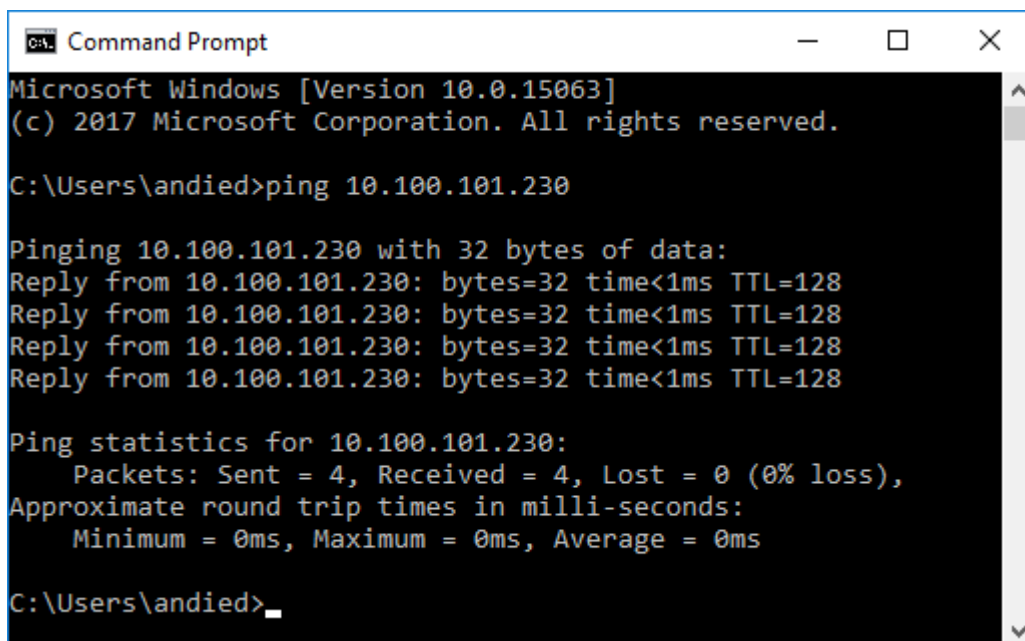

```
Command Prompt
Microsoft Windows [Version 10.0.15063]
(c) 2017 Microsoft Corporation. All rights reserved.

C:\Users\andied>ping 10.100.101.230

Pinging 10.100.101.230 with 32 bytes of data:
Reply from 10.100.101.230: bytes=32 time<1ms TTL=128
Reply from 10.100.101.230: bytes=32 time<1ms TTL=128
Reply from 10.100.101.230: bytes=32 time<1ms TTL=128
Reply from 10.100.101.230: bytes=32 time<1ms TTL=128

Ping statistics for 10.100.101.230:
    Packets: Sent = 4, Received = 4, Lost = 0 (0% loss),
    Approximate round trip times in milli-seconds:
        Minimum = 0ms, Maximum = 0ms, Average = 0ms

C:\Users\andied>
```

## Is there a firewall blocking communications on your DeltaGUI computer OR on DeltaServer itself?

From the factory, the proper Windows firewall exceptions should always be opened.

## Delta will not play smoothly

---

When playing movies, the playback is jerky or random, this could be one of the following:

### Server is playing movies from a disk that is not fast enough

Normally, Delta has a RAID or SSD drive for movie playback, if playing from the C: operating system disk, this may not be fast enough.

**Corrective Action** – Check the server is configured to use a fast enough movie disk (*Configure > Preferences > Drives*, check the Movie drive is RAID or SSD).

**Corrective Action** – Check the movie transfer disk rate by hovering over the movie on the DeltaGUI timeline, this shows it in MegaBytes/second. For example, a 8Mb/s movie may be ok on the C: drive, a 50Mb/s movie will need 2 disks in RAID0, a 180Mb/s movie will need SSDs or 8 disks in RAID5.

### Disks and graphics appear ok, but movie playback is not smooth

Check the playback window graph and playback statistics (press the G and S keys):

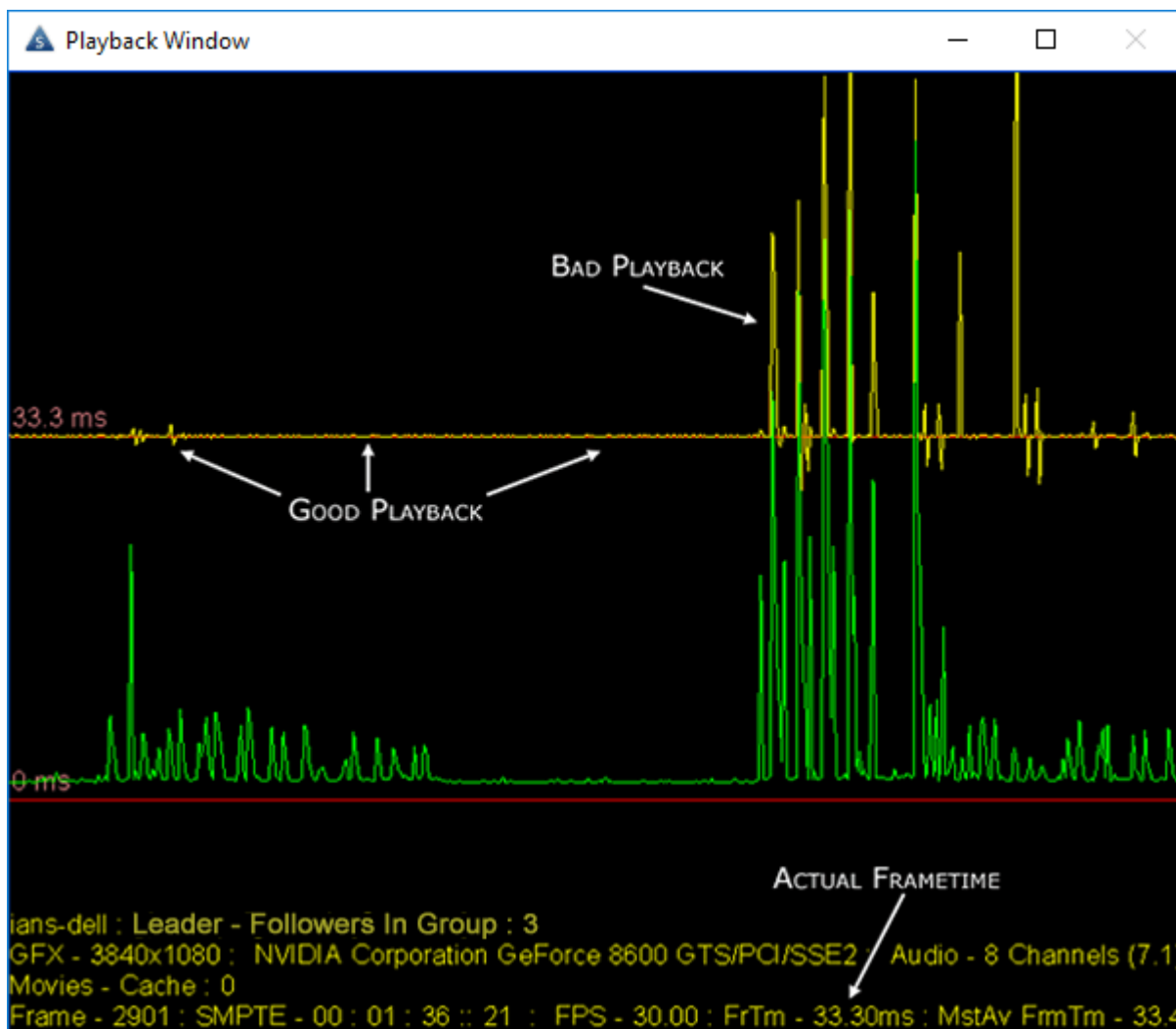

If the yellow line is on the top red line as in the left part, playback will be smooth, if there are yellow spikes in the graph well above the top red line, something is causing bad playback.

**Corrective Action** – Check there is not another application running which is taking high CPU time.

**Corrective Action** – Check the FrTm value (shown above) matches the expected frame time, e.g. 33.3ms for 30 fps, 40ms for 25 fps and 41.7ms for 24 fps. If this is not the case, check the EDID to projector or monitor matches the expected video format.

➤ See also [User Information / Stats](#) <sup>(125)</sup>

## System Diagnostic Logs

In the event of system malfunctions, diagnostic logs are a great assistance. The more 7thSense can access of the circumstances the better. We may ask you to send us DeltaServer logs, MiniDump log files, and Windows Event logs.

## System Logs

You can create a system log to send back to us using DeltaServer dialog's Save System Log option, found in the server dialog menu – *About > Save System Log*.

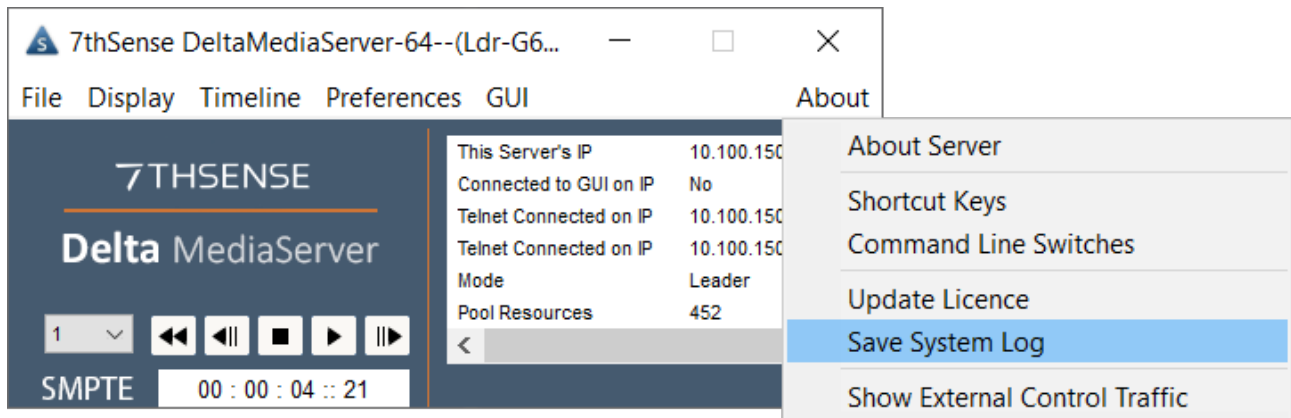

This creates a date and time-stamped folder by default into the **C:\program files\7thsense\Delta\Logs** folder.

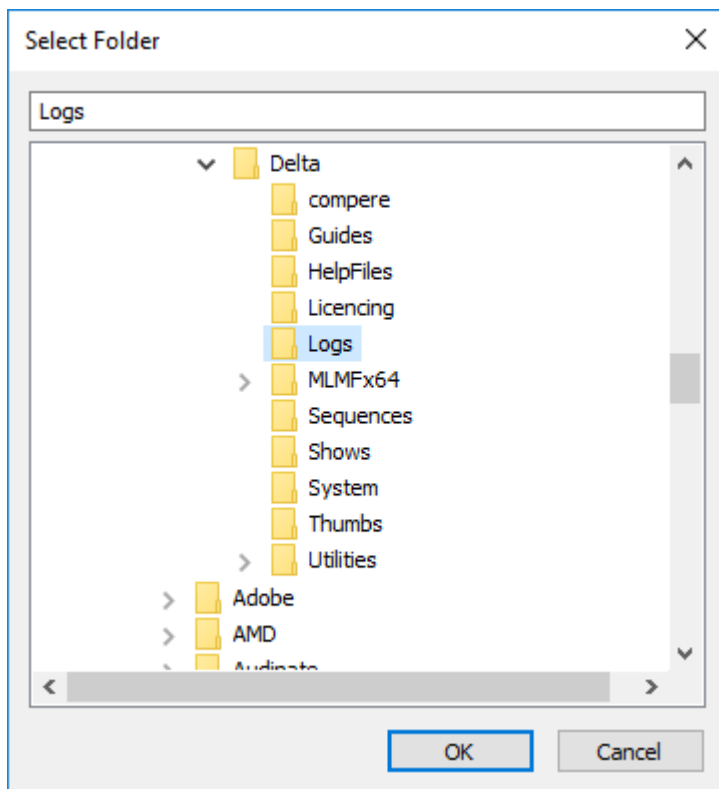

It contains these folders:

- \Logs
- \Sequences
- \Shows
- \System

and a copy of the 7thSense registry:

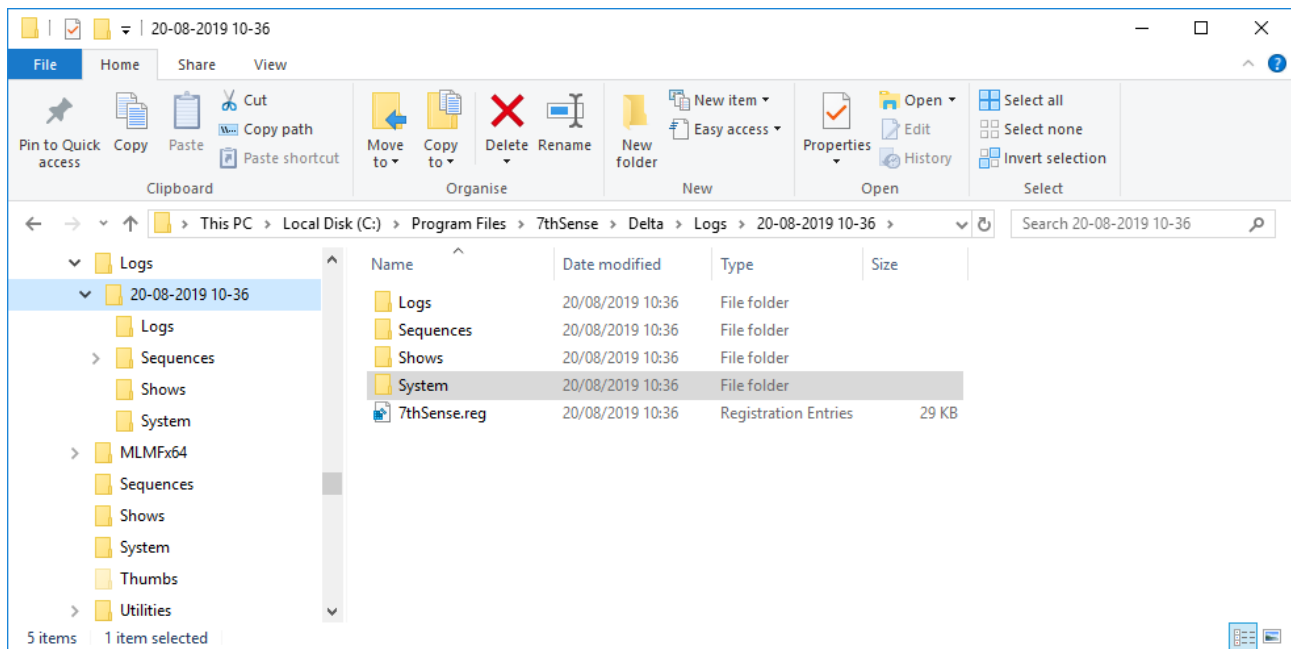

Zip this folder up and send it to 7thSense support if requested.

Delta from version 2.5 also produces a MiniDump file if the server crashes. Find any file beginning 'DeltaServer\_MiniDump~' in C:\program files\7thsense\Delta\Logs, and send that as well.

From any remote networked PC, you can access the logs from the IP address of the required server, for example:

\\10.100.101.56\7thSense\Delta\Logs

## Windows Event Logs

Use VNC to access a remote server (use connection password 7th), and search 'Event' from the Windows Search to access Event Viewer.

Find *Custom Views > Administrative Events* and right-click to select 'Save All Events in Custom View As...'

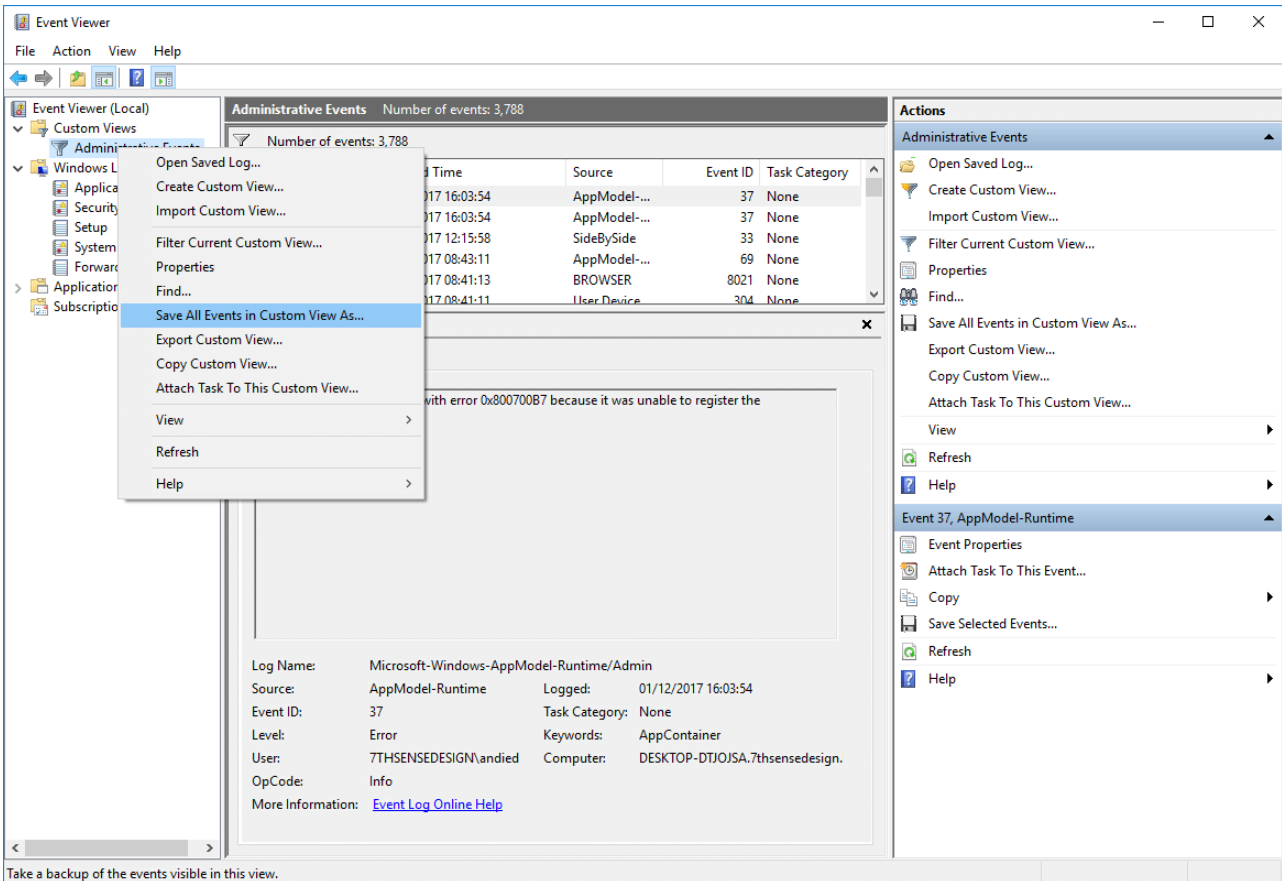

Save the Windows log file back into the Delta Logs folder (C:\program files\7thsense\Delta\Logs) as a .evtx file, and using default export settings if prompted.

This log may not have all the information we need. A more comprehensive set of logs may be required. If so, expand 'Windows logs' on the left, and export (right-click, 'Save all Events As...')the Application, Security, Setup and System logs separately:

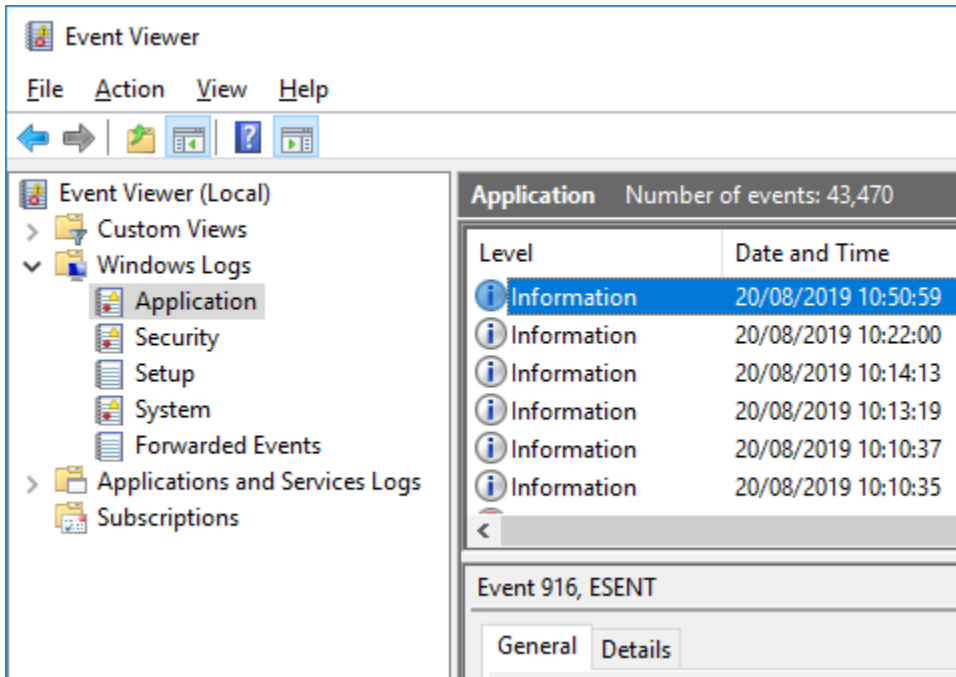

A suggested naming convention might use the server name and date as prefix and suffix:

Delta\*\*\*\* Application dd-mm-yy'  
 Delta\*\*\*\*Security Logs dd-mm-yy  
 etc.

## Appendix H: Windows 10 Unified Write Filter

---

Applies to servers running Windows 10 Enterprise and Delta 2.6 only, where the feature has been explicitly turned on in Windows.

Making use of the Unified Write Filter (UWF) enables protection of the server C:\ drive by locking write access. Whilst changes or additions can be made, they are written to a copy of the source on a virtual 'overlay'. This means that any changes at all made to any files on the C:\ drive, will be lost on reboot. There are several warnings and indicators in DeltaGUI when the feature is enabled, including greyed-out Save menu items, so that intended development work is not made only to be lost. External drives are not locked.

When this Windows feature has been enabled on a Delta server, it is controlled using the Delta external control command SETUWF. This interacts with the Windows UWFMgr app.

### When UFW is Implemented

Since it is important not to create a show or make changes that cannot be saved, the UFW 'locked' status is apparent in the DeltaGUI menus and title bar.

- In DeltaGUI any menus involving changes will be greyed out, and the resource pool will display a warning:



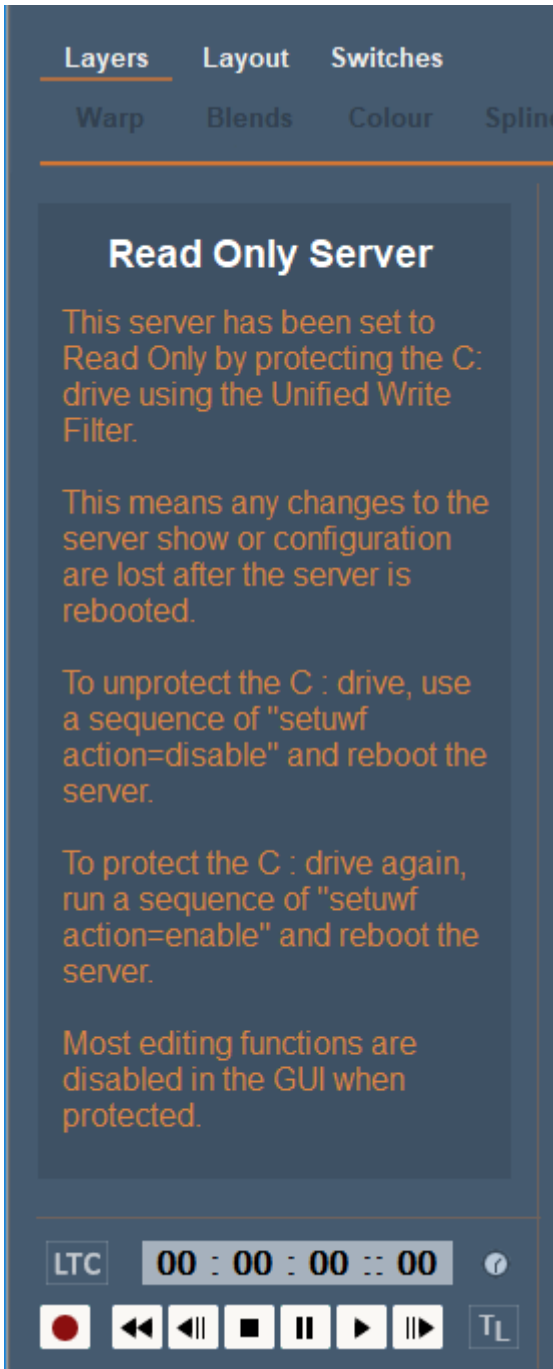

- The server front panel display will be dark green in colour, showing a 'Server Locked' message:



- Viewed in [Stack Overview](#), a locked server will display a blue 'Read Only' status in its Health column:

10.100.100.38   10.100.111.38	2	Leader	Healthy	
10.100.100.43   10.100.111.43	3	Follower	Healthy	Read Only
10.100.100.35   10.100.111.35	3	Follower	Healthy	Read Only

## Appendix I: Express Mode, Creating Shows Programmatically

---

Delta shows can be constructed, managed and run using external control commands. There is an application, StackExpress, that writes these Express Mode shows for you via a simple web browser interface.

However, the JSON files created in this way can also be programmed manually as scripts. These can be loaded into Delta, again using external controls, and with Delta running in Express Mode, the programmed show will run.

### Configuring Delta for Express Mode

---

Express Mode in Delta can be enabled in one of three ways.

#### External Control

The quickest method to enable/disable Express Mode is to call the external command: **SETEXPRESSMODE ENABLED=[Y/N]**.

#### Registry Edit

Alternatively it can be done through the Registry Editor by navigating to: **HKEY\_LOCAL\_MACHINE\SOFTWARE\7thSense\Delta**. From there locate **ExpressMode** and change the value to 1.

#### On Load

If neither of these methods is used, Express Mode will be enabled automatically when a media json config file is loaded using the **LOADMEDIAJSON** external control command.

## The JSON Structure

---

### Top Level Structure

```
1  {
2    "tl-1": {
3  >   "Config": { ...
14   },
15 >   "Clips": [ ...
85   ],
86   "timeline": 1
87   },
88 >   "tl-2": { ...
127  },
128  "tlToEdit": 1
129 }
```

At this level, there should only be timeline objects and the `"tlToEdit"` field.

Add a timeline object in the format of `"tl-x": {}` for every timeline you want to create.

The `"tlToEdit"` field specifies which timeline object from the JSON to load into the show.

### Config Structure

```
"Config": {
  "ClipCount": 3,
  "StartFrame": 0,
  "Timeline": 1,
  "KeepDisplayConfig": 0,
  "Layer": 1,
  "Channel": 1,
  "Merge": 0,
  "ClearExpressLayer": 0,
  "Dirty": 0,
  "JSONFileVersion": 1
},
```

#### ClipCount

Should match the number of clips in the `"Clips"` array.

#### StartFrame

The frame on which to start placing clips.

**Timeline**

Should match the number of the outer object, e.g. for tl-1 this must be 1.

**KeepDisplayConfig**

Set to 1 to keep the current display config, set to 0 to overwrite the current display config.

**Layer**

The layer on the timeline on which to place the clips.

**Channel**

(Not used.)

**Merge**

Set to 1 if you have a base file you want to merge the express layer into, rather than completely overwriting the existing file.

**ClearExpressLayer**

(If "Merge" is set to 1)

0: Load in clips from this file without clearing the current Express layer.

1: Clear the current express layer before loading in the new clips.

**Dirty**

Set to 1 if "Merge" is 1 and the clips in this file have changed since Delta last processed this file, otherwise set to 0.

**JSONFileVersion**

Should always be 1.

## Clips Structure

```
"Clips": [  
  {  
    "ID": 1000,  
    "Type": "Movie",  
    "MediaType": "tga",  
    "Length": 100,  
    "Name": "7thFlyAnimationHD",  
    "InPoint": 0,  
    "OutPoint": "end",  
    "CrossFade": 0,  
    "PlayMode": "playOnce",  
    "PlayModeDetails": 1,  
    "Size": "FullScreen",  
    "FadeMode": "None",  
    "FadeModeDetails": "both",  
    "FadeModeLength": 30,  
    "PlaySpeed": 1,  
    "DisableCodecAudio": 0,  
    "MatchAudio": 1,  
    "EndTransition": "Play",  
    "StopType": "First",  
    "Actions": [],  
    "LengthMode": "length"  
  },  
]
```

### ID

Used to name the clip on the timeline. Will be formatted as "Clip\_{ID} : {Name}". Should be sequential. Avoid clashes with other clips.

### Type

The type of resource. Can be "Movie", "Image", or "Capture".

### MediaType

Needs to match the file extension of the media; e.g. "tga", "mp4", "jpg". If "Type" is "Capture" then leave this blank ("").

### Length

The length in frames of the resource. For movie resources, if this does not match the number of frames in the movie, it will be trimmed or looped to meet this value.

### Name

The name of the resource on disk (excluding the extension). If on a movie resource, looks in "C:\Movies", if on an image resource, looks in "C:\Images", if on a capture resource this should be the name of the capture device, e.g. "Integrated Webcam :ID 10000".

**InPoint**

Trim a movie resource to start from a specified frame. Must be between 0 and the total number of frames in the movie and always less than Outpoint.

**OutPoint**

Trim a movie resource to end on a specified frame. Must be between 0 and the total number of frames in the movie and always greater than InPoint. Set to "end" to not trim the movie.

(Ensure "LengthMode" is set to the correct value when using "Length" vs "InPoint"/"OutPoint".

**CrossFade**

Leave as 0.

**PlayMode**

"PlayOnce": This clip will play once then move on to the next clip.

"PlayCount": This clip will play the amount of times specified in "PlayModeDetails" before moving on to the next clip.

**PlayModeDetails**

The amount of times to loop this clip (only if "PlayMode" is "PlayCount").

**Size**

Leave as "FullScreen".

**FadeMode**

"None": No transition between clips.

"Transparent": A fade in/out is applied to the clip with a length specified in "FadeModeLength" (seconds).

**FadeModeDetails**

Always "both".

**FadeModeLength**

Time in seconds to fade in/out of resource (if "FadeMode" is "Transparent").

**PlaySpeed**

Sets the play speed of a movie resource. Doesn't affect the length of the resource on the timeline.

**DisableCodecAudio**

Only used for Codec Movie resources. If set to 1 then the movie's audio will be disabled.

**MatchAudio**

Search for any audio files which contain the same resource name as the movie and add them to the timeline at the same frame as the movie and 4 layers lower.

### EndTransition

“Play” – continue playing after this clip.

“Stop” – stop playback after this clip.

### StopType

“EndTransition” must be “Stop” for this to have any effect.

“Last”: Stop at the end of this clip

“First”: Stop at the beginning of the next clip

### Actions

Place Delta sequences on the timeline

```
"Actions": [  
  {  
    "id": "1",  
    "frame": 20,  
    "tlFrame": 20,  
    "action": "SE_test-sequence",  
    "valid": true  
  }  
],
```

<b>id</b>	Sequential action ID
<b>frame</b>	The RESOURCE frame number to place the sequence on
<b>tlFrame</b>	The TIMELINE frame number to place the sequence on
<b>action</b>	The name of the sequence to add to the timeline
<b>valid</b>	Set to “true”

### LengthMode

“length” – Use the “Length” field to determine the length of the resource.

“in/out” – Use the “InPoint” and “OutPoint” fields to determine the length of the resource.

## Ingesting into Delta

---

Once the JSON file has been created, copy it into **C:\7thsense\JSON** name it **media.json**.

To trigger Delta to generate the timeline, use the **LOADMEDIAJSON** external control.



This takes one argument, “**tl=x**” where x is the number of the timeline you want to populate. This does not have to match the “**tlToEdit**” field in the top level of the JSON file. “**tlToEdit**” specifies which of the timeline objects to process from the JSON file, whereas the **tl** argument to the **LOADMEDIAJSON** command specifies which timeline within Delta onto which to load content.

If you wish to populate multiple timelines, then it is recommended to store all the timelines in **media.json** (as tl-1, tl-2, etc.) and load them one at a time by updating “**tlToEdit**” to point to the desired timeline, and calling **LOADMEDIAJSON TL=X** to upload it to the correct timeline in Delta.



## Document Information

## Document Information

---

Date	Document edition	Software version	Revision Details	Author/Editor
March 2020	1	2.7	New release	Andie Davidson
July 2020	2	2.7 build 5	Revised server terminology	Andie Davidson
August 2021	3	2.7 build 6 Beta	Rebranded product, system performance updates, new scaling options, selectable Art-Net / DMX ports, resource pool expand button. Express Mode explained, new DeltaPreview web page location.	Andie Davidson
June 2022	4	2.7.8	DPX 8- and -10-bit RGBA 4:4:4 media carving. SSH communications HDR image and movie formats.	Andie Davidson

### Windows Registry Settings

This document is supplied for informational purposes only. Any modification to Windows Registry values that are not exposed via the DeltaServer or DeltaGUI application interfaces – or otherwise advised by 7thSense personnel – may result in performance degradation and/or complete instability of the products. Any attempt to engage 7thSense for support in troubleshooting may result in the reversal of all Registry settings to the factory default or last known good 7thSense-approved configuration. **The customer assumes all risk when manually editing any Windows Registry values on any 7thSense product.**

•

- .obj files 259
- .vto files 259

## 3

### 3D

- active stereo configuration 137
- anaglyph stereo (3D) 135
- blue line mode (3D) 135, 137
- eye separation (3D) 135, 137
- passive stereo configuration 135
- wizard 135, 137

- 3D stereo show wizard
  - audio offset 140

## A

- align timeline media 282
- alignment aids 134
- animation
  - movement 349
  - rotation 349
  - transform 350

### Art-Net

- create input resources 382
- create output resources 380
- examples 382
- input 382
- input controls 386
- output 380
- output controls 386
- pool resources 386
- recording 426
- timeline resources 386

- Art-Net and DMX layers 343

- Art-Net and DMX settings 123

- Art-Net controls 39

- Art-Net output, input 340

- Art-Net resources 379

- Art-Net, DMX controls 48

### audio

- audio levels 312
- configure LTC output track 120
- configure playback devices 120
- equalisation 429
- guess mapping preset 116
- hi pass/low pass filter 429
- levels 121, 429
- looping 312

- mapping presets 121
- mixing 312
- seamless joins 312
- supported formats 45
- surround sound 45

- audio mapping (custom) 121

- AudioMapper 121

- Auto Align licence 208

- auto alignment 95

### autoalignment

- camera 206
- configure Delta 208
- licensing 206
- preparation 206
- pre-warped media 181
- refresh Delta AutoAlign 216
- use calibration as primary 216
- using MPCDI data 217
- warp and blend 208

- AV assemblies 387, 393

## B

- background layer 343
- blends 39, 150
- blocked server groups 102

## C

- canvas colour 128
- canvas position for image 344, 345
- canvas types 127
- capture 39
- carving media 419
- cloning resource parameters 282
- colour balancing 153
- colour balancing and convergence 47
- colour balancing projectors 375
- colour convergence 153
- colour correction 39
- colour grading 375
- colour LUTs 375
- command line switches 455
- communication configuration 102
- composition mode
  - channels and viewports 188
  - DeltaGUI 188
  - IntelligentSource 191
  - layout 183
  - media optimisation 183
  - multiple displays 183
  - principle 183

- container resources 387
- containers, AV 393
- containers, playlist / AV assembly 49
- control PC 13
- controls placeholder 332
- copy timeline between servers 57
- cut timeline media 282

## D

- debug a sequence 362
- definitions of display terms 127
- Delta Media Server 12
- Delta Web Service 12, 414
- DeltaAudio 12
- DeltaGUI 12
- DeltaGUI connection
  - troubleshooting 456
- DeltaGUI functions 52
- DeltaGUI interface, explained 61
- DeltaGUI main menu 61
- DeltaGUI startup group 53
- DeltaMonitor 12
- DeltaOffline 432
  - installation 433
  - limitations 435
  - running 435
  - watermark 435
- DeltaServer 12, 26
  - close DeltaGUI 28
  - licence update 28
  - main menu 28
  - preferences 28
- DeltaServer user interface 27
- diagnostic logs 459
- disk drive configuration (images, audio, movies) 97
- display configuration elements 127
- display configuration files 159
- display controls 89
- Display menu (DeltaGUI) 61
- display mode 127
- display movie timecode 334
- display playback information 125, 415
- display timecode 334
- display, identify 89
- DMX
  - examples 382
  - input 382
  - input controls 386
  - output 380
  - output controls 386

- DMX output, input 340
- DMX resources 379
- Document information 476
- dome display configuration 193
- dome mode
  - alignment 193
  - canvas definition 193
  - channel view 195
  - dimensions 193
  - display grid 195
  - interactive view 195
  - layering 204
  - panoramic media 204
  - partial domes 204
  - playback window 195
  - preview 195
  - projector position 200
  - resource defaults 116
  - resource mapping types 204
  - save viewpoints 195
  - sizing channels 200

## E

- edge blending 150
- editing a mesh .obj 259
- effects (timeline)
  - dynamic audio 396
  - dynamic keying 396
  - fade 396
  - file locations 45
  - formats 45
  - timeline alpha 396
  - transform animator 396
  - transparency 396
- encrypted movies 61
- encrypting movies 43
- ethernet configuration 102
- export geometry 146
- express mode 467
  - JSON structure 468
- express mode, set 467
- EXR files (warp) 181
- external control 439
  - return codes 441
  - troubleshooting 444
- external controls 409
- eyepoint
  - dome 193

**F**

- fade 39
- fade between timelines 61
- fading between layers 81, 83
- file location
  - Art-Net 48
  - audio 45
  - blends 45
  - containers 49
  - effects 49
  - flat colour 47
  - images 44
  - movies 40
  - sequences 50
  - serial events 46
  - splines 48
  - warp geometry 46
- find resources 298
- flat plane mode
  - alignment 170
  - Auto Alignment 170
  - blending 170, 179
  - canvas/panel rotation 161
  - channel defaults 169
  - channel joins 165
  - channel overlap 175
  - channel resizing, dynamic 161
  - channel rotation 175
  - channel setup 172
  - channels 161
  - colour correction 179
  - configuration procedure 170
  - defaults wizard 172
  - display configuration 161
  - display configuration files 180
  - preview window setup 167
  - resource defaults 116
  - viewports: output channels 167
  - warping 170, 175
- frustum (dome) mode 193
- full screen playback toggle 27

**G**

- genlock 449
- genlock, LTC chasing 99
- geometry 353
  - background layer 142
- global variables 365, 382
- glossary 19

- glossary, Delta 19
- GoTo timeline control 332
- graph line colours 33
- group flashes red 53
- grouping servers 13

**H**

- help and guides
  - eBook 10
  - online 10
  - PDF 10
- Help menu (DeltaGUI) 61
- hold on last frame 282

**I**

- identify display channels 89
- image scaling 344
- images
  - supported formats 44
- import resources 300
- ingest resources 300
- install Delta - what is included 17
- installing Delta 17
- IntelligentSource 326
- interactive positioning of resources 345
- interactivity 303
  - enabled in resources 114
  - gesture, mouse enabled 114
  - kiosk application 114

**L**

- layer transitions 83
- layers area 81
- layers explained 83
- layout view 345
- LCTimeline (logic control) 382
- leader-follower 57
- leader-follower control 13
- LED displays 183
- licensing DeltaServer
  - 7thSense 445
  - expiry 445
  - integrator/reseller 445
  - updating 445
- list markers 285
- load default show 95
- log files 459
- loop timeline media 282
- LTC 449

## M

- macros 354
- markers
  - snap to marker 285
- media layers 343
- media resource animation 349
- media resources 79
- media resources supported 39
- menus, DeltaGUI
  - main 61
  - servers 69
  - workspaes 68
- merge autoalignment 95
- merge common resources 95
- merge permanent display config 95
- mesh mode
  - 2D/3D view (calibration) 235
  - 3D calibration 235
  - active 3D workflow 255
  - apply lens distortion 235
  - blending 248
  - canvas 228
  - channel beam controls 228
  - clipping planes 259
  - configuration 221
  - DeltaGUI 228
  - editing a mesh .obj 259
  - editing points 235
  - explained 221
  - eyepoint 228
  - eyepoint parameters 225, 227
  - how it works 225
  - lens modes 235
  - linked vertex selection 259
  - manipulating the mesh view 235
  - media 221
  - mesh editor 259
  - mesh not showing on playback 248
  - movement nodes 267
  - node movement size 259
  - node selection size 259
  - node size 259
  - projection (flat) mode 221
  - projector positions 228
  - setup sequence 226
  - textured (UV) mode 221
  - textured mode 252
  - troubleshooting 248
  - using multiple meshes 253
  - warp, distort or edit? 248
  - warping a mesh 245
- mesh models 221
- MiniDump log files 459
- miscellaneous settings
  - autoplay movies 113
  - cross-fade timelines 113
  - sync mesh files to DeltaGUI 113
  - video capture on pause 113
- mismatched software version 53
- morph 353
- motion effects 350
- motion paths (splines) 48, 155
- motion tracking 269
- movies
  - encrypted 274
  - encrypting 43
  - formats, quality, requirements 43
  - framerate compensation 309
  - hold on last frame 309
  - looping 309
  - missing frames 274
  - supported formats 40
- MPCDI file sets, location 217

## N

- NatNet streaming 269
- NDI capture 322
- NDI Preview
  - enable 112
- NDI, enable 414
- non-seamless looping 290
- Notch effects 402

## O

- online help 438
- optical tracking 269
- OptiTrack Motive 269
- output channel modes 128
- output colour space 128
- output mode 128
- output setup 128

## P

- path defaults (other resources) 118
- path defaults (show, recording, mesh) 97
- permanent geometry 159
- pixel shift 128
- placeholders



- placeholders
    - clone properties 281
    - controls 278
    - media 278,281
    - replace media 281
  - playback controls 77
  - playback problems 458
  - playback window 61
    - allow global interactivity 114
    - audio VU meter 33
    - display movie timecode 334
    - display timecode 334
    - graph 33
    - information 33
    - movie timecode 33
    - quick keys 33
    - statistics 33
    - timecode 33
  - playlist
    - child resource overrides 390
    - overrides, global 391
  - playlists 49
  - playlists container 387
  - point distortion grid 146
  - preset resources 297
  - preview
    - configure 415
    - connect 415
    - external controls 415
    - from DeltaGUI 415
    - from Stack web interface 415
    - web browser 414
  - preview window settings 112
  - pre-warped media 181
  - projection mapping 221
  - projector colour balance 375
  - Protecting the C:\ drive 464
- ## R
- RAID7th disk array 97
  - recording 424
    - Art-Net 426
  - recording from preview 424
  - recording from timelines 419
  - recording shows
    - paths and variables 419
  - render modes 128
  - replacing timeline resources 282
  - reserve (timeline) mode 61
  - reserve timeline 84
  - reset distortion 146
  - resource default settings 116
  - resource editor
    - Art-Net and DMX 340
    - audio 304
    - audio attributes 312
    - canvas position 344
    - capture 304
    - chroma and luma 338
    - colour controls 340
    - controls placeholder 332
    - events 304
    - framerate compensation 312
    - general 303
    - GoTo control 332
    - looping 312
    - markers 304
    - movie attributes 309
    - movie timecode 334
    - movies and images 304
    - text 334
    - timecode 334
    - timeline settings 304
    - video capture 314
  - resource folders 79
  - resource layout on canvas 345
  - resource pool width 79
  - resource properties 298
  - restoring a mesh .obj 259
  - reverse playback 77
- ## S
- save (shows) 61
  - save all (shows) 61
  - save configured resource 297
  - save locally 61
  - Scalable Display Manager
    - autoalignment 209
    - boundary 209
    - calibration 209
    - cameras 209
    - display clients 209
    - eye point 209
    - file locations 209
    - import to Delta 209
    - orientation 209
    - perspective 209
    - projectors 209
    - screen shape 209
  - SDI configuration 447

- seamless audio joins 290
  - seamless looping 290,293
  - search resources 298
  - select server for DeltaGUI 69
  - sequence blocks 354
  - sequence editor 354
    - active sequences 370
    - assign buttons 363
    - code syntax 368
    - pages 363
    - running 363
    - variables 365
  - sequence panel
    - assign buttons 371
  - sequences 354
    - debug 362
    - run 363
    - write or edit 358
  - serial events 373
    - Telnet 46,375
  - serial ports 102
  - server connections 53
  - server group (assign) 94
  - server group mode (output) 128
  - server grouping 57
  - server groups 13,53
  - server information 105
  - server messages 76
  - server status, DeltaServer 27
  - server type (assign) 94
  - shader effects 39,49,399
    - bit-depth shader 401
    - degradation shader 401
    - fade 397
    - frag files 397
    - Notch 397
    - transparency 397
    - vert files 397
    - xml files 397
  - shortcut keys, DeltaGUI and DeltaServer 453
  - show mode
    - defaults on load 117
    - streaming video 117
  - show-building 343
  - Show-mode 61
  - slideshows
    - creating 405
    - timing 405
  - slow DeltaGUI PC 71
  - SMPTE device 99
  - snap to grid 345
  - splines 39,48
    - configuration 155
    - controls 155
    - snap to grid 155
    - timing 377
  - split timeline media 282
  - Spout capture 316
  - SSH 102
  - ST2110 128
  - ST maps 181
  - startup preferences 95
  - startup sequence 95
  - stereo (3D)
    - active 137
    - passive 135
  - stream capture 325
  - surface geometry 144
  - switches
    - beams 272
    - warp 272
  - system architecture 12
  - system logging 94
  - system logs, DeltaServer 459
  - system preferences 94
- ## T
- TCD 293
  - TCP connection (server) 102
  - TCP connections (client) 91
  - templating a timeline 282
  - terms and definitions 19
  - test patterns 134
  - text 39
  - timeline
    - add resources 274
    - aligning media 282
    - arranging resources 278
    - Composite mode 86
    - configure properties 302
    - control lines 285
    - controls 77,276
    - cross-fade 84
    - cutting media 282
    - delete media 295
    - dialog 86
    - disable layer 295
    - disable resource 295
    - disable visual resources 86
    - duration of resources 276
    - face 86

- timeline
    - geometry properties 282
    - Global Z mode 86
    - group selection of resources 279
    - layer properties 282
    - length 99
    - lock resource 295
    - looping media 282
    - markers 285
    - media placeholders 281
    - mode 86
    - movie properties 282
    - multiple 84
    - naming 84
    - naming and selection 69
    - normal mode 86
    - opacity 86
    - outline media 296
    - playback controls 86
    - positioning resources 276
    - replacing resources 278
    - reserve 84
    - reserve timeline, assign 86
    - resource editor 302
    - resource properties 282
    - splitting, cutting, concatenating media 282
    - summary 299
  - timeline controls
    - DeltaServer 28
    - GoTo 332
  - timeline resource properties 81
  - timing
    - Adrielec 451
    - BlackMagic 449
    - BlueFish SDI 449
    - configuration 99
    - control area 78
    - control network connection 99
    - external LTC 451
    - framerates 99
    - mode 99
    - MTC input 451
    - RS422 devices 449
    - RS422 transport controls 451
  - timing controls 39
  - timing controls distribution 293
  - timing group 13
  - toolbars and buttons 89
  - transform animation 350
    - absolute 350
    - relative 351
  - speed 352
  - transition effects 399
  - transitions 39
  - transparency 39
  - troubleshooting 456
    - mesh mode 248
    - mesh not showing in playback 248
- ## U
- UDP connection (server) 102
  - uninstalling Delta 17
  - user interface
    - active timeline indicators 109
    - autosave 109
    - colours 108
    - control lines 71
    - decluttering 71
    - DeltaGUI password 109
    - DeltaGUI update options 71
    - fade, transparency 109
    - file modified warnings 110
    - graphics 107
    - grid snap 107
    - highlights 71
    - intelligent resources 109
    - juddering GUI when playing 71
    - layer preferences 71
    - layer sizes 107
    - resource window 109
    - snap options 71
    - snap to grid/resources 107
    - tooltips 71,107
    - update frequency 107
  - user stats settings (playback window user information) 125
  - UV mapped media 221
- ## V
- variables 365
  - version (Delta) 14,53
  - version (DeltaGUI) 61
  - video capture
    - deinterlace 314
    - device IDs 314
    - freeze group 314
    - groups 328
    - Spout 316
    - web resource 319
  - View menu (DeltaGUI) 61
  - view server list 57

VIOSO 217  
VNC password 94

## W

warp  
  background layer 142  
  colour convergence 144  
  controls 144  
  distortion 353  
  grid 144  
  point distortion 146  
  surface 144, 353  
  timeline 353  
  timeline (channel) 143  
web resource  
  JavaScript events 319  
  transparency 319  
WebRTC  
  enable 112  
WebRTC, enable 414  
Windows 10 UWF 464  
Windows event logs 459  
wizard  
  slideshow 405  
Wizards 61  
wobulation projectors 128

## X

XDL files 159







E: [info@7thsense.one](mailto:info@7thsense.one)  
W: [7thsense.one](http://7thsense.one)

7thSense Design Ltd  
2 The Courtyard, Shoreham Road  
Upper Beeding  
Steyning  
West Sussex  
BN44 3TN  
UK

T: +44 (0) 1903 812299

7thSense LLC  
4207 Vineland Rd  
Suite M1  
Orlando, FL 32811  
USA

T: +1 407 505 5200